

12211

93-97 VOLVO 850, 98-00 S70, 98-00 V70, 98-04 C70, 98 V70R

7/18/2012

GROSS LOAD CAPACITY WHEN USED AS A WEIGHT CARRYING HITCH: 3500 LBS. TRAILER WEIGHT & 300 LBS. TONGUE WEIGHT.

DO NOT EXCEED VEHICLE MANUFACTURER'S RECOMMENDED TOWING CAPACITY.

WARNING: ALL NON-TRAILER LOADS APPLIED TO THIS PRODUCT MUST BE SUPPORTED BY AUXILIARY STABILIZING STRAPS.

** FAILURE TO PROPERLY SUPPORT NON-TRAILER LOADS WILL VOID PRODUCT WARRANTY**

HAVING INSTALLATION QUESTIONS? CALL TECHNICAL SUPPORT AT 1-800-798-0813

Parts List			
ITEM	QTY	PART NUMBER	DESCRIPTION
1	2	1/2-13	HANDLE NUT
2	2	1/2-13 x 1 3/4	HEX BOLT
3	3	1/2"	LOCK WASHER
4	1	1/2-13 x 1 3/4	CARRIAGE BOLT
5	1	1/2-13	HEX NUT
6	1	CM-SP40	.188 x 1.00 x 3.00" SQUARE HOLE SPACER

RUBBER ISOLATOR REMOVAL DIAGRAM

This technique can be used if and Exhaust Hanger Removal Pliers is not available.

Using a 5/8" open end wrench, slide the wrench up to the rubber isolator, cradling the hanger rod as shown. Next place the flat edge of a pry bar between the wrench and the hanger stop or hanger rod. Then simply rotate the pry bar toward the wrench to remove the rubber isolator.

Note: Using a spray lubricant or soapy water on the hanger rod and the rubber isolator helps removal.

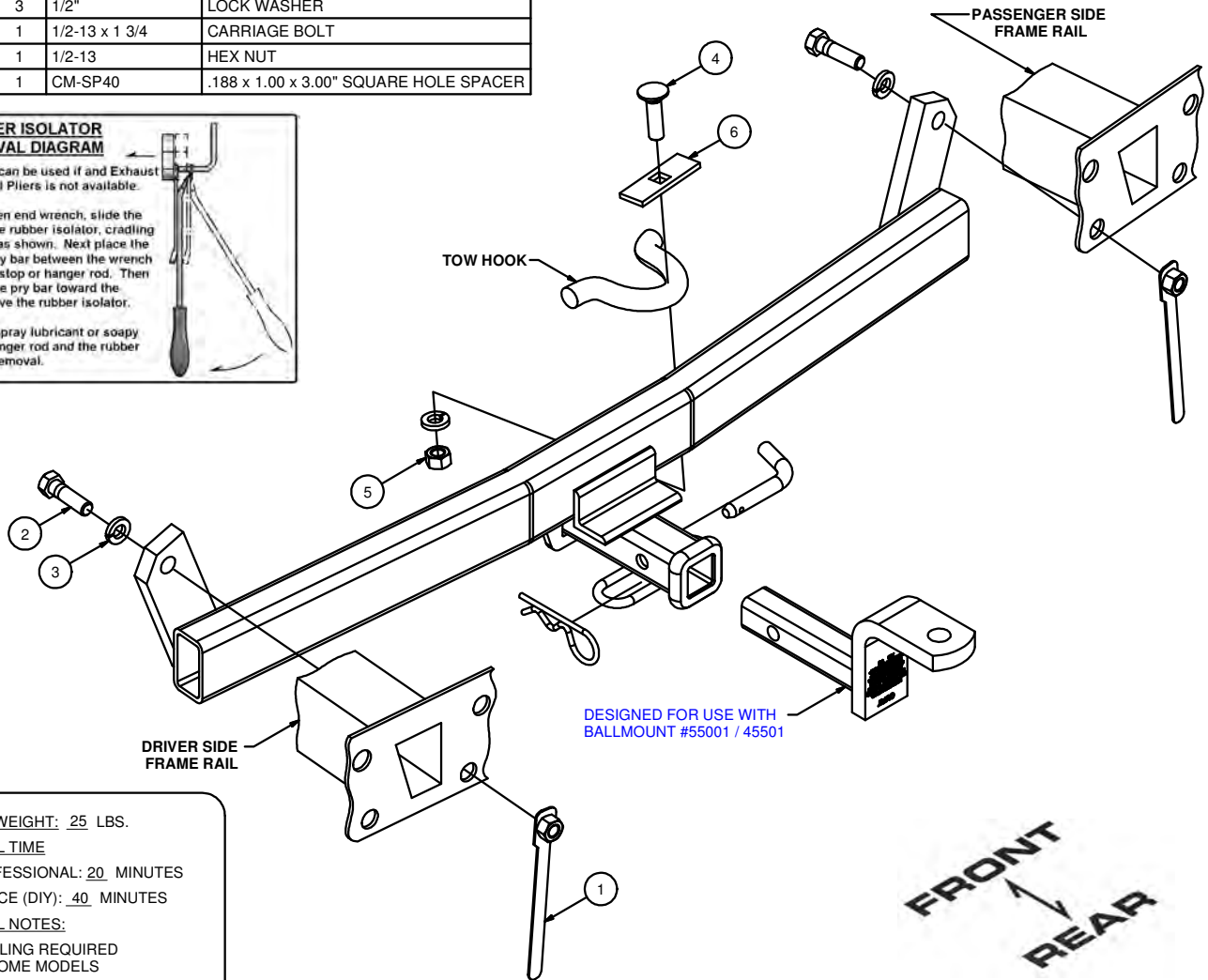

HITCH WEIGHT: 25 LBS.
 INSTALL TIME
 PROFESSIONAL: 20 MINUTES
 NOVICE (DIY): 40 MINUTES
 INSTALL NOTES:
 -DRILLING REQUIRED ON SOME MODELS

INSTALLATION STEPS

- 1) Temporarily lower exhaust at rear of car by unhooking hangers. Locate chassis end brackets under rear of car where bumper attaches. Temporarily lift hitch into position as shown. Some sedans will require drilling through these bottom inboard holes into bumper bracket and bumper for end clearance of bolts.
- 2) Handle nuts must fit between rear side of chassis end brackets and bumper. On certain models it may be necessary to loosen rear bumper from chassis temporarily to place handle nuts.
- 3) Raise hitch into position and install fasteners as shown.
- 4) Torque all hardware to 110 lb.-ft.

PERIODICALLY CHECK THIS RECEIVER HITCH TO ENSURE THAT ALL FASTENERS ARE TIGHT AND THAT ALL STRUCTURAL COMPONENTS ARE SOUND.

Curt Manufacturing Inc., warrants this product to be free of defects in material and/or workmanship at the time of retail purchase by the original purchaser. If the product is found to be defective, Curt Manufacturing Inc., may repair or replace the product, at their option, when the product is returned, prepaid, with proof of purchase. Alteration to, misuse of, or improper installation of this product voids the warranty. Curt Manufacturing Inc.'s liability is limited to repair or replacement of products found to be defective, and specifically excludes liability for incidental or consequential loss or damage.