

12247

NISSAN ROGUE S & SL, 2WD & AWD

9/28/2012

GROSS LOAD CAPACITY WHEN USED AS A WEIGHT CARRYING HITCH: 3500 LBS. TRAILER WEIGHT & 350 LBS. TONGUE WEIGHT.
 DO NOT EXCEED VEHICLE MANUFACTURER'S RECOMMENDED TOWING CAPACITY.

Parts List

ITEM	QTY	PART NUMBER	DESCRIPTION
1	6	M12-1.25 x 35mm	HEX BOLT
2	6	1/2"	CONICAL TOOTHED WASHER

TOOLS REQUIRED

3/8" DRIVE RACHET
3/8" DRIVE 8" EXTENTION
3/8" DRIVE TORQUE WRENCH
8mm - 3/8" DRIVE SOCKET
18mm - 3/8" DRIVE SOCKET
19mm - 3/8" DRIVE SOCKET

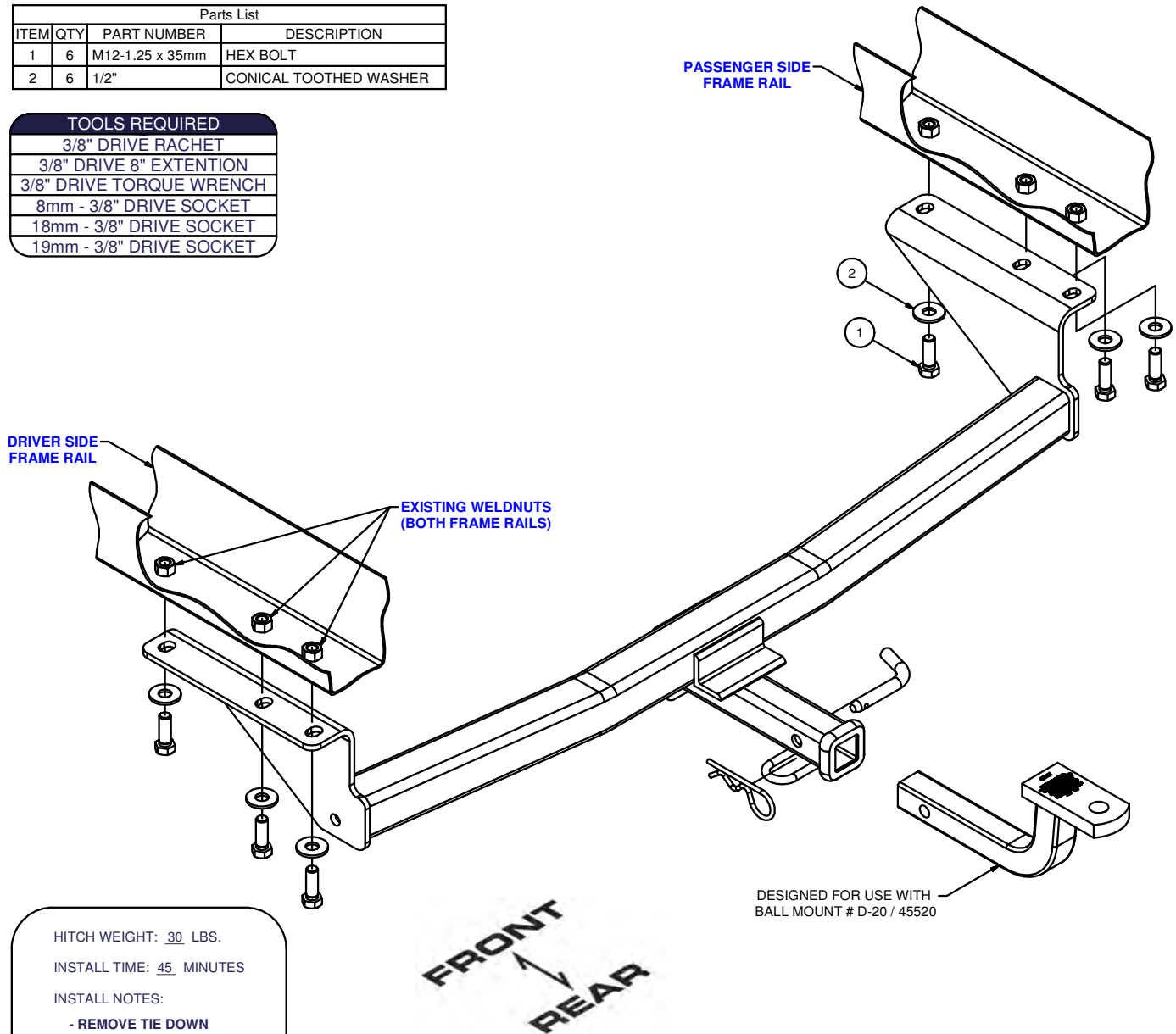
HITCH WEIGHT: 30 LBS.INSTALL TIME: 45 MINUTES

INSTALL NOTES:

- REMOVE TIE DOWN
- LOWER EXHAUST
- NO DRILLING

INSTALLATION STEPS

- 1) Remove tow hook from the passenger side frame rail (5 bolts) and return to customer.
- 2) Remove small screw from heat shield on the passenger side frame rail and return to customer.
- 3) Lower exhaust for ease of installation.
- 4) Raise hitch into position and secure with hex bolts and conical washers as shown in the diagram above.
- 5) Torque all 12mm fasteners to 79 LB-FT.
- 6) Re-install exhaust removed in step 2.

PERIODICALLY CHECK THIS RECEIVER HITCH TO ENSURE THAT ALL FASTENERS ARE TIGHT AND THAT ALL STRUCTURAL COMPONENTS ARE SOUND.

Curt Manufacturing Inc., warrants this product to be free of defects in material and/or workmanship at the time of retail purchase by the original purchaser. If the product is found to be defective, Curt Manufacturing Inc., may repair or replace the product, at their option, when the product is returned, prepaid, with proof of purchase. Alteration to, misuse of, or improper installation of this product voids the warranty. Curt Manufacturing Inc.'s liability is limited to repair or replacement of products found to be defective, and specifically excludes liability for incidental or consequential loss or damage.