



13005 INSTALLATION INSTRUCTIONS



Safety glasses should be worn at all times while installing this product.

YEARS: 2010

MAKE: KIA

MODEL: BORREGO

STYLE: SUV

WARNING: NEVER EXCEED YOUR VEHICLE MANUFACTURER'S RECOMMENDED TOWING CAPACITY

WEIGHT CARRYING:
TRAILER WEIGHT: 5,000 LBS.
TONGUE WEIGHT: 500 LBS.

WEIGHT DISTRIBUTION:
TRAILER WEIGHT: 7,500 LBS.
TONGUE WEIGHT: 750 LBS.

INSTALLATION TIME: 30 MIN.

THE INSTALL TIME LISTED IS FOR PROFESSIONAL INSTALLERS. IF YOU ARE HESITANT TO UNDERTAKE THIS TASK ON YOUR OWN, CONTACT AN AUTHORIZED CURT INSTALLER FOR ADDITIONAL ASSISTANCE.

INSTALLATION TIPS:





1. BEFORE YOU BEGIN INSTALLATION, READ ALL INSTRUCTIONS THOROUGHLY.
2. TO EASE INSTALLATION, 2 PEOPLE MAY BE REQUIRED.
3. USING PROPER TOOLS WILL GREATLY IMPROVE THE QUALITY OF THE INSTALL AND REDUCE THE TIME REQUIRED.
4. NEED HELP OR HAVE SOME QUESTIONS? CALL TECHNICAL SUPPORT AT 800.798.0813

VEHICLE PHOTO:



REPRESENTATIVE PHOTO

INSTALLATION REQUIRES:

 RATCHET	 SOCKET	 TORQUE WRENCH
 SAFETY GLASSES		

LEVEL OF DIFFICULTY: MODERATE

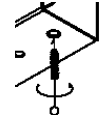
EASY	MODERATE	HARD
	NO DRILLING REQUIRED	
	WELDNUT CLEANING MAY BE REQUIRED	

HITCH ILLUSTRATION:

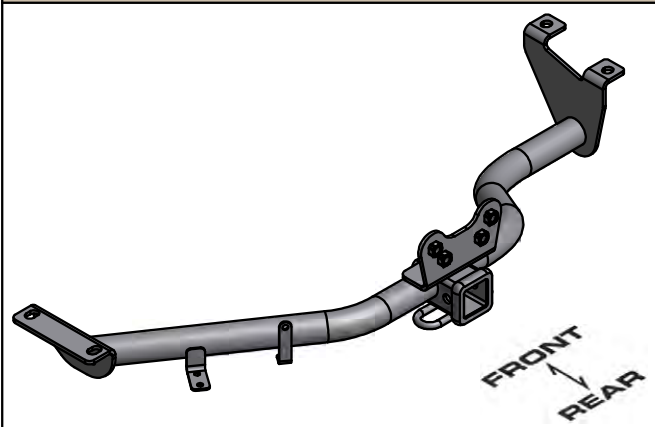

MAKE SURE YOUR HITCH MATCHES

PERIODICALLY CHECK THIS RECEIVER HITCH TO ENSURE ALL FASTENERS ARE TIGHT AND ALL STRUCTURAL COMPONENTS ARE SOUND

CURT Manufacturing Inc. warrants this product to be free of defects in material and/or workmanship at the time of retail purchase by the original purchaser. If the product is found to be defective, Curt Manufacturing Inc. may repair or replace the product at their option, when the product is returned, prepaid, with proof of purchase. Alteration to, misuse of, or improper installation of this product voids the warranty. Curt Manufacturing Inc.'s liability is limited to repair or replacement of products found to be defective, and specifically excludes liability for incidental or consequential loss or damage.

For more information log onto www.curtmfg.com, & for helpful towing tips log onto www.hitchinfo.com

INSTALLATION WALKTHROUGH:

Parts List			
ITEM	QTY	PART NUMBER	DESCRIPTION
1	4	1/2-13 x 3	HEX BOLT
2	4	1/2"	LOCK WASHER
3	4	M12 - 1.25 x 25 HEX	HEX BOLT
4	4	1/2"	CONICAL TOOTHED WASHER
5	3	HexCapScrewInch	
6	3	5/16"	WASHER
7	3	5/16-18 HEX NUT	5/16-18 HEX NUT
8	4	CM-116415-CT	CABLE TIE 11/64 X 15" 50# UV BLACK

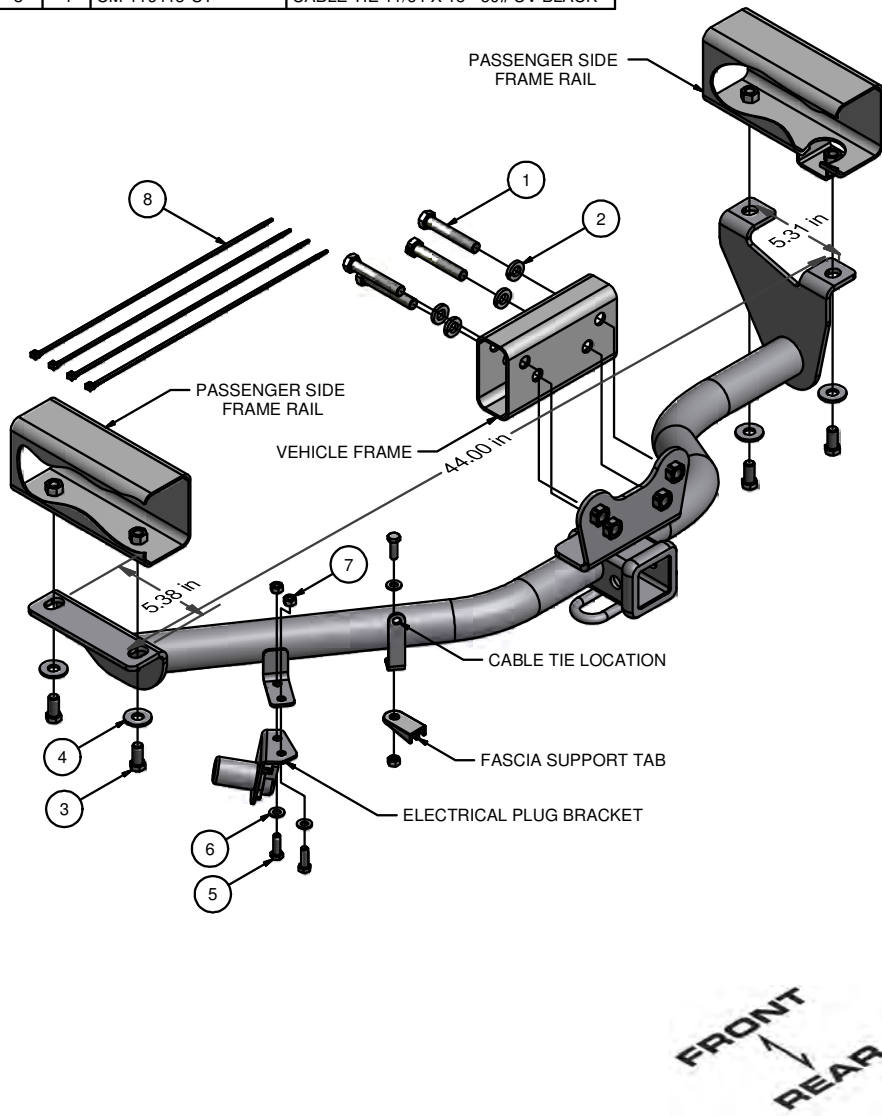

1. Lower spare tire.

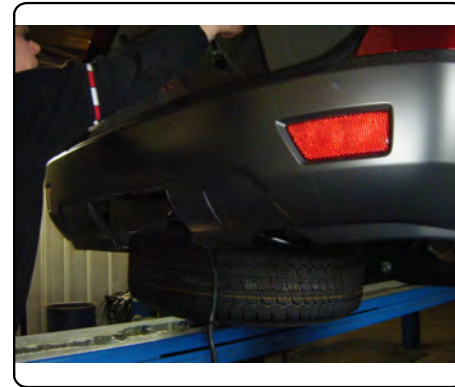

2. Raise hitch into position and attach center of hitch to frame using (4) 1/2-13 x 3 bolts. (Finger tight)

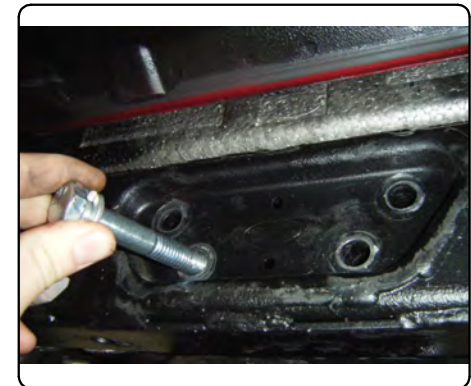
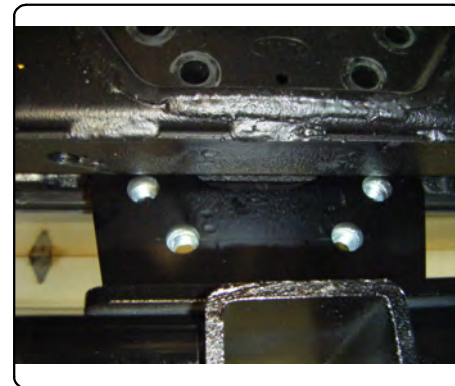

INSTALLATION WALKTHROUGH:

3. Attach hitch to existing weldnuts on driver and passenger side frame rails using M12 hardware. (Finger tight)

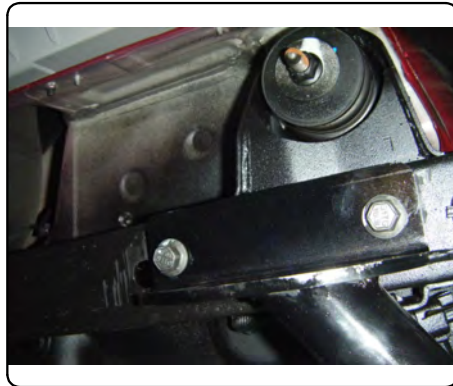

4. Torque all 1/2 in hardware to 110 ft-lbs, M12 hardware to 86 ft-lbs, and 5/16 to 24 ft-lbs.



5. Attach hitch to fascia support tab and electrical plug bracket using 5/16 in hardware.

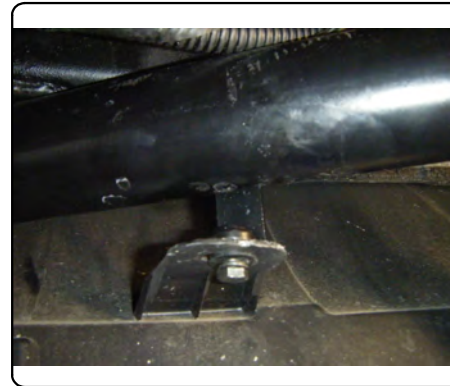

6. Use cable ties to secure electrical wiring and raise spare tire back into position.
Installation is complete.



13005

KIA BORREGO

11/30/2012

GROSS LOAD CAPACITY WHEN USED AS A WEIGHT CARRYING HITCH: 5,000 LBS. TRAILER WEIGHT & 500 LBS. TONGUE WEIGHT.
GROSS LOAD CAPACITY WHEN USED AS A WEIGHT DISTRIBUTION HITCH: 7,500 LBS. TRAILER WEIGHT & 750 LBS. TONGUE WEIGHT

***** DO NOT EXCEED VEHICLE MANUFACTURER'S RECOMMENDED TOWING CAPACITY. *****

HAVING INSTALLATION QUESTIONS? CALL TECHNICAL SUPPORT AT 1-800-798-0813

Parts List			
ITEM	QTY	PART NUMBER	DESCRIPTION
1	4	1/2-13 x 3	HEX BOLT
2	4	1/2"	LOCK WASHER
3	4	M12 - 1.25 x 25 HEX	HEX BOLT
4	4	1/2"	CONICAL TOOTHED WASHER
5	3	HexCapScrewInch	
6	3	5/16"	WASHER
7	3	5/16-18 HEX NUT	5/16-18 HEX NUT
8	4	CM-116415-CT	CABLE TIE 11/64 X 15" 50# UV BLACK

TOOLS REQUIRED
RATCHET
1/2", 3/4" SOCKET
TORQUE WRENCH

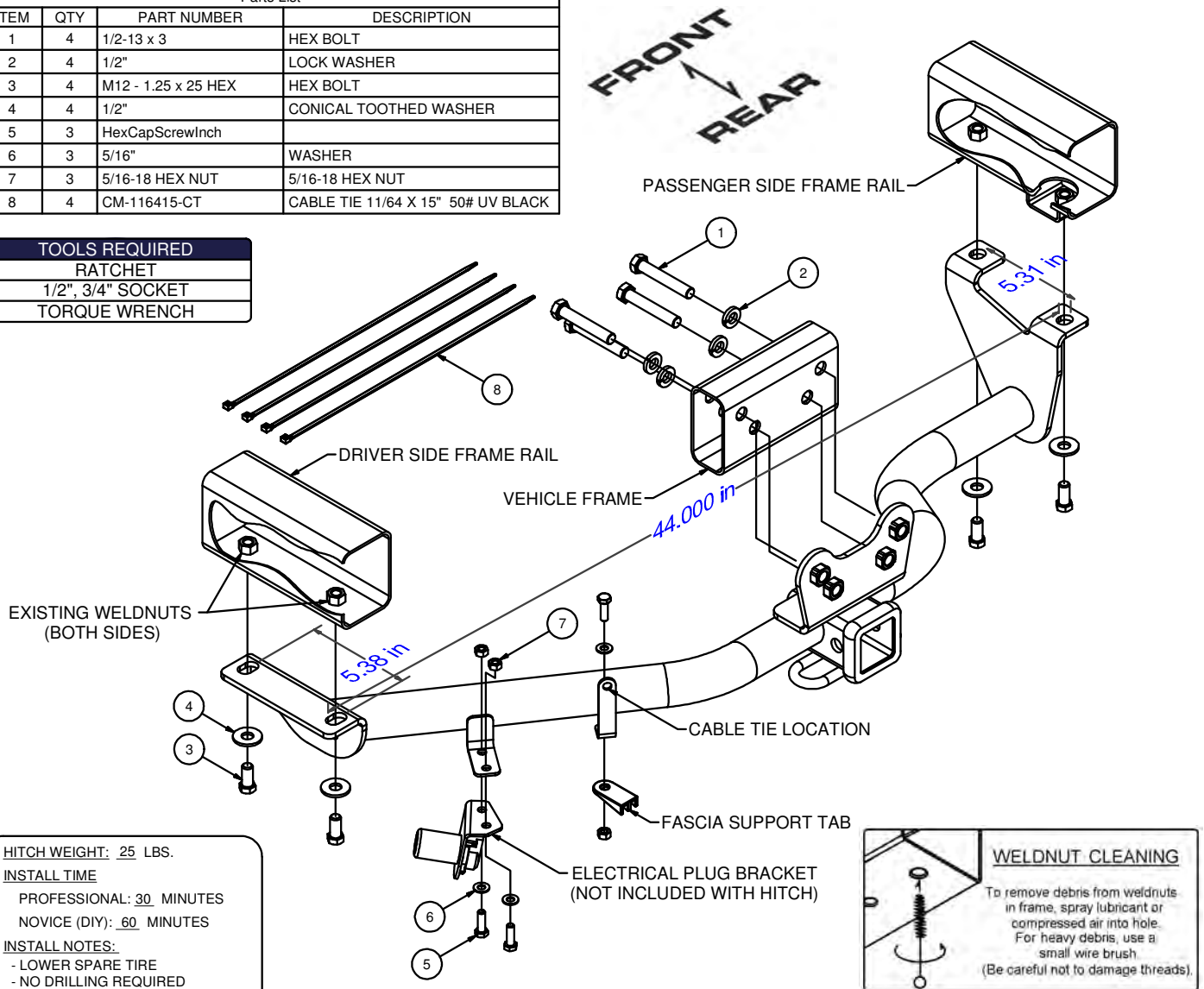

HITCH WEIGHT: 25 LBS.

INSTALL TIME

PROFESSIONAL: 30 MINUTES

NOVICE (DIY): 60 MINUTES

INSTALL NOTES:

- LOWER SPARE TIRE
- NO DRILLING REQUIRED
- WELDNUT CLEANING MAY BE REQUIRED

INSTALLATION STEPS

1. Lower spare tire.
2. Raise hitch into position and attach center of hitch to frame using (4) 1/2-13 x 3 bolts. (Finger tight)
3. Attach hitch to existing weldnuts on driver and passenger side frame rails using M12 hardware. (Finger tight)
4. Torque all 1/2 in hardware to 110 ft-lbs, M12 hardware to 86 ft-lbs, and 5/16 to 24 ft-lbs.
5. Attach fascia support tab to hitch using 5/16 in hardware.
6. Attach electrical plug bracket to hitch using 5/16 in hardware.
7. Use cable ties to secure electrical wiring and raise spare tire back into position.

PERIODICALLY CHECK THIS RECEIVER HITCH TO ENSURE THAT ALL FASTENERS ARE TIGHT AND THAT ALL STRUCTURAL COMPONENTS ARE SOUND.

Curt Manufacturing Inc., warrants this product to be free of defects in material and/or workmanship at the time of retail purchase by the original purchaser. If the product is found to be defective, Curt Manufacturing Inc., may repair or replace the product, at their option, when the product is returned, prepaid, with proof of purchase. Alteration to, misuse of, or improper installation of this product voids the warranty. Curt Manufacturing Inc.'s liability is limited to repair or replacement of products found to be defective, and specifically excludes liability for incidental or consequential loss or damage.