



# 13010 INSTALLATION INSTRUCTIONS



Safety glasses should be worn at all times while installing this product.

YEARS: 2010

MAKE: MERCEDES

MODEL: G550, G55 AMG

STYLE: SUV

**WARNING: NEVER EXCEED YOUR VEHICLE MANUFACTURER'S RECOMMENDED TOWING CAPACITY**

**WEIGHT CARRYING:**  
TRAILER WEIGHT: 4,000 LBS.  
TONGUE WEIGHT: 400 LBS.

**WARNING:**  
WE RECOMMEND THE USE OF 18050 STABILIZING STRAPS FOR ALL NON-TRAILER (WHEEL-LESS) LOADS. PLEASE SEE THE CURT CATALOG OR VISIT US ONLINE AT [WWW.CURTMFG.COM](http://WWW.CURTMFG.COM) FOR FURTHER INFORMATION.

**INSTALLATION TIME: 40 MIN.**

THE INSTALL TIME LISTED IS FOR PROFESSIONAL INSTALLERS. IF YOU ARE HESITANT TO UNDERTAKE THIS TASK ON YOUR OWN, CONTACT AN AUTHORIZED CURT INSTALLER FOR ADDITIONAL ASSISTANCE.

**INSTALLATION REQUIRES:**

<b>RATCHET</b>	<b>SOCKET</b>	<b>TAPE MEASURE</b>
<b>MARKER</b>	<b>POWER DRILL</b>	<b>DRILL BIT 9/16"</b>
<b>UTILITY KNIFE</b>	<b>TORQUE WRENCH</b>	<b>SAFETY GLASSES</b>

**INSTALLATION TIPS:**

- BEFORE YOU BEGIN INSTALLATION, READ ALL INSTRUCTIONS THOROUGHLY.
- TO EASE INSTALLATION, 2 PEOPLE MAY BE REQUIRED.
- USING PROPER TOOLS WILL GREATLY IMPROVE THE QUALITY OF THE INSTALL AND REDUCE THE TIME REQUIRED.
- NEED HELP OR HAVE SOME QUESTIONS? CALL TECHNICAL SUPPORT AT 800.798.0813

**LEVEL OF DIFFICULTY: MODERATE**

<b>EASY</b>	<b>MODERATE</b>	<b>HARD</b>
	<b>REMOVE SKID PLATE</b>	
	<b>DRILL (4) HOLES</b>	

**VEHICLE PHOTO:**



REPRESENTATIVE PHOTO

**HITCH ILLUSTRATION:**

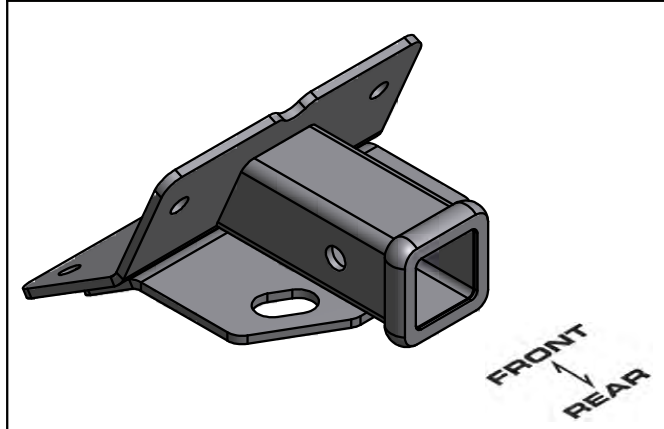

MAKE SURE YOUR HITCH MATCHES

**PERIODICALLY CHECK THIS RECEIVER HITCH TO ENSURE ALL FASTENERS ARE TIGHT AND ALL STRUCTURAL COMPONENTS ARE SOUND**

CURT Manufacturing Inc. warrants this product to be free of defects in material and/or workmanship at the time of retail purchase by the original purchaser. If the product is found to be defective, Curt Manufacturing Inc. may repair or replace the product at their option, when the product is returned, prepaid, with proof of purchase. Alteration to, misuse of, or improper installation of this product voids the warranty. Curt Manufacturing Inc.'s liability is limited to repair or replacement of products found to be defective, and specifically excludes liability for incidental or consequential loss or damage.

For more information log onto [www.curtmfg.com](http://www.curtmfg.com), & for helpful towing tips log onto [www.hitchinfo.com](http://www.hitchinfo.com)

## INSTALLATION WALKTHROUGH:

Parts List			
ITEM	QTY	PART NUMBER	DESCRIPTION
1	4	1/2-13 x 1	HEX BOLT
2	4	HFN 1213	HEX FLANGE NUT

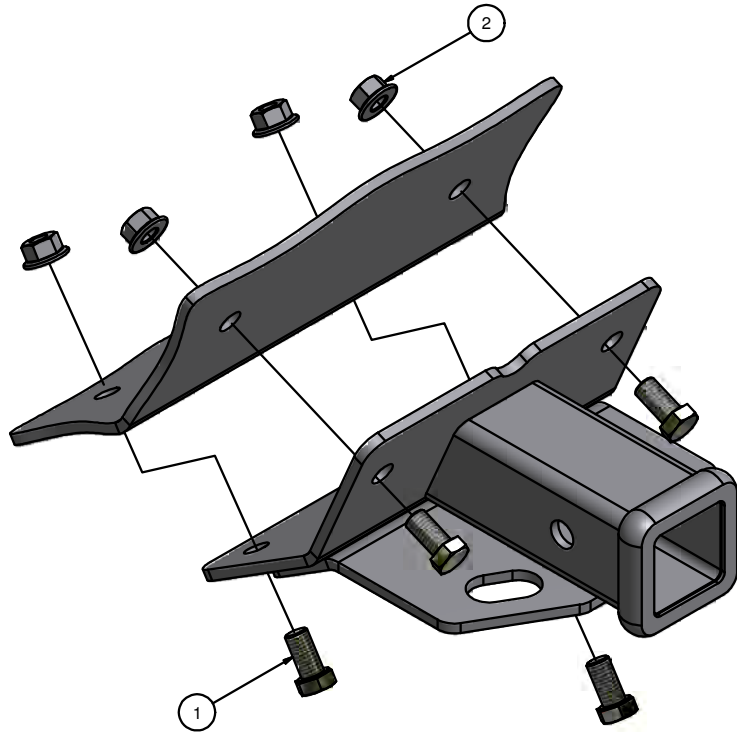

1. Remove vehicle skid plate by removing (2) wires from clips and (17) bolts. This will be reinstalled in STEP 8.



2. Mark center of vehicle skid plate which is at 24.125". (See CENTERING DIAGRAM below)

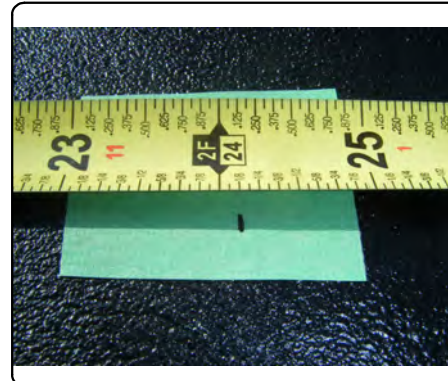

CENTERING DIAGRAM

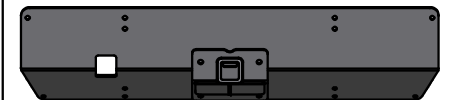

## INSTALLATION WALKTHROUGH:

3. Place hitch on vehicle skid plate and line up centers. NOTE: Make sure the orientation of the hitch is correct and the bend of the hitch is lined up with the bend of the vehicle skid plate.



4. Mark locations of (4) holes and drill using a 9/16" drill bit. NOTE: Push drill through foam to show hole locations for STEP 5.



5. Trim foam on skid plate to allow clearance for 1/2" flange nuts at (4) mounting locations.



6. Attach hitch to vehicle skid plate using the included 1/2" hardware. (As shown in diagram on page 2.)





## INSTALLATION WALKTHROUGH:

7. Torque all 1/2" hardware to 110 ft-lbs.



8. Reinstall vehicle skid plate. Torque factory M8 hardware to 23 ft-lbs.



9. Install is complete.

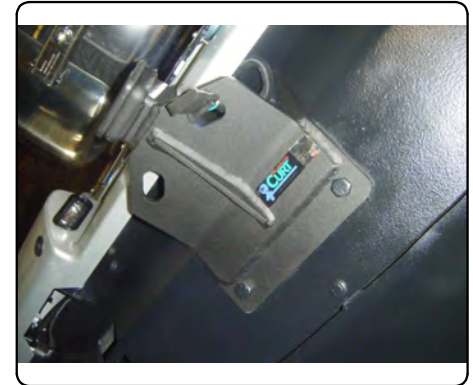

**13010****MERCEDES G550 - G55 AMG**

11/26/2012

GROSS LOAD CAPACITY WHEN USED AS A WEIGHT CARRYING HITCH: 4,000 LBS. TRAILER WEIGHT &amp; 400 LBS. TONGUE WEIGHT.

**\*\*\*DO NOT EXCEED VEHICLE MANUFACTURER'S RECOMMENDED TOWING CAPACITY.\*\*\***

WARNING: ALL NON-TRAILER LOADS APPLIED TO THIS PRODUCT MUST BE SUPPORTED BY 18050 STABILIZING STRAPS.

**\*\* FAILURE TO PROPERLY SUPPORT NON-TRAILER LOADS WILL VOID PRODUCT WARRANTY\*\***

HAVING INSTALLATION QUESTIONS? CALL TECHNICAL SUPPORT AT 1-800-798-0813

Parts List			
ITEM	QTY	PART NUMBER	DESCRIPTION
1	4	HFN 1213	HEX FLANGE NUT
2	4	1/2-13 x 1	HEX BOLT

TOOLS REQUIRED	
RATCHET	
3/4" SOCKET	
10mm, 13mm, 16mm SOCKETS	
DRILL	
9/16" DRILL BIT	
UTILITY KNIFE	
MARKER	
TORQUE WRENCH	

**FRONT**  
↕  
**REAR**

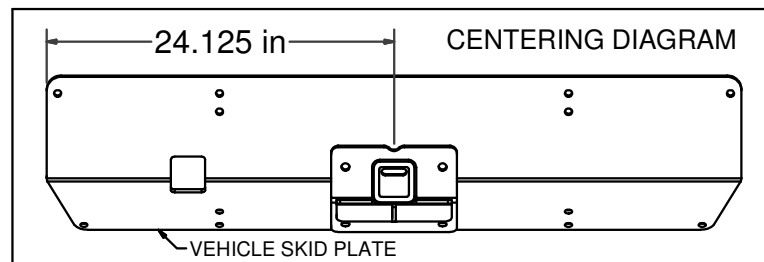
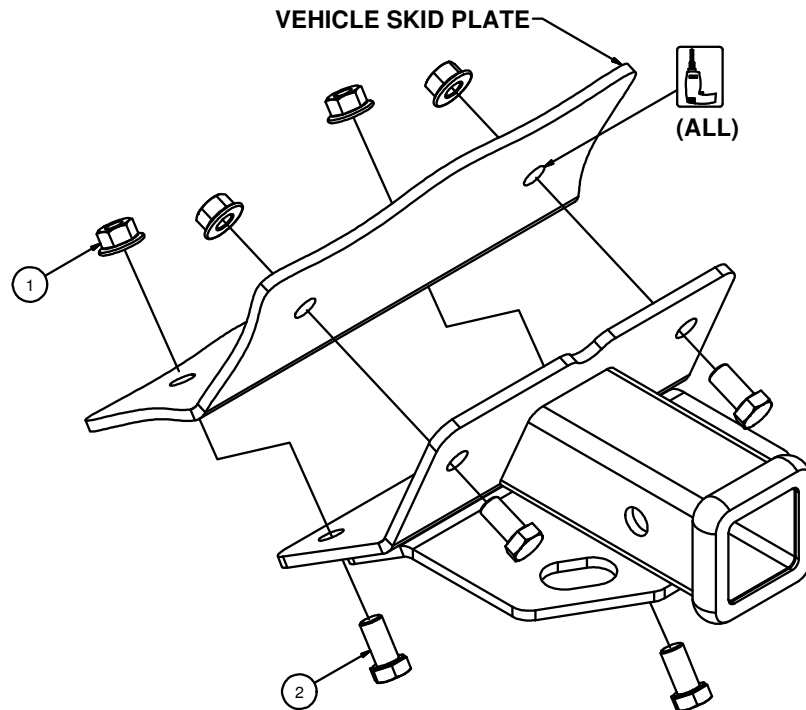

HITCH WEIGHT: 13 LBS.

**INSTALL TIME**

PROFESSIONAL: 40 MINUTES

NOVICE (DIY): 80 MINUTES

**INSTALL NOTES:**

- DRILLING REQUIRED
- REMOVE SKID PLATE

**INSTALLATION STEPS**

1. Remove vehicle skid plate by removing (2) wires from clips and (17) bolts. This will be re-installed in STEP 8.
2. Mark center of vehicle skid plate which is at 24.125". (See CENTERING DIAGRAM above)
3. Place hitch on vehicle skid plate and line up centers. NOTE: Make sure the orientation of the hitch is correct and the bend of the hitch is lined up with the bend of the vehicle skid plate.
4. Mark locations of (4) holes and drill using a 9/16" drill bit. NOTE: Push drill through foam to show hole locations for STEP 5.
5. Trim foam on skid plate to allow clearance for 1/2" flange nuts at (4) mounting locations.
6. Attach hitch to vehicle skid plate using the included 1/2" hardware, as shown above.
7. Torque all 1/2" hardware to 110 ft-lbs.
8. Reinstall vehicle skid plate and torque factory M8 bolts to 23 ft-lbs.

**PERIODICALLY CHECK THIS RECEIVER HITCH TO ENSURE THAT ALL FASTENERS ARE TIGHT AND THAT ALL STRUCTURAL COMPONENTS ARE SOUND.**

Curt Manufacturing Inc., warrants this product to be free of defects in material and/or workmanship at the time of retail purchase by the original purchaser. If the product is found to be defective, Curt Manufacturing Inc., may repair or replace the product, at their option, when the product is returned, prepaid, with proof of purchase. Alteration to, misuse of, or improper installation of this product voids the warranty. Curt Manufacturing Inc.'s liability is limited to repair or replacement of products found to be defective, and specifically excludes liability for incidental or consequential loss or damage.