



13067 INSTALLATION INSTRUCTIONS



Safety glasses should be worn at all times while installing this product.

YEARS: 2007-CURRENT

MAKE: FORD / LINCOLN

MODEL: EDGE / MKX

STYLE: CROSSOVER

WARNING: NEVER EXCEED YOUR VEHICLE MANUFACTURER'S RECOMMENDED TOWING CAPACITY

WEIGHT CARRYING:
TRAILER WEIGHT: 4,000 LBS.
TONGUE WEIGHT: 400 LBS.

WARNING:
WE RECOMMEND THE USE OF 18050 STABILIZING STRAPS FOR ALL NON-TRAILER (WHEEL-LESS) LOADS. PLEASE SEE THE CURT CATALOG OR VISIT US ONLINE AT WWW.CURTMFG.COM FOR FURTHER INFORMATION.



INSTALLATION TIME: 60 MIN.

THE INSTALL TIME LISTED IS FOR PROFESSIONAL INSTALLERS. IF YOU ARE HESITANT TO UNDERTAKE THIS TASK ON YOUR OWN, CONTACT AN AUTHORIZED CURT INSTALLER FOR ADDITIONAL ASSISTANCE.





INSTALLATION TIPS:

1. BEFORE YOU BEGIN INSTALLATION, READ ALL INSTRUCTIONS THOROUGHLY.
2. TO EASE INSTALLATION, 2 PEOPLE MAY BE REQUIRED.
3. USING PROPER TOOLS WILL GREATLY IMPROVE THE QUALITY OF THE INSTALL AND REDUCE THE TIME REQUIRED.
4. NEED HELP OR HAVE SOME QUESTIONS? CALL TECHNICAL SUPPORT AT 800.798.0813

INSTALLATION REQUIRES:

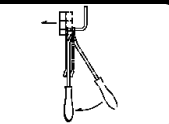
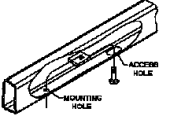
 RATCHET	 TORQUE WRENCH	 6" SOCKET EXTENSION
 3/4" 8mm SOCKET	 SCREW DRIVER	 POWER DRILL
 DRILL BIT 17/32"	 AVIATION SHEARS	 WIRE

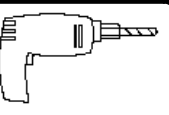
LEVEL OF DIFFICULTY: MODERATE

EASY	MODERATE	HARD
	LOWER EXHAUST	
	FISHWIRE HARDWARE	
	TRIM HEAT SHIELDS	
	DRILL HOLE IN FRAME RAILS	
	FASCIA TRIMMING REQUIRED ON EDGE SPORT MODEL	

VEHICLE PHOTO:



REPRESENTATIVE PHOTO

HITCH ILLUSTRATION:

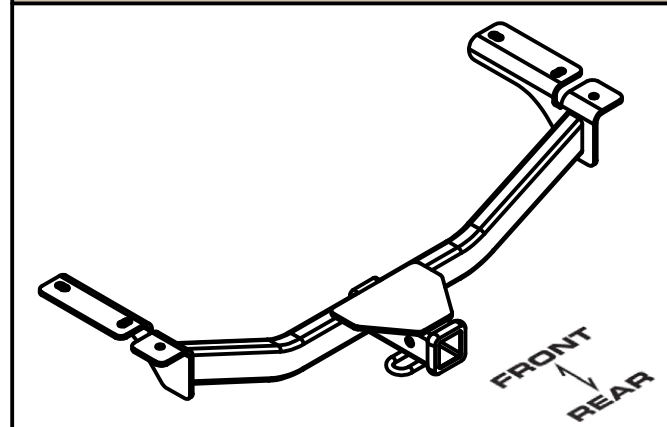

MAKE SURE YOUR HITCH MATCHES

PERIODICALLY CHECK THIS RECEIVER HITCH TO ENSURE ALL FASTENERS ARE TIGHT AND ALL STRUCTURAL COMPONENTS ARE SOUND

CURT Manufacturing Inc. warrants this product to be free of defects in material and/or workmanship at the time of retail purchase by the original purchaser. If the product is found to be defective, Curt Manufacturing Inc. may repair or replace the product at their option, when the product is returned, prepaid, with proof of purchase. Alteration to, misuse of, or improper installation of this product voids the warranty. Curt Manufacturing Inc.'s liability is limited to repair or replacement of products found to be defective, and specifically excludes liability for incidental or consequential loss or damage.

For more information log onto www.curtmfg.com, & for helpful towing tips log onto www.hitchinfo.com

INSTALLATION WALKTHROUGH:

Parts List			
ITEM	QTY	PART NUMBER	DESCRIPTION
1	4	1/2-13 x 1 1/2	CARRIAGE BOLT
2	6	HFN 1213	HEX FLANGE NUT
3	6	CM-SP19	.250 x 1.25 x 3.00" SQUARE HOLE SPACER
4	2	1/2-13 x 1 3/4	CARRIAGE BOLT
5	4	1_2 FISHWIRE	1/2" FISHWIRE

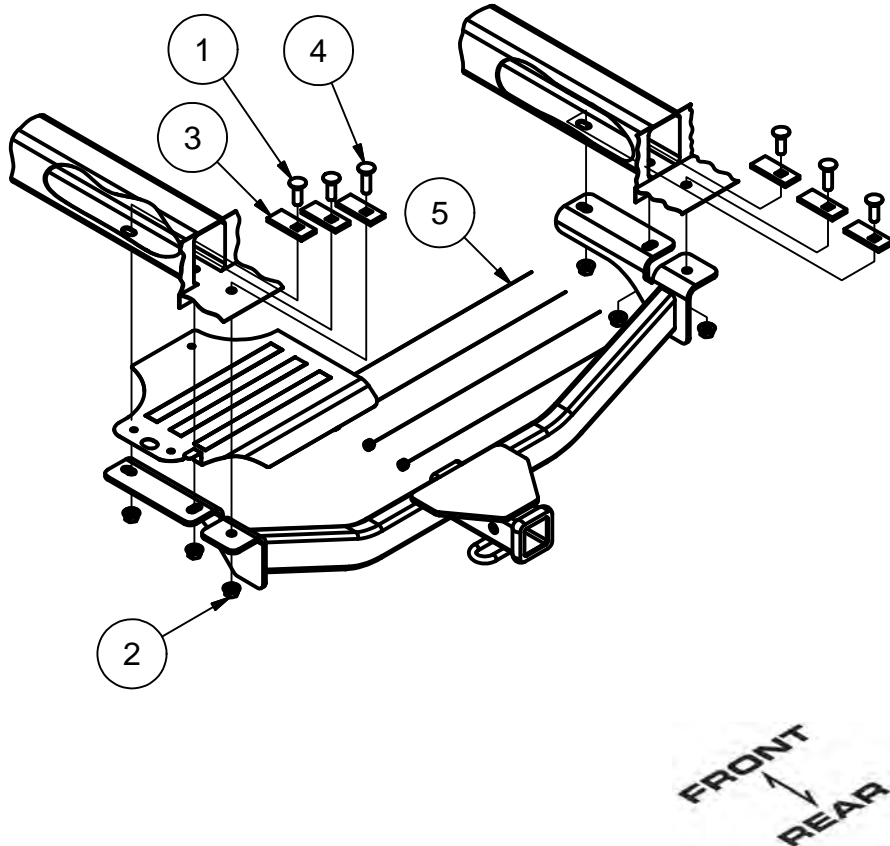

1. Lower exhaust by removing (3) rubber exhaust isolators. Use wire to hold up exhaust to prevent damage to the exhaust tube.



2. Remove heat shield from driver and passenger side of vehicle. The passenger side shield will need (3) screws and (1) plastic plug removed. The driver side shield will need (3) screws, (1) plastic plug, and (1) plastic clip attaching the heat shield to the wiring harness removed.

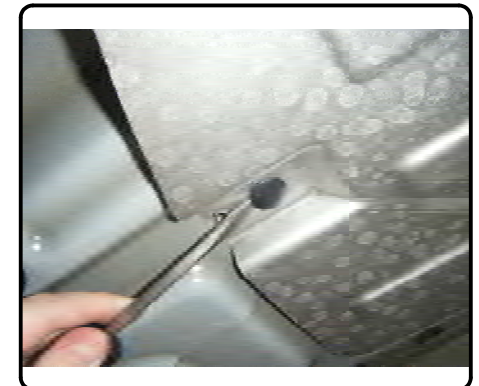

INSTALLATION WALKTHROUGH:

3. Trim tab off of heat shields and reinstall the heat shields. Do not reinstall the (2) screws that attach the heat shield to the frame rails.

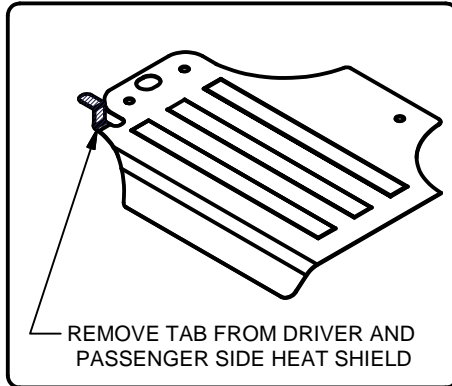

4. Fishwire 1/2-13 x 1 1/2" carriage bolts and CM-SP19 spacers into position through end of frame rails and out mounting holes.



5. Raise hitch into position and secure it with the supplied 1/2" hex flange nuts.



Note:

Ford Edge Sport model, require trimming of fascia. See diagram below for dimension, (dimensions are approximate, confirm fit before trimming).



Fascia Trim Diagram

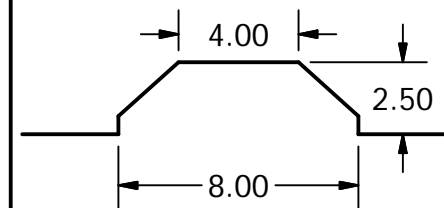

INSTALLATION WALKTHROUGH:

6. Using the hitch as a template, drill the rear holes through the frame rails. Fishwire 1/2-13 x 1 3/4" carriage bolts and CM-SP19 spacers into position and secure with flange nuts.

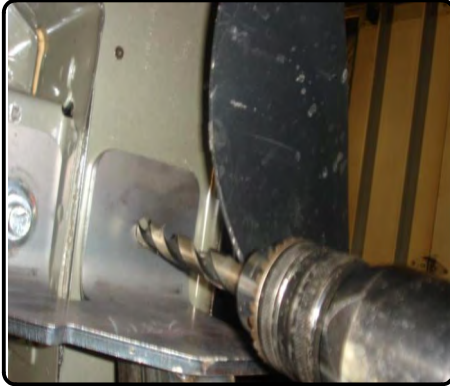

7. Torque 1/2" hardware to 110 lb-ft.



8. Raise exhaust back into position.



13067

FORD EDGE / LINCOLN MKX

7/11/2012

FITS EDGE SPORT WITH FASCIA TRIMMING

GROSS LOAD CAPACITY WHEN USED AS A WEIGHT CARRYING HITCH: 4,000 LBS. TRAILER WEIGHT & 400 LBS. TONGUE WEIGHT.
DO NOT EXCEED VEHICLE MANUFACTURER'S RECOMMENDED TOWING CAPACITY.

Parts List table with columns: ITEM, QTY, PART NUMBER, DESCRIPTION. Includes items like CARRIAGE BOLT, HEX FLANGE NUT, SQUARE HOLE SPACER, and FISHWIRE.

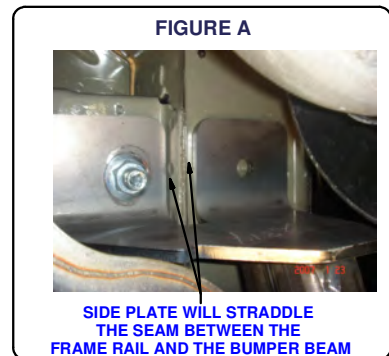
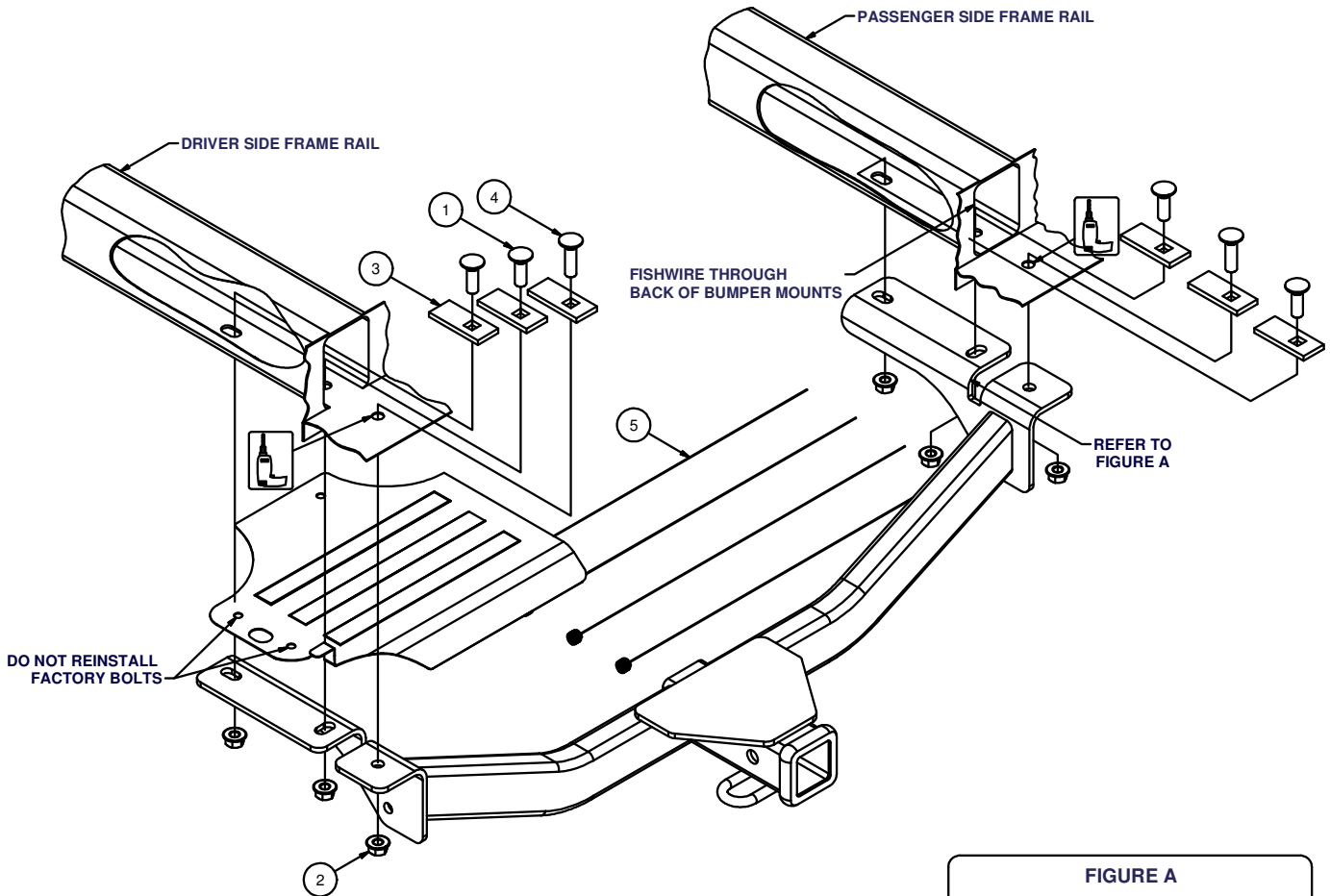
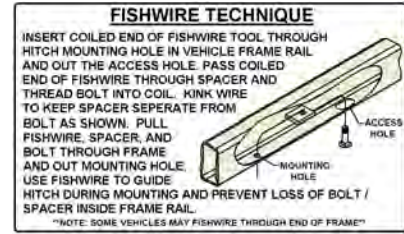

HITCH WEIGHT: 32 LBS.
INSTALL TIME: 60 MINUTES
INSTALL NOTES:
- FISHWIRE HARDWARE
- LOWER EXHAUST
- DRILLING REQUIRED
- HEAT SHIELD TRIMMING REQUIRED
- FACIA TRIMMING MAY BE REQUIRED

FRONT
↑
REAR

PERIODICALLY CHECK THIS RECEIVER HITCH TO ENSURE THAT ALL FASTENERS ARE TIGHT AND THAT ALL STRUCTURAL COMPONENTS ARE SOUND.

Curt Manufacturing Inc., warrants this product to be free of defects in material and/or workmanship at the time of retail purchase by the original purchaser. If the product is found to be defective, Curt Manufacturing Inc., may repair or replace the product, at their option, when the product is returned, prepaid, with proof of purchase.

13067**FORD EDGE / LINCOLN MKX**

7/11/2012

FITS EDGE SPORT WITH FASCIA TRIMMING

GROSS LOAD CAPACITY WHEN USED AS A WEIGHT CARRYING HITCH: 4,000 LBS. TRAILER WEIGHT & 400 LBS. TONGUE WEIGHT.
 *** **DO NOT EXCEED VEHICLE MANUFACTURER'S RECOMMENDED TOWING CAPACITY.*****

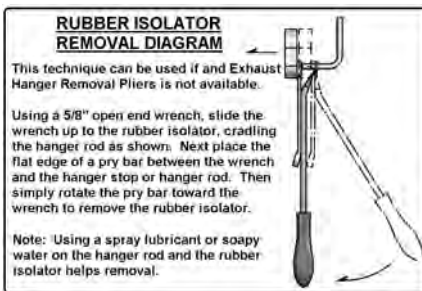

TOOLS REQUIRED
RATCHET
TORQUE WRENCH
6" SOCKET EXTENSION
3/4" SOCKET
8mm SOCKET
FLAT HEAD SCREWDRIVER
DRILL
17/32" DRILL BIT
TIN SNIPS
WIRE

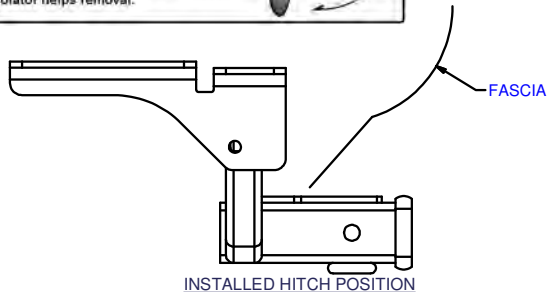

REMOVE TAB FROM DRIVER AND PASSENGER SIDE HEAT SHIELD

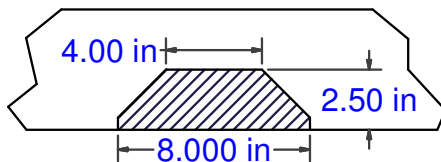
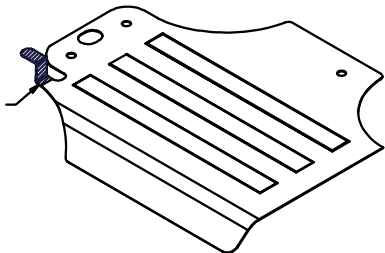

EDGE SPORT FASCIA TRIM DIAGRAM

INSTALLATION STEPS

1. Lower exhaust by removing the rear (3) exhaust hangers. It may be required to use some wire to hold the exhaust up high enough to prevent damage to the exhaust. (See RUBBER ISOLATOR REMOVAL DIAGRAM)
2. Remove heat shield from both sides of vehicle by removing the (3) 6mm bolts and (1) black plastic plug. The driver side heat shield will also be connected to the rear wiring harness by a plastic plug. Once heat shield is removed trim off tab. (See HEAT SHIELD TAB REMOVAL diagram) Reattach heat shield without the screws in the frame rails. Heat shield will then be sandwiched between vehicle frame rails and hitch.
3. Fishwire 1/2 - 13 x 1 1/2" carriage bolts with CM-SP19 spacers through rear of bumper mounts to holes in frame rails, as shown. (See FISHWIRE TECHNIQUE DIAGRAM)
4. Raise hitch into position and secure with 1/2" flange nuts.
(Note: Bumper fascia trimming is required on Edge Sport. See Trim Diagram.)
5. Using the hitch as a template, drill rear holes of hitch, both sides, using a 17/32" drill bit.
6. Fishwire 1/2-13 x 1 3/4" carriage bolt and spacer through back of bumper mounts and attach with 1/2" flange nuts.
7. Torque 1/2" hardware to 110 lb-ft.
8. Reinstall exhaust removed in Step 1.

PERIODICALLY CHECK THIS RECEIVER HITCH TO ENSURE THAT ALL FASTENERS ARE TIGHT AND THAT ALL STRUCTURAL COMPONENTS ARE SOUND.

Curt Manufacturing Inc., warrants this product to be free of defects in material and/or workmanship at the time of retail purchase by the original purchaser. If the product is found to be defective, Curt Manufacturing Inc., may repair or replace the product, at their option, when the product is returned, prepaid, with proof of purchase. Alteration to, misuse of, or improper installation of this product voids the warranty. Curt Manufacturing Inc.'s liability is limited to repair or replacement of products found to be defective, and specifically excludes liability for incidental or consequential loss or damage.