



Safety glasses should be worn at all times while installing this product.

YEARS: 2013-PRESENT

MAKE: INFINITI & NISSAN

MODEL: JX35, QX60 & PATHFINDER

STYLE: SUV

WARNING: NEVER EXCEED YOUR VEHICLE MANUFACTURER'S RECOMMENDED TOWING CAPACITY

WEIGHT CARRYING:
 TRAILER WEIGHT: 4000 LBS.
 TONGUE WEIGHT: 600 LBS.

WEIGHT DISTRIBUTION:
 TRAILER WEIGHT: 5000 LBS.
 TONGUE WEIGHT: 600 LBS.

INSTALLATION TIME: 40 MIN.

THE INSTALL TIME LISTED IS FOR PROFESSIONAL INSTALLERS. IF YOU ARE HESITANT TO UNDERTAKE THIS TASK ON YOUR OWN, CONTACT AN AUTHORIZED CURT INSTALLER FOR ADDITIONAL ASSISTANCE.

INSTALLATION TIPS:

- BEFORE YOU BEGIN INSTALLATION, READ ALL INSTRUCTIONS THOROUGHLY.
- TO EASE INSTALLATION, 2 PEOPLE MAY BE REQUIRED.
- USING PROPER TOOLS WILL GREATLY IMPROVE THE QUALITY OF THE INSTALL AND REDUCE THE TIME REQUIRED.
- NEED HELP OR HAVE SOME QUESTIONS? CALL TECHNICAL SUPPORT AT 800.798.0813



INSTALLATION REQUIRES:

MARKER	MASKING TAPE	RATCHET
SAFETY GLASSES	12mm 18mm 19mm 21mm SOCKET	TAPE MEASURE
TORQUE WRENCH	ROTARY TOOL	

LEVEL OF DIFFICULTY: MODERATE

EASY	MODERATE	CHALLENGING
	CLEAN OUT WELDNUTS	
	TEMPORARILY LOWER SPARE TIRE	
	MINOR FASCIA TRIMMING REQUIRED	
	REMOVE TOW HOOK	
	NO DRILLING REQUIRED	

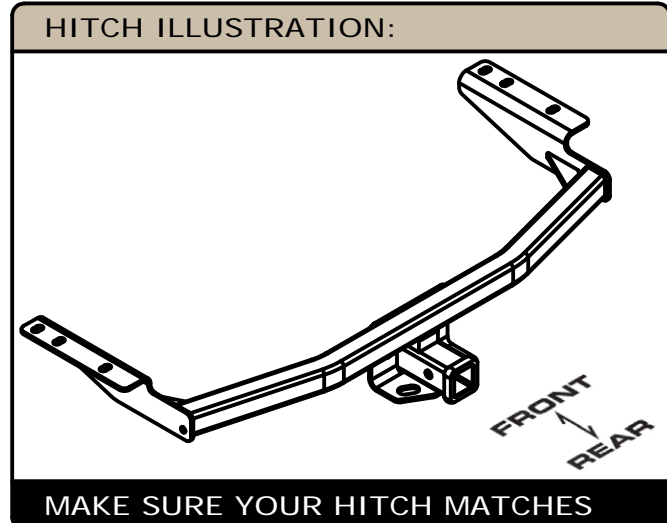

PERIODICALLY CHECK THIS RECEIVER HITCH TO ENSURE ALL FASTENERS ARE TIGHT AND ALL STRUCTURAL COMPONENTS ARE SOUND

CURT Manufacturing LLC. warrants this product to be free of defects in material and/or workmanship at the time of retail purchase by the original purchaser. If the product is found to be defective, Curt Manufacturing LLC. may repair or replace the product at their option, when the product is returned, prepaid, with proof of purchase. Alteration to, misuse of, or improper installation of this product voids the warranty. Curt Manufacturing LLC.'s liability is limited to repair or replacement of products found to be defective, and specifically excludes liability for incidental or consequential loss or damage.

For more information log onto www.curtmfg.com, & for helpful towing tips log onto www.hitchinfo.com

INSTALLATION WALKTHROUGH:

Parts List			
ITEM	QTY	PART NUMBER	DESCRIPTION
1	6	1/2"	CONICAL TOOTHED WASHER
2	6	M12-1.25 x 30mm	HEX BOLT

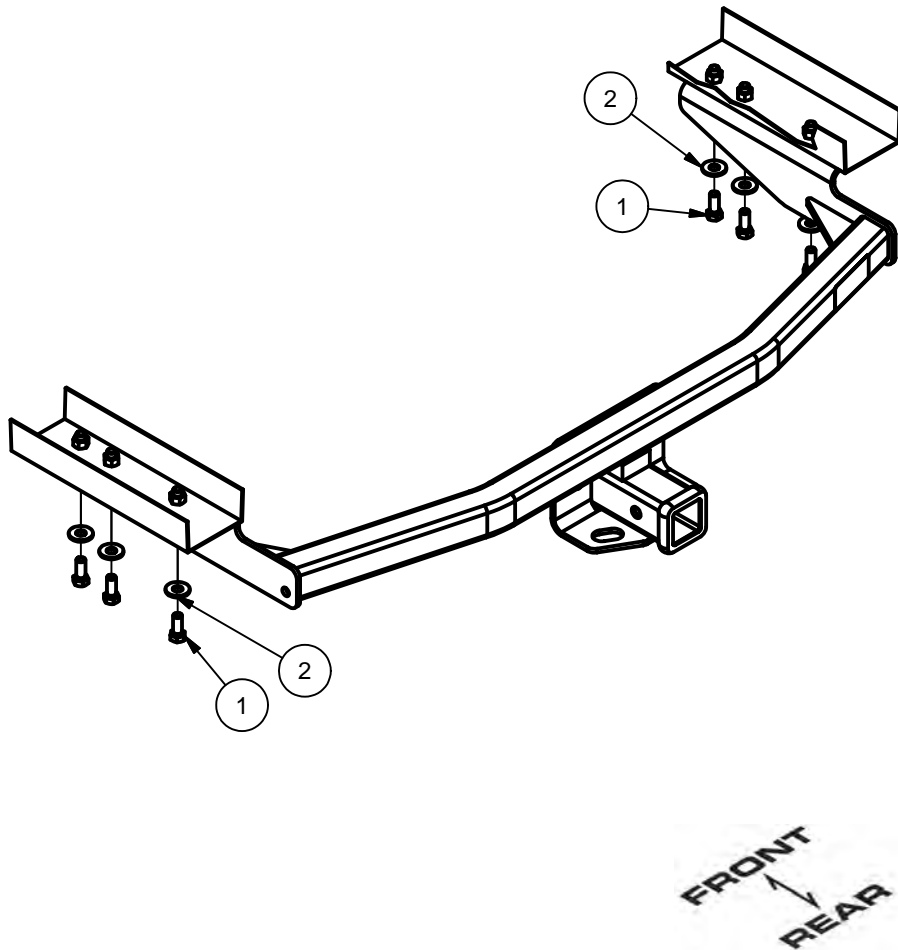

1. Remove tow hook from driver side frame rail. Return tow hook and fasteners to vehicle owner.

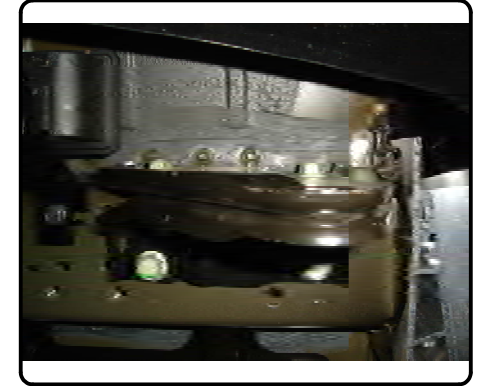
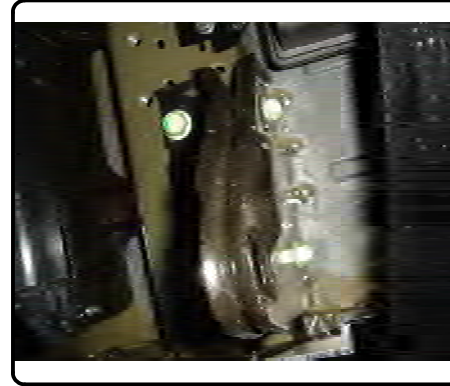

2. Lower spare tire using tire lug wrench or ratchet with 21mm socket.

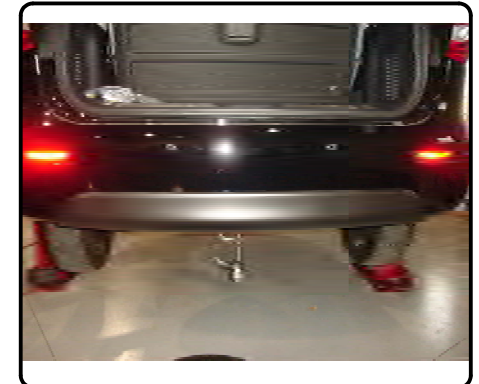

INSTALLATION WALKTHROUGH:

3. Remove fascia mounting brackets by first removing plastic clips on bottom of fascia and then unbolting brackets from bumper. Retain for reinstallation after hitch installation.



4. Locate center of vehicle fascia and mark area as shown for fascia trimming, approximately 2 1/2" x 1 3/8". Trim fascia.

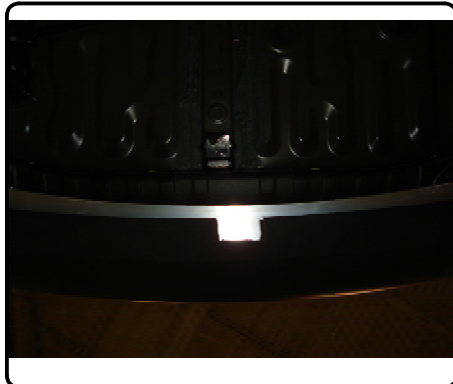
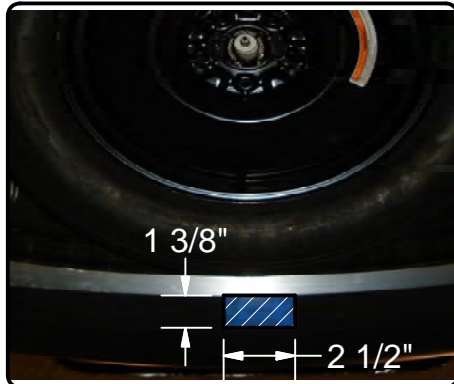

5. Raise hitch into position and secure with M12 x 1.25 x 30mm hex bolts and 1/2" conical toothed washers into existing weldnuts. Torque all M12 fasteners to 86 ft-lbs.
6. Reinstall fascia mounting brackets.

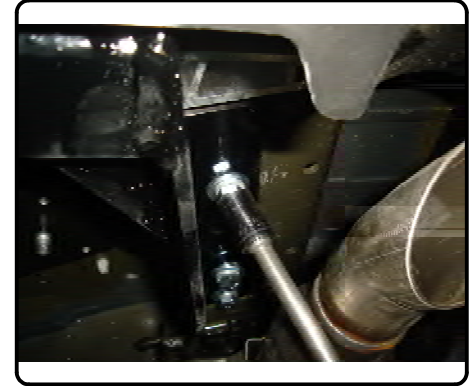
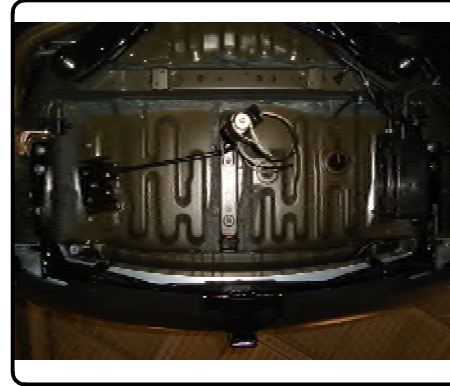

7. Raise spare tire back into position.
Installation is complete.

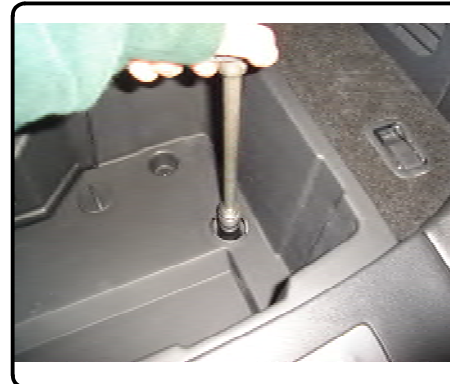

13126**INFINITI JX35, QX60 & NISSAN PATHFINDER****10/16/13**

GROSS LOAD CAPACITY WHEN USED AS A WEIGHT CARRYING HITCH: 4000 LBS. TRAILER WEIGHT & 600 LBS. TONGUE WEIGHT.
GROSS LOAD CAPACITY WHEN USED AS A WEIGHT DISTRIBUTION HITCH: 5000 LBS. TRAILER WEIGHT & 600 LBS. TONGUE WEIGHT

DO NOT EXCEED VEHICLE MANUFACTURER'S RECOMMENDED TOWING CAPACITY.

HAVING INSTALLATION QUESTIONS? CALL TECHNICAL SUPPORT AT 1-800-798-0813

Parts List			
ITEM	QTY	PART NUMBER	DESCRIPTION
1	6	M12-1.25 x 30mm	HEX BOLT
2	6	1/2"	CONICAL TOOTHED WASHER

TOOLS REQUIRED	
RATCHET	
TORQUE WRENCH	
12mm SOCKET	
18mm SOCKET	
19mm SOCKET	
21mm SOCKET	

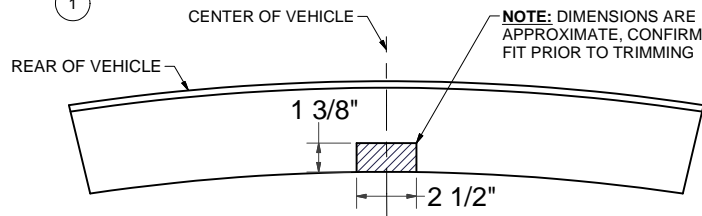
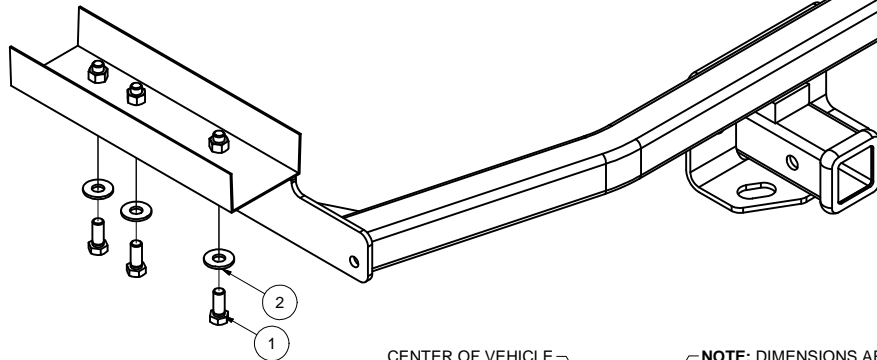
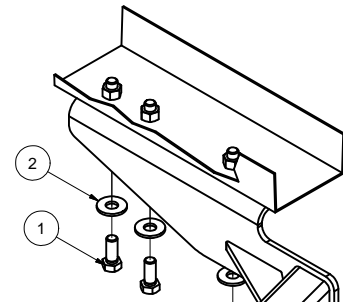
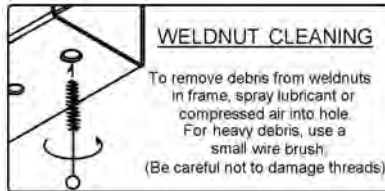

HITCH WEIGHT: 22 LBS.

INSTALL TIME

PROFESSIONAL: 40 MINUTES

NOVICE (DIY): 85 MINUTES

INSTALL NOTES:

- NO DRILLING REQUIRED
- MINOR FASCIA TRIM
- REMOVE TOW HOOK
- LOWER SPARE TIRE

INSTALLATION STEPS

1. Remove tow hook from driver side frame rail. Return tow hook and fasteners to vehicle owner.
2. Lower spare tire using tire lug wrench or ratchet with 21mm socket.
3. Remove fascia mounting brackets by first removing plastic clips on bottom of fascia and then unbolting brackets from bumper. Retain for reinstallation after hitch installation.
4. Mark area as shown for fascia trimming, approximately 2 1/2" x 1 3/8". Trim fascia.
5. Raise hitch into position and secure with M12 x 1.25 x 30mm hex bolts and 1/2" conical toothed washers into existing weldnuts. Torque all M12 fasteners to 86 ft-lbs.
6. Reinstall fascia mounting brackets.
7. Raise spare tire back into place.

PERIODICALLY CHECK THIS RECEIVER HITCH TO ENSURE THAT ALL FASTENERS ARE TIGHT AND THAT ALL STRUCTURAL COMPONENTS ARE SOUND.

Curt Manufacturing LLC., warrants this product to be free of defects in material and/or workmanship at the time of retail purchase by the original purchaser. If the product is found to be defective, Curt Manufacturing LLC., may repair or replace the product, at their option, when the product is returned, prepaid, with proof of purchase. Alteration to, misuse of, or improper installation of this product voids the warranty. Curt Manufacturing LLC.'s liability is limited to repair or replacement of products found to be defective, and specifically excludes liability for incidental or consequential loss or damage.