



Safety glasses should be worn at all times while installing this product.

YEARS: 2012-PRESENT

MAKE: LAND ROVER

MODEL: RANGE ROVER EVOQUE

STYLE: CROSSOVER

WARNING: NEVER EXCEED YOUR VEHICLE MANUFACTURER'S RECOMMENDED TOWING CAPACITY

WEIGHT CARRYING:
 TRAILER WEIGHT: 4,000 LBS.
 TONGUE WEIGHT: 600 LBS.

WARNING:
 WE RECOMMEND THE USE OF 18050 STABILIZING STRAPS FOR ALL NON-TRAILER (WHEEL-LESS) LOADS. PLEASE SEE THE CURT CATALOG OR VISIT US ONLINE AT WWW.CURTMFG.COM FOR FURTHER INFORMATION.

INSTALLATION TIME: 30 MIN.

THE INSTALL TIME LISTED IS FOR PROFESSIONAL INSTALLERS. IF YOU ARE HESITANT TO UNDERTAKE THIS TASK ON YOUR OWN, CONTACT AN AUTHORIZED CURT INSTALLER FOR ADDITIONAL ASSISTANCE.

INSTALLATION REQUIRES:

AVIATION SHEARS	CUT-OFF WHEEL	TORQUE WRENCH
MASKING TAPE	PRY BAR	RATCHET
SAFETY GLASSES	10mm 15mm 22mm 3/4" SOCKET	T-30 TORXBIT SOCKET
TAPE MEASURE		

INSTALLATION TIPS:

- BEFORE YOU BEGIN INSTALLATION, READ ALL INSTRUCTIONS THOROUGHLY.
- TO EASE INSTALLATION, 2 PEOPLE MAY BE REQUIRED.
- USING PROPER TOOLS WILL GREATLY IMPROVE THE QUALITY OF THE INSTALL AND REDUCE THE TIME REQUIRED.
- NEED HELP OR HAVE SOME QUESTIONS? CALL TECHNICAL SUPPORT AT 800.798.0813

LEVEL OF DIFFICULTY: MODERATE

EASY	MODERATE	CHALLENGING
	REVERSE FISHWIRE FASTENERS	
	TEMPORARILY LOWER EXHAUST	
	NO DRILLING REQUIRED	
	FASCIA TRIMMING REQUIRED	
	HEAT SHIELD REMOVAL <u>OR</u> TRIMMING REQUIRED	

VEHICLE PHOTO:



REPRESENTATIVE PHOTO

HITCH ILLUSTRATION:

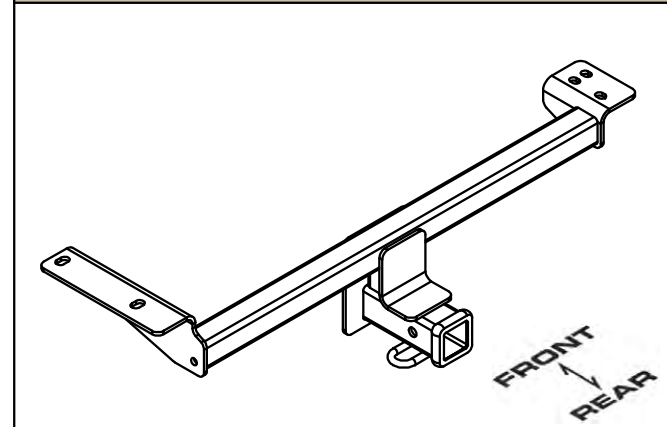

MAKE SURE YOUR HITCH MATCHES

PERIODICALLY CHECK THIS RECEIVER HITCH TO ENSURE ALL FASTENERS ARE TIGHT AND ALL STRUCTURAL COMPONENTS ARE SOUND

CURT Manufacturing LLC. warrants this product to be free of defects in material and/or workmanship at the time of retail purchase by the original purchaser. If the product is found to be defective, Curt Manufacturing LLC. may repair or replace the product at their option, when the product is returned, prepaid, with proof of purchase. Alteration to, misuse of, or improper installation of this product voids the warranty. Curt Manufacturing LLC.'s liability is limited to repair or replacement of products found to be defective, and specifically excludes liability for incidental or consequential loss or damage.

For more information log onto www.curtmfg.com, & for helpful towing tips log onto www.hitchinfo.com

INSTALLATION WALKTHROUGH:

Parts List			
ITEM	QTY	PART NUMBER	DESCRIPTION
1	1	M14 - 2 x 110 HEX	HEX BOLT
2	1	9/16" CONICAL WASHER	CONICAL TOOTHED WASHER
3	1	1/2-13 x 1 3/4	CARRIAGE BOLT
4	1	CM-SP6	.250" SQUARE HOLE SPACER
5	1	1/2	CONICAL TOOTHED WASHER
6	1	1/2-13	HEX NUT
7	3	M12 - 1.75 x 35	HEX FLANGE BOLT
8	1	1_2 FISHWIRE	1/2" FISHWIRE

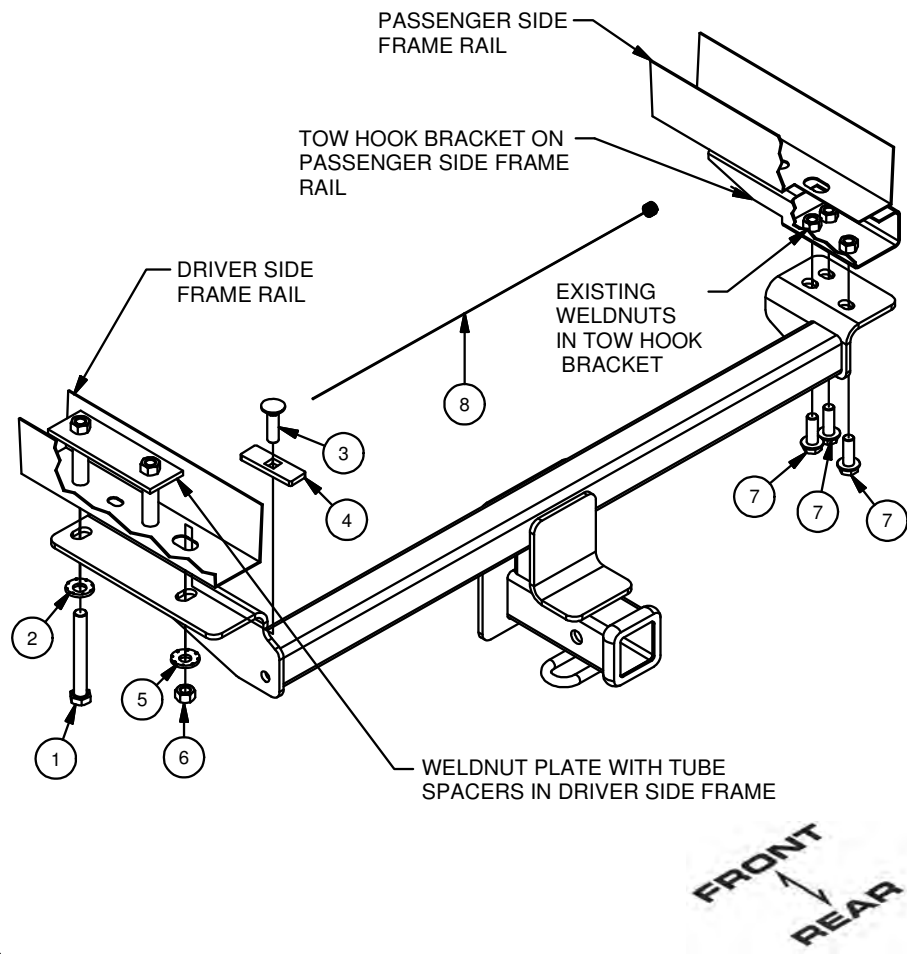

1. Lower exhaust by removing bolt which attaches exhaust hanger bracket on passenger side frame rail, then disconnecting 2 rubber isolators. Support exhaust to prevent it from being damaged.



2. Remove rear heat shield at vehicle fascia by removing 4 hex bolts and 8 Torx bolts. Heat shield may either be trimmed and reinstalled or permanently removed.



INSTALLATION WALKTHROUGH:

3. Reverse fishwire 1/2" carriage bolt and spacer up through slot in driver side frame rail and back down through slot.



4. Trim fascia as shown, approximately 3 3/4" long x 1" wide (See Fascia Trim Diagram).

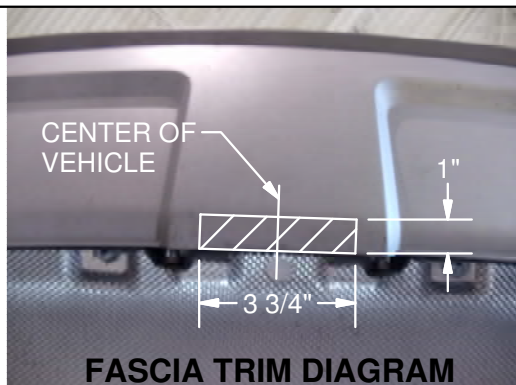

5. Raise hitch into position, being careful not to push 1/2" carriage bolt back into frame.

6. Install remaining fasteners as shown. Torque all 1/2" fasteners to 110 ft-lbs, torque all M12 fasteners to 79 ft-lbs, torque all M14 fasteners to 126 ft-lbs.



7. Raise exhaust back into position.

Installation is complete

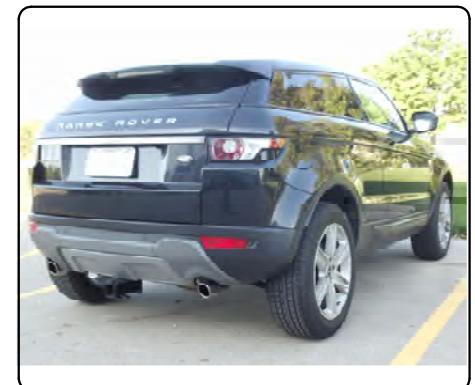

13128**LAND ROVER RANGE ROVER EVOQUE****1-30-13****GROSS LOAD CAPACITY WHEN USED AS A WEIGHT CARRYING HITCH: 4,000 LBS. TRAILER WEIGHT & 600 LBS. TONGUE WEIGHT.*******DO NOT EXCEED VEHICLE MANUFACTURER'S RECOMMENDED TOWING CAPACITY.*******WARNING: ALL NON-TRAILER LOADS APPLIED TO THIS PRODUCT MUST BE SUPPORTED BY 18050 STABILIZING STRAPS.****** FAILURE TO PROPERLY SUPPORT NON-TRAILER LOADS WILL VOID PRODUCT WARRANTY******HAVING INSTALLATION QUESTIONS? CALL TECHNICAL SUPPORT AT 1-800-798-0813**

Parts List			
ITEM	QTY	PART NUMBER	DESCRIPTION
1	1	M14 - 2 x 110 HEX	HEX BOLT
2	1	9/16" CONICAL WASHER	CONICAL TOOTHED WASHER
3	1	1/2-13 x 1 3/4	CARRIAGE BOLT
4	1	CM-SP6	.250" SQUARE HOLE SPACER
5	1	1/2	CONICAL TOOTHED WASHER
6	1	1/2-13	HEX NUT
7	3	M12 - 1.75 x 35	HEX FLANGE BOLT
8	1	1_2 FISHWIRE	1/2" FISHWIRE

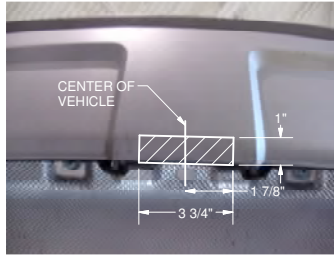
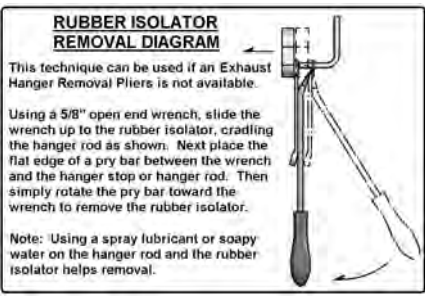
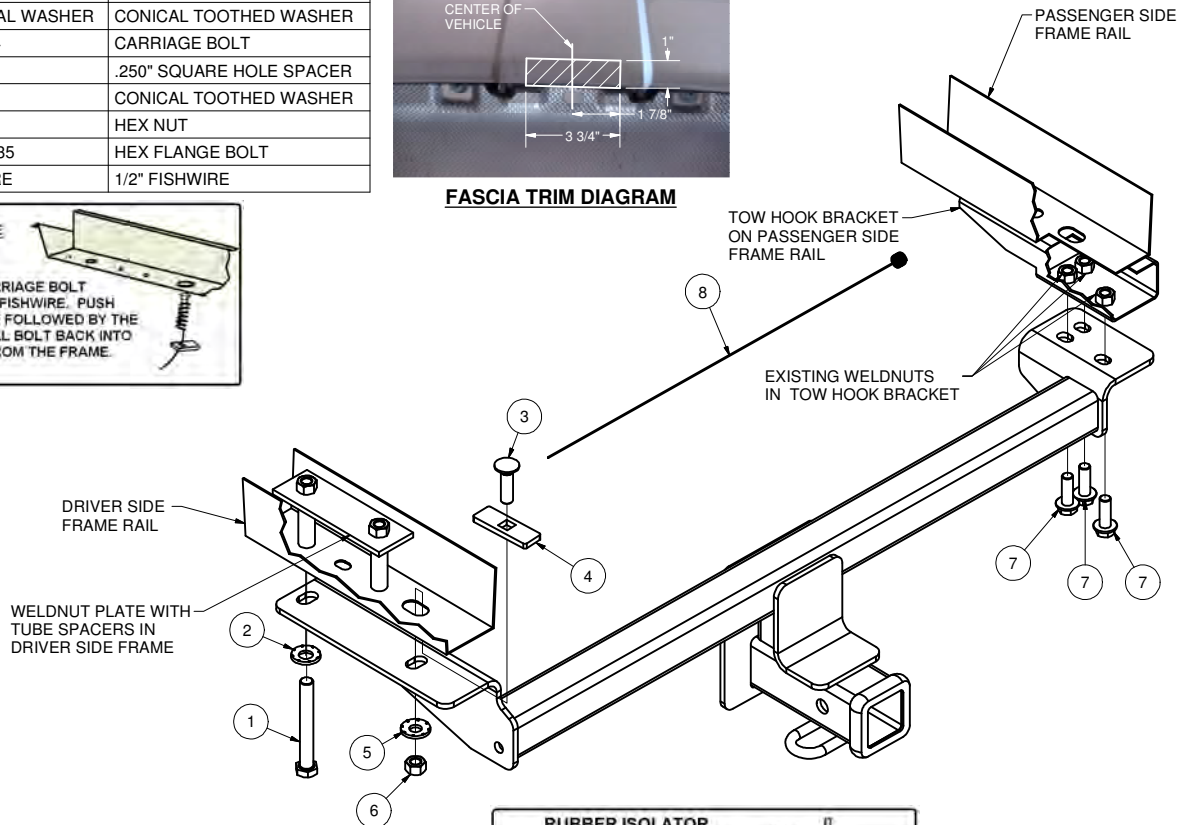
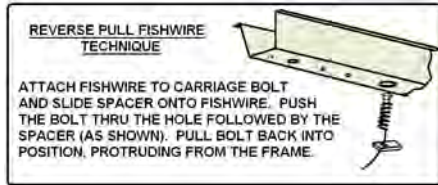
**FASCIA TRIM DIAGRAM**

FRONT
REAR

HITCH WEIGHT: 30 LBS.

INSTALL TIME

PROFESSIONAL: 30 MINUTES

NOVICE (DIY): 65 MINUTES

INSTALL NOTES:

- NO DRILLING REQUIRED
- REVERSE FISHWIRE HARDWARE
- LOWER EXHAUST
- REMOVE OR TRIM HEAT SHIELD
- FASCIA TRIMMING REQUIRED

TOOLS REQUIRED	
TORQUE WRENCH	
RATCHET	
PRY BAR	
TAPE MEASURE	
CUT OFF WHEEL	
TIN SNIPS	
10mm, 15mm, 22mm SOCKETS	
3/4" SOCKET	
T-30 TORX BIT	

INSTALLATION STEPS

1. Lower exhaust by removing bolt which attaches exhaust hanger bracket on passenger side frame rail, then disconnecting 2 rubber isolators. Support exhaust to prevent it from being damaged.
2. Remove rear heat shield at vehicle fascia by removing 4 hex bolts and 8 Torx bolts. Heat shield may either be trimmed and reinstalled or permanently removed.
3. Reverse fishwire 1/2" carriage bolt and spacer up through slot in driver side frame rail and back down through slot.
4. Trim fascia as shown, approximately 3 3/4" long X 1" wide (See Fascia Trim Diagram).
5. Raise hitch into position, being careful not to push 1/2" carriage bolt back into frame.
6. Install remaining fasteners as shown. Torque all 1/2" fasteners to 110 ft-lbs, torque all M12 fasteners to 79 ft-lbs, torque all M14 fasteners to 126 ft-lbs.
7. Raise exhaust back into position.

PERIODICALLY CHECK THIS RECEIVER HITCH TO ENSURE THAT ALL FASTENERS ARE TIGHT AND THAT ALL STRUCTURAL COMPONENTS ARE SOUND.

Curt Manufacturing LLC., warrants this product to be free of defects in material and/or workmanship at the time of retail purchase by the original purchaser. If the product is found to be defective, Curt Manufacturing LLC., may repair or replace the product, at their option, when the product is returned, prepaid, with proof of purchase. Alteration, to misuse of, or improper installation of this product voids the warranty. Curt Manufacturing LLC.'s liability is limited to repair or replacement of products found to be defective, and specifically excludes liability for incidental or consequential loss or damage.