



Safety glasses should be worn at all times while installing this product.

YEARS: 2013-PRESENT

MAKE: FORD

MODEL: ESCAPE (EXCLUDING S MODEL)

STYLE: SUV

WARNING: NEVER EXCEED YOUR VEHICLE MANUFACTURER'S RECOMMENDED TOWING CAPACITY







WEIGHT CARRYING:
 TRAILER WEIGHT: 3,500 LBS.
 TONGUE WEIGHT: 525 LBS.

WEIGHT DISTRIBUTION:
 TRAILER WEIGHT: 5,000 LBS.
 TONGUE WEIGHT: 525 LBS.

INSTALLATION TIME: 20 MIN.

THE INSTALL TIME LISTED IS FOR PROFESSIONAL INSTALLERS. IF YOU ARE HESITANT TO UNDERTAKE THIS TASK ON YOUR OWN, CONTACT AN AUTHORIZED CURT INSTALLER FOR ADDITIONAL ASSISTANCE.

INSTALLATION REQUIRES:

 SAFETY GLASSES	 DIE GRINDER	 BOXED END WRENCH 11/16"
 RATCHET	 SOCKET 3/4"	 TORQUE WRENCH

INSTALLATION TIPS:

- BEFORE YOU BEGIN INSTALLATION, READ ALL INSTRUCTIONS THOROUGHLY.
- TO EASE INSTALLATION, 2 PEOPLE MAY BE REQUIRED.
- USING PROPER TOOLS WILL GREATLY IMPROVE THE QUALITY OF THE INSTALL AND REDUCE THE TIME REQUIRED.
- NEED HELP OR HAVE SOME QUESTIONS? CALL TECHNICAL SUPPORT AT 800.798.0813

LEVEL OF DIFFICULTY: EASY

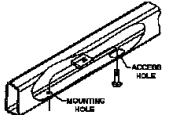
EASY	MODERATE	CHALLENGING
	HOLE ENLARGEMENT REQUIRED	
	FISHWIRING REQUIRED	

VEHICLE PHOTO:



REPRESENTATIVE PHOTO

HITCH ILLUSTRATION:

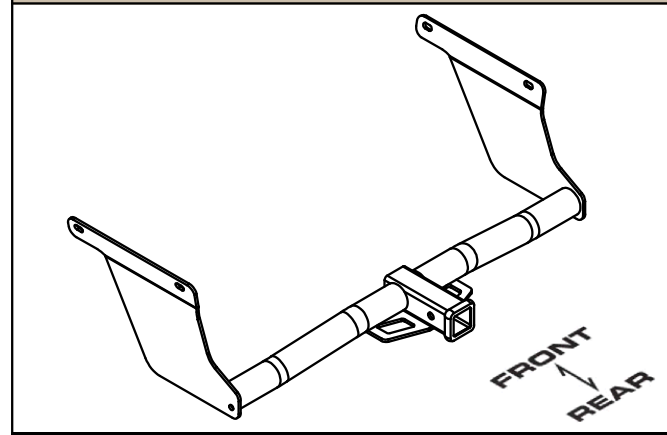

MAKE SURE YOUR HITCH MATCHES

PERIODICALLY CHECK THIS RECEIVER HITCH TO ENSURE ALL FASTENERS ARE TIGHT AND ALL STRUCTURAL COMPONENTS ARE SOUND

CURT Manufacturing LLC. warrants this product to be free of defects in material and/or workmanship at the time of retail purchase by the original purchaser. If the product is found to be defective, Curt Manufacturing LLC. may repair or replace the product at their option, when the product is returned, prepaid, with proof of purchase. Alteration to, misuse of, or improper installation of this product voids the warranty. Curt Manufacturing LLC.'s liability is limited to repair or replacement of products found to be defective, and specifically excludes liability for incidental or consequential loss or damage.

For more information log onto www.curtmfg.com, & for helpful towing tips log onto www.hitchinfo.com

INSTALLATION WALKTHROUGH:

Parts List			
ITEM	QTY	PART NUMBER	DESCRIPTION
1	4	CM-SP10	.250 x 1.00 x 2.50" SQUARE HOLE SPACER
2	4	1/2-13 x 1 1/2, GR8	CARRIAGE BOLT
3	4	HFN 1213, GR8	HEX FLANGE NUT
4	4	1_2 FISHWIRE	1/2" FISHWIRE

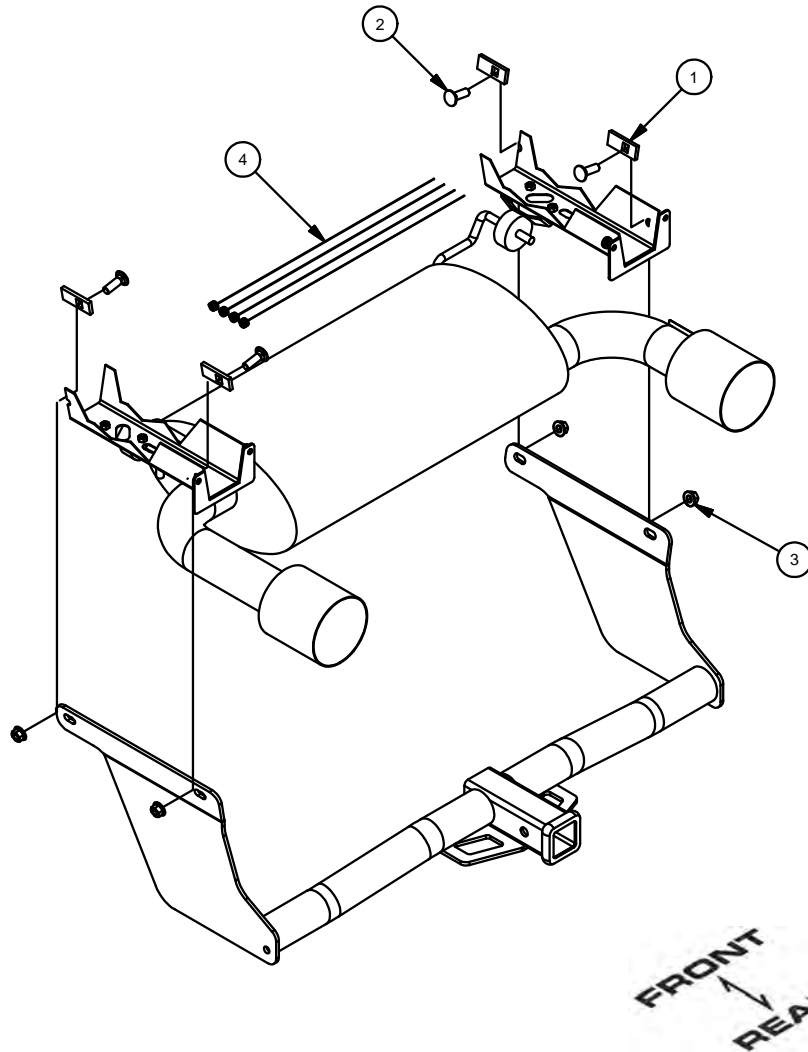

1. Enlarge access holes for square hole spacers with a die grinder.
Fishwire 1/2" bolts and spacers into vehicle frame for the (2) side plate mounting points on each side of the vehicle.

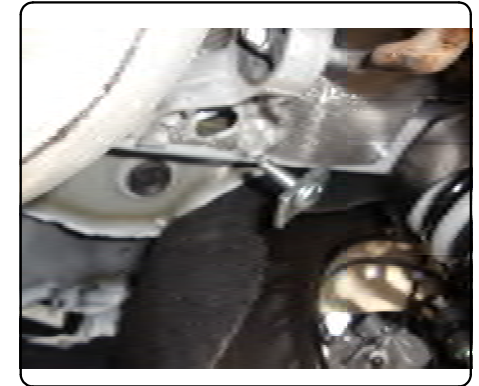
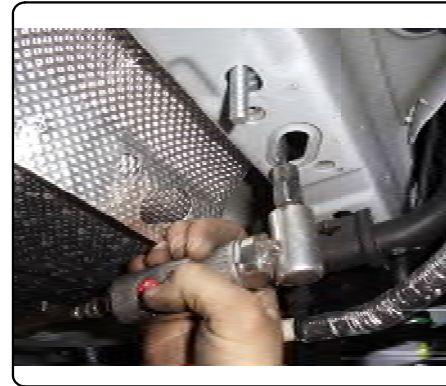

2. Place hitch underneath vehicle and route fishwire through side plate mounting holes. It may be necessary to use two people to raise the hitch into position. Remove fishwire and loosely secure mounting hardware to hold the hitch into position.

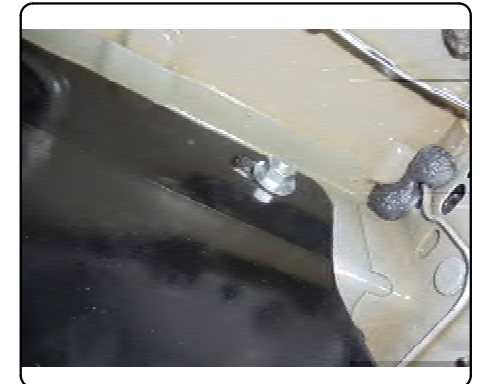

INSTALLATION WALKTHROUGH:

3. The passenger side plate will have limited access to secure fasteners. Use an 3/4" boxed end wrench to tighten hardware on this side.

The driver side plate can be secured using an 3/4" socket.

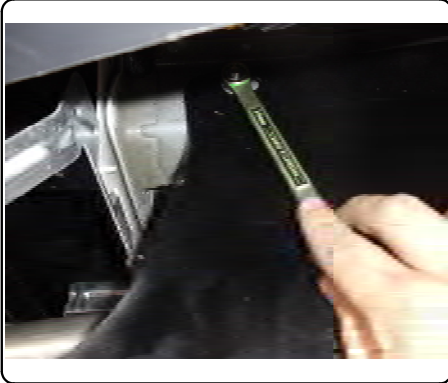

4. Torque all 1/2" fasteners to 110 ft-lbs.

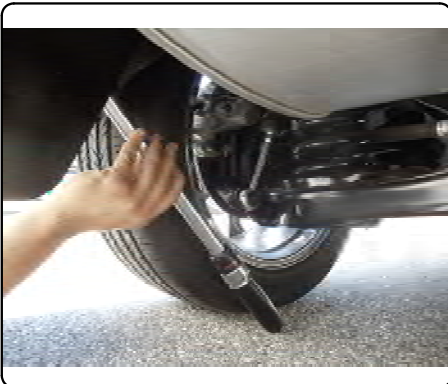

5. Installation is complete.



13131**FORD ESCAPE (EXCLUDING S MODEL)**

1/19/2016

GROSS LOAD CAPACITY WHEN USED AS A WEIGHT CARRYING HITCH: 3,500 LBS. TRAILER WEIGHT & 525 LBS. TONGUE WEIGHT.
 GROSS LOAD CAPACITY WHEN USED AS A WEIGHT DISTRIBUTION HITCH: 5,000 LBS. TRAILER WEIGHT & 525 LBS. TONGUE WEIGHT

DO NOT EXCEED VEHICLE MANUFACTURER'S RECOMMENDED TOWING CAPACITY.

HAVING INSTALLATION QUESTIONS? CALL TECHNICAL SUPPORT AT 1-800-798-0813

Parts List			
ITEM	QTY	PART NUMBER	DESCRIPTION
1	4	CM-SP10	.250 x 1.00 x 2.50" SQUARE HOLE SPACER
2	4	1/2-13 x 1 1/2, GR8	CARRIAGE BOLT
3	4	HFN 1213, GR8	HEX FLANGE NUT
4	4	1_2 FISHWIRE	1/2" FISHWIRE

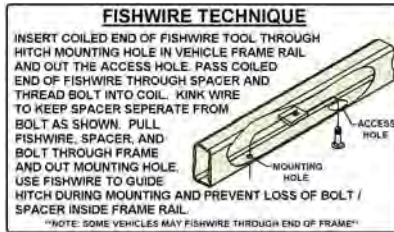

TOOLS REQUIRED
DIE GRINDER
RATCHET
SOCKET SET
3/4" BOXED END WRENCH
TORQUE WRENCH

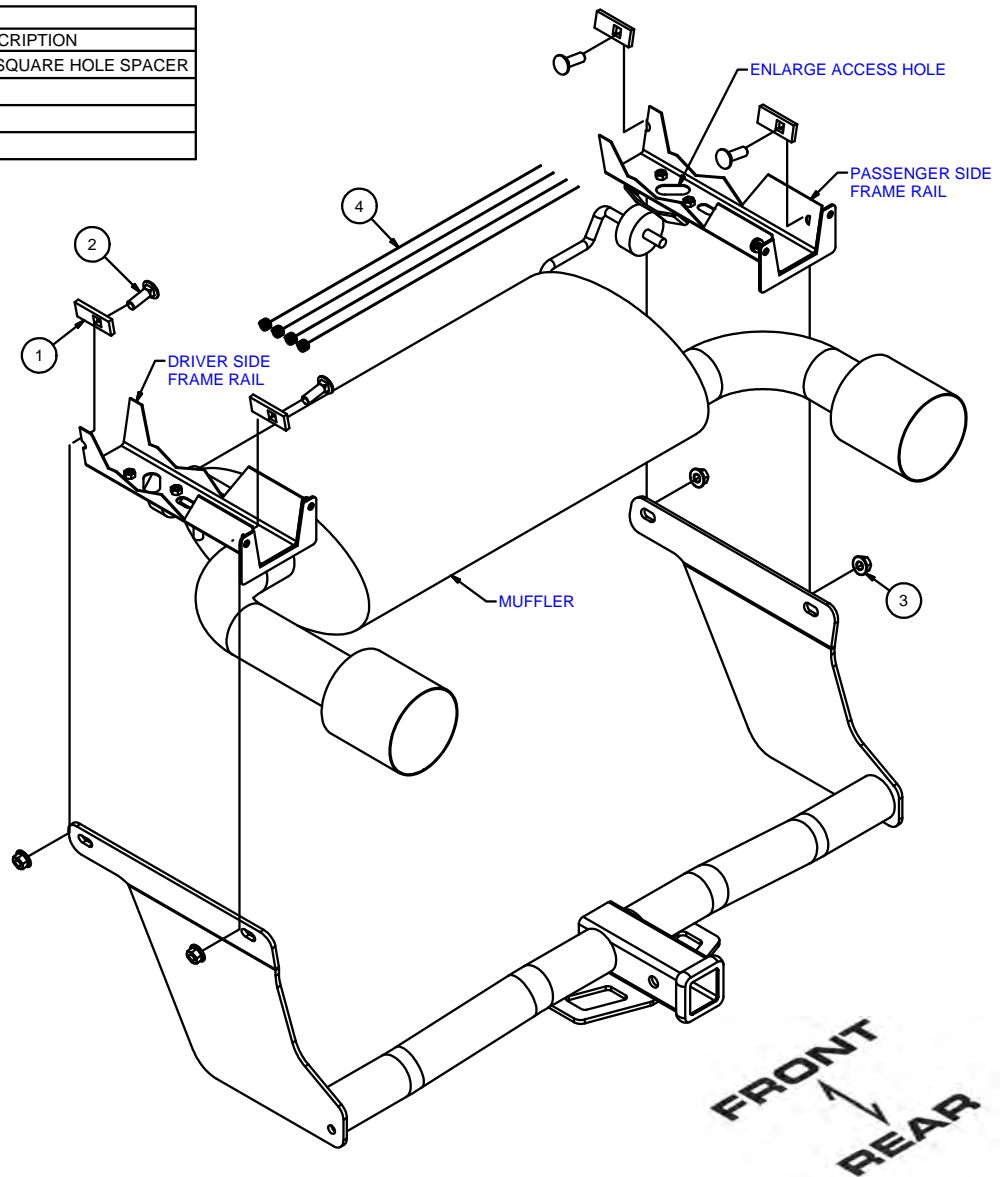

HITCH WEIGHT: 40 LBS.

INSTALL TIME

PROFESSIONAL: 20 MINUTES

NOVICE (DIY): 45 MINUTES

INSTALL NOTES:

FISHWIRING REQUIRED
 HOLE ENLARGEMENT REQUIRED

INSTALLATION STEPS

1. Enlarge access holes for square hole spacers with a die grinder. Fishwire 1/2" bolts and spacers into vehicle frame for the (2) side plate mounting points on each side of the vehicle.
2. Place hitch underneath vehicle and route fishwire through side plate mounting holes. It may be necessary to use two people to raise the hitch into position. Remove fishwire and loosely secure mounting hardware to hold the hitch into position.
3. The passenger side plate will have limited access to secure fasteners. Use an 3/4" boxed end wrench to tighten hardware on this side. The driver side plate can be secured using an 3/4" socket.
4. Torque all 1/2" fasteners to 110 ft-lbs.
5. Installation is complete.

PERIODICALLY CHECK THIS RECEIVER HITCH TO ENSURE THAT ALL FASTENERS ARE TIGHT AND THAT ALL STRUCTURAL COMPONENTS ARE SOUND.

Curt Manufacturing LLC., warrants this product to be free of defects in material and/or workmanship at the time of retail purchase by the original purchaser. If the product is found to be defective, Curt Manufacturing LLC., may repair or replace the product, at their option, when the product is returned, prepaid, with proof of purchase. Alteration to, misuse of, or improper installation of this product voids the warranty. Curt Manufacturing LLC.'s liability is limited to repair or replacement of products found to be defective, and specifically excludes liability for incidental or consequential loss or damage.