



Safety glasses should be worn at all times while installing this product.

YEARS: 09-PRESENT

MAKE: AUDI/PORSCHE

MODEL: Q5/MACAN (EXCLUDING HYBRID)

STYLE: SUV

**WARNING: NEVER EXCEED YOUR VEHICLE MANUFACTURER'S RECOMMENDED TOWING CAPACITY**

**WEIGHT CARRYING:**  
 TRAILER WEIGHT: 5000 LBS.  
 TONGUE WEIGHT: 750 LBS.

**WARNING:**  
 WE RECOMMEND THE USE OF 18050 STABILIZING STRAPS FOR ALL NON-TRAILER (WHEEL-LESS) LOADS. PLEASE SEE THE CURT CATALOG OR VISIT US ONLINE AT [WWW.CURTMFG.COM](http://WWW.CURTMFG.COM) FOR FURTHER INFORMATION.

**INSTALLATION TIME: 45-90 MIN.**

THE INSTALL TIME LISTED IS FOR PROFESSIONAL /NOVICE INSTALLERS. IF YOU ARE HESITANT TO UNDERTAKE THIS TASK ON YOUR OWN, CONTACT AN AUTHORIZED CURT INSTALLER FOR ADDITIONAL ASSISTANCE.

**INSTALLATION REQUIRES:**

SAFETY GLASSES	RATCHET	T-20 TORXBIT SOCKET
SCREW DRIVER	9/16\"/> 10mm 13mm SOCKET	T-27 TORXBIT SOCKET
12\"/> SOCKET EXTENSION	MARKER	POWER DRILL
DRILL BIT 1/2"	TORQUE WRENCH	CUT-OFF WHEEL  AVIATION SHEARS

**INSTALLATION TIPS:**

- BEFORE YOU BEGIN INSTALLATION, READ ALL INSTRUCTIONS THOROUGHLY.
- TO EASE INSTALLATION, 2 PEOPLE MAY BE REQUIRED.
- USING PROPER TOOLS WILL GREATLY IMPROVE THE QUALITY OF THE INSTALL AND REDUCE THE TIME REQUIRED.
- NEED HELP OR HAVE SOME QUESTIONS? CALL TECHNICAL SUPPORT AT 800.798.0813

**LEVEL OF DIFFICULTY: MODERATE**

EASY	MODERATE	CHALLENGING
	TEMPORARY PART REMOVAL REQUIRED	
	LOWER EXHAUST HANGERS	
	DRILLING REQUIRED ON PORSCHE MODELS ONLY	
	SILICONE / SEALANT ADVISED	
	TRIMMING REQUIRED ON PORSCHE MODELS ONLY	

**VEHICLE PHOTO:**



REPRESENTATIVE PHOTO

**HITCH ILLUSTRATION:**

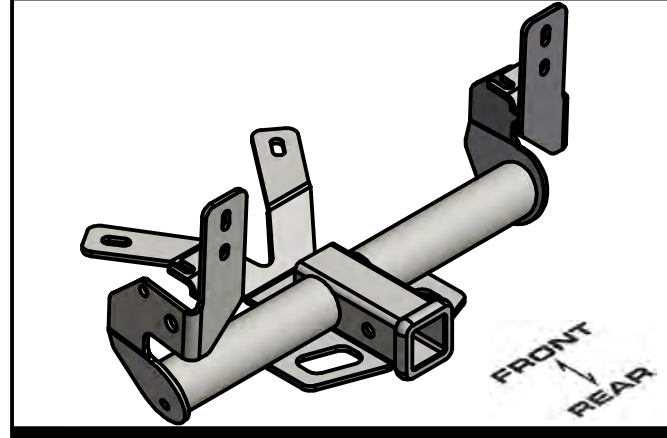

MAKE SURE YOUR HITCH MATCHES

**PERIODICALLY CHECK THIS RECEIVER HITCH TO ENSURE ALL FASTENERS ARE TIGHT AND ALL STRUCTURAL COMPONENTS ARE SOUND**

CURT Manufacturing LLC. warrants this product to be free of defects in material and/or workmanship at the time of retail purchase by the original purchaser. If the product is found to be defective, Curt Manufacturing LLC. may repair or replace the product at their option, when the product is returned, prepaid, with proof of purchase. Alteration to, misuse of, or improper installation of this product voids the warranty. Curt Manufacturing LLC.'s liability is limited to repair or replacement of products found to be defective, and specifically excludes liability for incidental or consequential loss or damage.

For more information log onto [www.curtmfg.com](http://www.curtmfg.com), & for helpful towing tips log onto [www.hitchinfo.com](http://www.hitchinfo.com)

INSTALLATION WALKTHROUGH:

Parts List			
ITEM	QTY	PART NUMBER	DESCRIPTION
1	2	HFN 1213, GR8	HEX FLANGE NUT
2	2	1/2-13 x 1 1/4, GR8	CARRIAGE BOLT
3	2	U-BOLT	3/8-16 x1.5x1 SQUARE U-BOLT
4	4	HFN3816	HEX FLANGE NUT
5	2	CM-SP17	.250 x 1.25 x 2.50" SQUARE SPACER
6	2	3_8 FISHWIRE	3/8" FISHWIRE

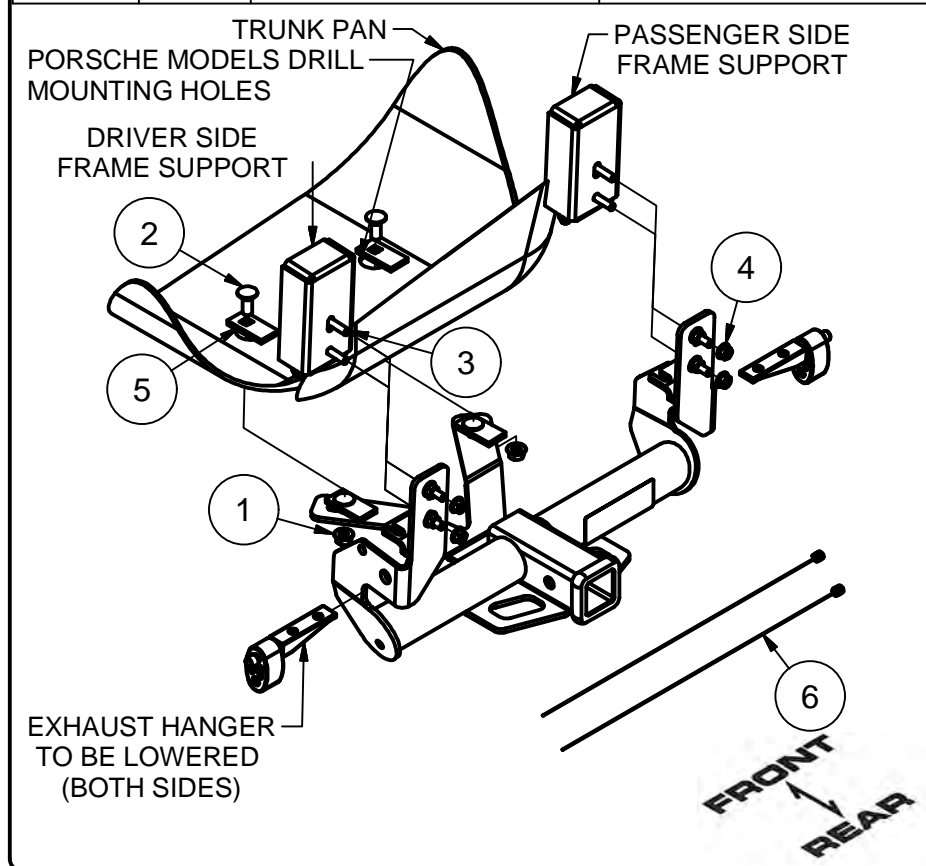

(READ ALL STEPS BEFORE BEGINNING INSTALLATION)

1. Remove the bumper fascia by removing (4) T-20 Torx bit screws (2) from the trunk (1) from each wheel well, and disconnect (1) snap tab on each side from the bumper to the support strap.

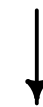
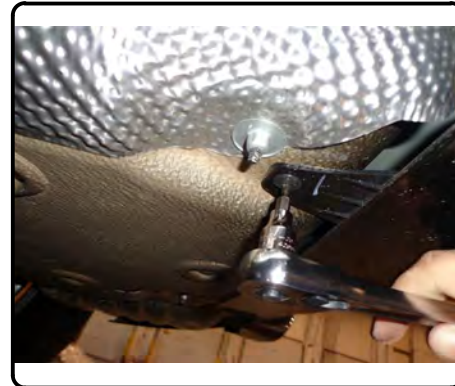

2. Remove lower bumper fascia by lightly pulling along the snap groove, which spans the length of the bumper and disconnect (4) sensor plugs if equipped. Set fascia aside for reassembly.

(Note: Audi Q5-S, SQ5 models require removal of entire fascia.)

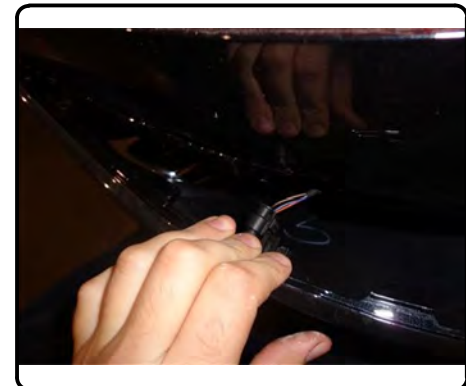
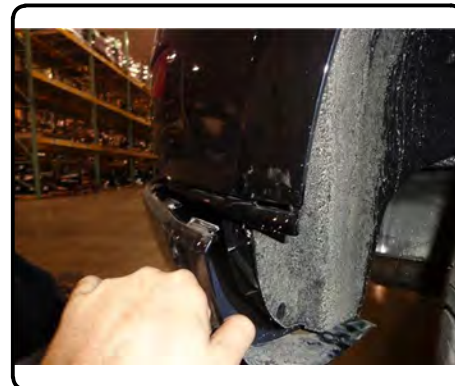

## INSTALLATION WALKTHROUGH:

3. Lower the exhaust hanger from each side of the vehicle frame by removing (2) 8mm bolts from each exhaust hanger bracket. Cut around the (2) trunk pan plugs and return to customer.  
**Porsche models:** Remove trunk pan cover by removing (4) nuts with a 10mm socket prior to cutting around the trunk pan plugs. Return cover to customer.

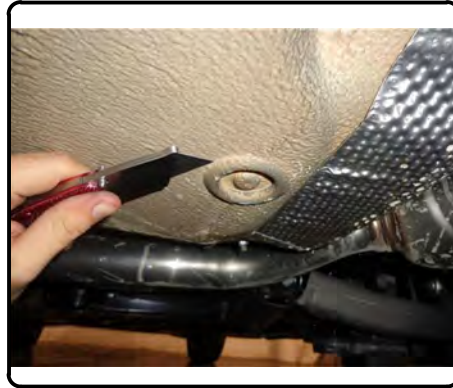

4. Install the u-bolts in the frame rail support as shown in Fig 1. Resecure the exhaust bracket each side, clamping the hitch mounting strap between the frame support and the hanger bracket by replacing the factory 8mm bolts.



5. **Porsche models:** The trunk pan mounting holes must be drilled. Open trunk to clear vehicle components for drilling. Remove floor panels and spare tire, set aside. Disconnect battery terminals with a 10mm socket, remove audio module by removing (2) T-27 Torx screws. Disconnect battery strap using a 13mm socket and extension.



6. **Porsche models (2009-2016):** With trunk components cleared for drilling, mark drill holes through hitch mounting holes on underside of pan. Drill 1/2" holes for mounting hardware. **NOTE: 2017 models do not require drilling.**

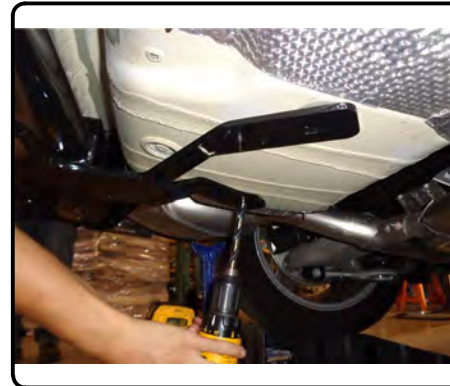

## INSTALLATION WALKTHROUGH:

7. Insert the 1/2" carriage bolt and spacer into the trunk pan holes. Apply caulk/sealant to the area between the trunk pan hole and hitch. Raise hitch into position and lightly secure with 1/2" hardware.

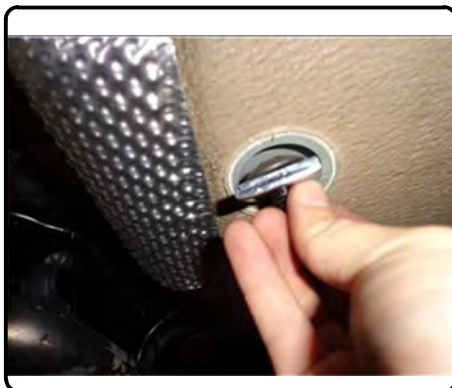

8. In sequence, torque 1/2" hardware to 110 lb-ft, 8mm bolts to 23 lb-ft, and 3/8" u-bolts to 45 lb-ft. Reinstall lower bumper fascia by following Steps 1-2 in reverse.  
**Porsche models:** Fascia must be trimmed before reassembly. Trunk components can be reinstalled at this time (Step 5 in reverse).

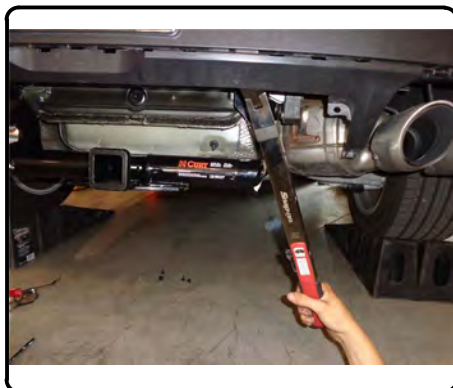
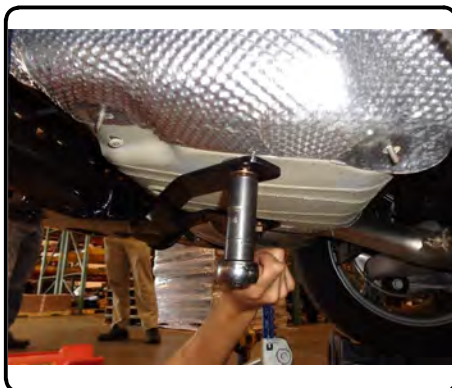

9. **Porsche models:** Raise rear fascia up into position and mark around side plate interference where fascia needs to be trimmed. Approx. 1/2" by 1" each side. Trim area with either a cut-off wheel or shears. After fit is confirmed, clip fascia back into position by following Steps 1-2 in reverse.



Installation complete

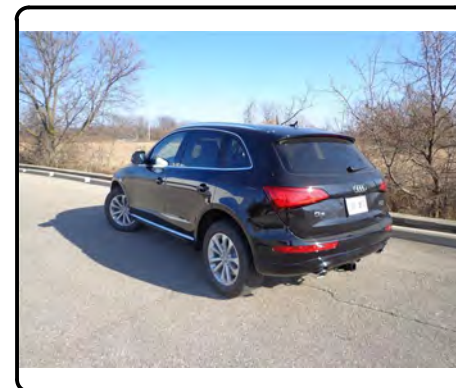
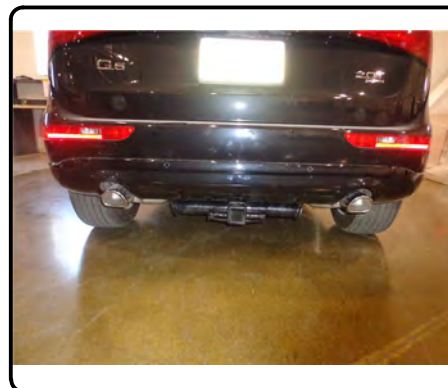

## TOWING SAFETY INFORMATION

### Gross Trailer Weight / GTW

The Gross Trailer Weight is the weight of the trailer & cargo. Measure this by putting the fully loaded trailer on a vehicle scale.



### Tongue Weight / TW

The downward force that is exerted on the hitch ball by the coupler. The tongue weight will vary depending on where the load is positioned in relationship to the trailer axle(s). To measure the tongue weight, use either a commercial scale or a bathroom scale with the coupler at towing height. When using a bathroom scale with heavier tongue weights, use the method shown and multiply the scale reading by 3.

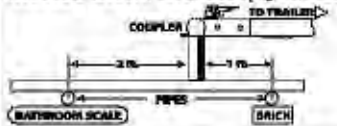

### Weight Carrying / WC

The total weight of both the trailer and the cargo inside. Never exceed the weight capacity of your trailer hitch.

### Weight Distribution / WD

Used to balance the weight of the cargo between the front and rear wheels throughout the trailer, allowing for better steering, braking, and level riding.

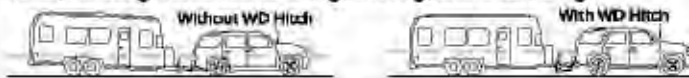

### Sway Control

A device used to reduce the lateral movements of the trailer that are caused by the wind. This works in conjunction with a weight distribution hitch. Do not use this on a class 1 or 2 hitch, or with surge brakes.

### How Much Can You Safely Tow?

TRAILER TYPE	TONGUE WEIGHT (lb.)									
	1100	1200	1300	1400	1500	1600	2100	2400	2700	3000
<b>Coupler</b>										
11c										
<b>Weight</b>										
11c	2100	2400	2700	3000	3300	3600	3900	4200	4500	4800
<b>Weight</b>										
11c	2800	3200	3600	4000	4400	4800	5200	5600	6000	6400
<b>5th Wheel</b>										
11c										

*Refer to owner's manual for towing capabilities and limitations.*

### Ball Mount

The ball mount is placed inside the opening of the receiver hitch which is mounted to the vehicle. Make sure a hitch pin and clip is properly securing the ball mount to the receiver hitch before you begin towing.

• A: Rise. B: Drop. C: Hole Size. D: Length.

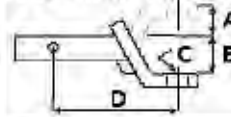

### Trailer Ball

The connection from the hitch to the trailer. There are many factors that determine the correct hitch ball:

- Number one is the hitch ball's gross trailer weight rating.
- The mounting platform must be at least 3/8" thick.
- The hole diameter must not be more than 1/16" larger than the threaded shank.
- Every time you tow, check the nut and lock washer to make sure they are fastened securely.
- A: Ball Dia. B: Shank Length. C: Shank Dia. D: Shank Rise.



### Coupler

The component that is placed over the trailer ball to connect the vehicle to the trailer. Be sure that the coupler size matches the size of the hitch ball and that the coupler handle is securely fastened. To determine what size hitch ball you need for your application you will need to know the size of coupler that is on the trailer. Be sure your coupler is properly adjusted to the ball you are using.

NOTE: For added security the use of safety devices such as Coupler Safety Pins and Locks is strongly recommended.

### Safety Chains

Safety chains are a requirement and should be crossed under the tongue of the trailer so that the tongue will not drop to the road if it becomes separated from the hitch. Always leave enough slack so you can turn. Never allow the safety chains to drag on the ground and never attach the chains to the bumper.

Trailer Classification: Safety Chain Breaking Force - Minimum

Class 1: 2,000 lbs. (8.9 kN)

Class 2: 3,500 lbs. (15.6 kN)

Class 3: 5,000 lbs. (22.2 kN)

The strength rating of each length of safety chain or its equivalent and its attachments shall be equal to or exceed in minimum breaking force the GVWR (Gross Vehicle Weight Rating) of the trailer.

### Electrical

Trailer lights, Electric Brakes, Break-away systems - Every time you tow, be sure to check that all components are working properly.

Wiring identification by color:

7-WAY						
6-WAY						7-WAY
5-WAY					6-WAY	
4-WAY				5-WAY		
GREEN	YELLOW	BROWN	WHITE	RED	BLUE	PURPLE
RIGHT TURN & BRAKE	LEFT TURN & BRAKE	TAILLIGHTS	GROUND	AUXILIARY POWER	ELECTRIC BRAKES	BACK-UP LIGHTS

CURT DISCLAIMER: WIRING COLOR SHOWN WORK IN CONJUNCTION WITH CURT MANUFACTURING PRODUCTS.

# 13136 AUDI Q5 & PORSCHE MACAN (EXCLUDING HYBRID)

11/14/2017

PAGE 1 of 2

GROSS LOAD CAPACITY WHEN USED AS A WEIGHT CARRYING HITCH: 5000 LBS. TRAILER WEIGHT & 750 LBS. TONGUE WEIGHT.

\*\*\*DO NOT EXCEED VEHICLE MANUFACTURER'S RECOMMENDED TOWING CAPACITY.\*\*\*

WARNING: ALL NON-TRAILER LOADS APPLIED TO THIS PRODUCT MUST BE SUPPORTED BY 18050 STABILIZING STRAPS.

\*\* FAILURE TO PROPERLY SUPPORT NON-TRAILER LOADS WILL VOID PRODUCT WARRANTY\*\*

HAVING INSTALLATION QUESTIONS? CALL TECHNICAL SUPPORT AT 1-800-798-0813

Parts List			
ITEM	QTY	PART NUMBER	DESCRIPTION
1	2	HFN 1213, GR8	HEX FLANGE NUT
2	2	1/2-13 x 1 1/4, GR8	CARRIAGE BOLT
3	2	U-BOLT	3/8-16 x1.5x1 SQUARE U-BOLT
4	4	HFN3816	HEX FLANGE NUT
5	2	CM-SP17	.250 x 1.25 x 2.50" SQUARE HOLE SPACER
6	2	3_8 FISHWIRE	3/8" FISHWIRE

REQUIRED FOR AUDI MODELS
TOOLS REQUIRED
T-20 TORX BIT
3/4" SOCKET
9/16" SOCKET
13mm SOCKET
RATCHET
TORQUE WRENCH

ADDITIONAL TOOLS REQUIRED FOR PORSCHE MODELS
TOOLS REQUIRED
FLATHEAD SCREWDRIVER
10mm SOCKET
T-27 TORX BIT
12" SOCKET EXTENSION
PAINT PEN/MARKER
POWER DRILL
1/2" DRILL BIT
CUT-OFF WHEEL/SHEARS

**RUBBER ISOLATOR REMOVAL DIAGRAM**

This technique can be used if an Exhaust Hanger Removal Pliers is not available.

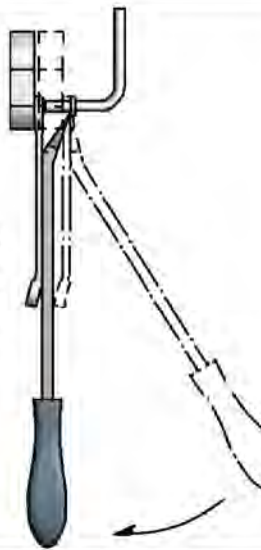

Using a 5/8" open end wrench, slide the wrench up to the rubber isolator, cradling the hanger rod as shown. Next place the flat edge of a pry bar between the wrench and the hanger stop or hanger rod. Then simply rotate the pry bar toward the wrench to remove the rubber isolator.

Note: Using a spray lubricant or soapy water on the hanger rod and the rubber isolator helps removal.

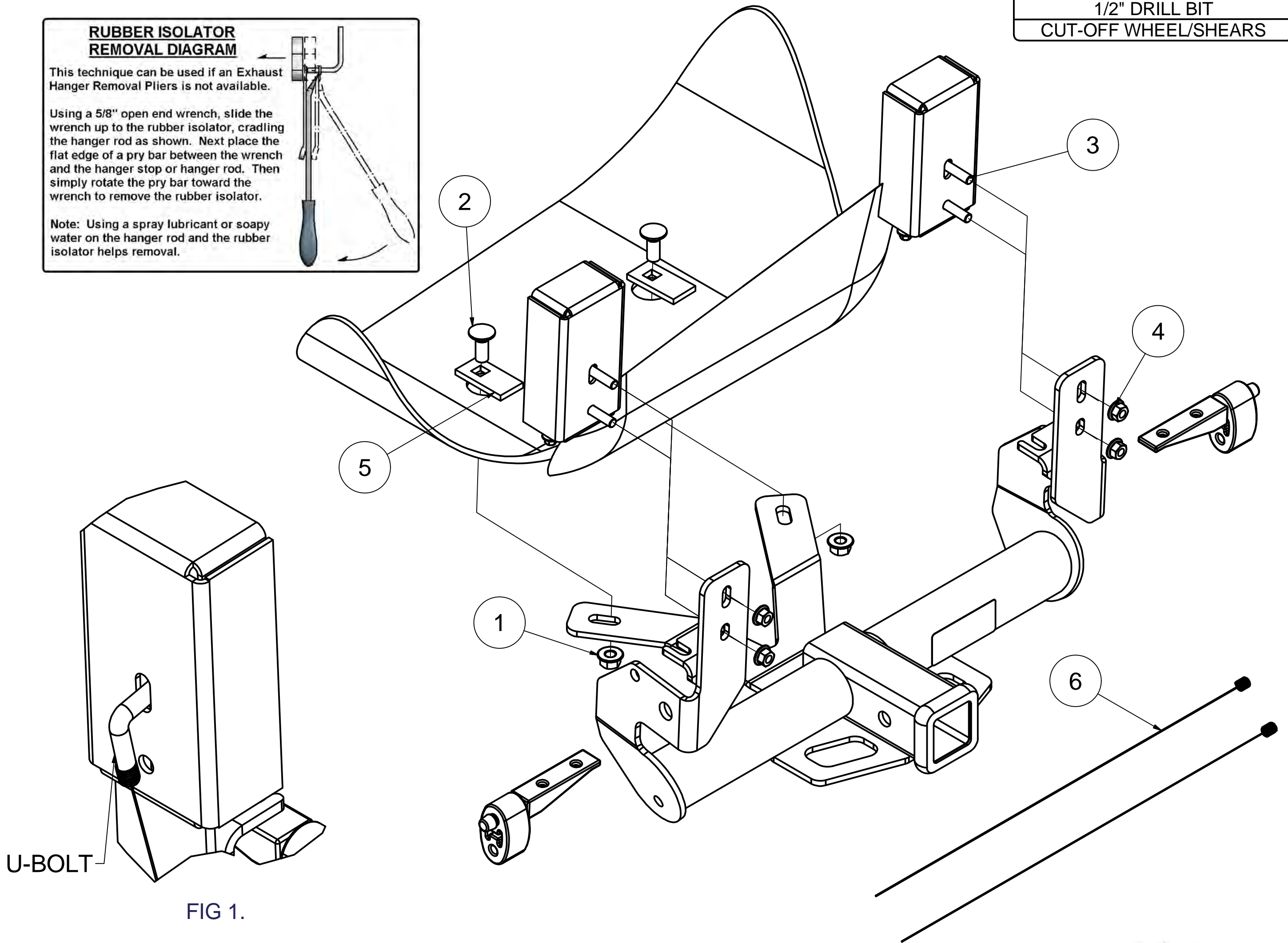

FIG 1.

HITCH WEIGHT: 25 LBS.

INSTALL TIME

PROFESSIONAL: 45 MINUTES

NOVICE (DIY): 90 MINUTES

INSTALL NOTES:

- SOME MODELS REQUIRE DRILLING
- SOME MODELS REQUIRE TRIMMING
- TEMPORARILY LOWER EXHAUST
- TEMPORARY PART REMOVAL

PERIODICALLY CHECK THIS RECEIVER HITCH TO ENSURE THAT ALL FASTENERS ARE TIGHT AND THAT ALL STRUCTURAL COMPONENTS ARE SOUND.

Curt Manufacturing LLC., warrants this product to be free of defects in material and/or workmanship at the time of retail purchase by the original purchaser. If the product is found to be defective, Curt Manufacturing LLC., may repair or replace the product, at their option, when the product is returned, prepaid, with proof of purchase. Alteration to, misuse of, or improper installation of this product voids the warranty. Curt Manufacturing LLC.'s liability is limited to repair or replacement of products found to be defective, and specifically excludes liability for incidental or consequential loss or damage.

**INSTALLATION STEPS** (READ ALL STEPS BEFORE BEGINNING INSTALLATION.)

1. Remove the bumper fascia by removing (4) T-20 Torx bit screws; (2) from the trunk (1) from each wheel well, and disconnect (1) snap tab on each side from the bumper to the support strap.
2. Remove lower bumper fascia by lightly pulling along the snap groove, which spans the length of the bumper and disconnect (4) sensor plugs if equipped. Set fascia aside for reassembly.  
**(Note:** Audi Q5-S, SQ5 models require removal of entire bumper fascia.)
3. Lower the exhaust hanger from each side of the vehicle frame support by removing (2) 8mm bolts from each exhaust hanger bracket. Cut around the (2) trunk pan plugs and return to customer.  
**Porsche models:** Remove trunk pan cover by removing (4) nuts with a 10mm socket prior to cutting around the trunk pan plugs. Return cover to customer.
4. Install the u-bolts in the frame rail support as shown in Fig 1. Resecure the exhaust bracket each side, clamping the hitch mounting strap between the frame support and the hanger bracket by replacing 8mm bolts.
5. **Porsche models:** The trunk pan mounting holes must be drilled. Open trunk to clear vehicle components for drilling. Remove floor panels and spare tire, set aside. Disconnect battery terminals with a 10mm socket, remove audio module by removing (2) T-27 Torx screws. Disconnect battery strap using a 13mm socket and extension.
6. **Porsche models (2015-2016):** With trunk components cleared for drilling, mark drill holes through hitch mounting holes on underside of pan. Drill 1/2" access for mounting hardware. **NOTE: 2017 models do not require drilling.**
7. Insert the 1/2" carriage bolt and spacer into the trunk pan holes. Apply caulk/sealant to the area between the trunk pan hole and hitch. Raise hitch into position and lightly secure with 1/2" hardware.
8. In sequence, torque 1/2" hardware to 110 lb-ft, 8mm bolts to 23 lb-ft, and 3/8" u-bolts to 45 lb-ft. Reinstall lower bumper fascia by following steps 1-2 in reverse.  
**Porsche models:** Fascia must be trimmed before reassembly. Trunk components can be reinstalled at this time (Step 5 in reverse).
9. **Porsche models:** Raise rear fascia up into position and mark around side plate interference where fascia needs to be trimmed. Approx. 1/2" x 1" each side. Trim area with either a cut-off wheel or shears.  
After fit is confirmed, clip fascia back into position by following Steps 1-2 in reverse.

PERIODICALLY CHECK THIS RECEIVER HITCH TO ENSURE THAT ALL FASTENERS ARE TIGHT AND THAT ALL STRUCTURAL COMPONENTS ARE SOUND.