

13147**SUBARU FORESTER**

7/11/2012

GROSS LOAD CAPACITY WHEN USED AS A WEIGHT CARRYING HITCH: 4,000 LBS. TRAILER WEIGHT & 400 LBS. TONGUE WEIGHT.

*****DO NOT EXCEED VEHICLE MANUFACTURER'S RECOMMENDED TOWING CAPACITY.*******WARNING: ALL NON-TRAILER LOADS APPLIED TO THIS PRODUCT MUST BE SUPPORTED BY AUXILIARY STABILIZING STRAPS.****** FAILURE TO PROPERLY SUPPORT NON-TRAILER LOADS WILL VOID PRODUCT WARRANTY****

HAVING INSTALLATION QUESTIONS? CALL TECHNICAL SUPPORT AT 1-800-798-0813

Parts List			
ITEM	QTY	PART NUMBER	DESCRIPTION
1	2	1_2 FISHWIRE	1/2" FISHWIRE
2	4	1/2-13 x 1 1/2	CARRIAGE BOLT
3	4	CM-SP10	.250 x 1.00 x 2.50" SQUARE HOLE SPACER
4	4	HFN 1213	HEX FLANGE NUT

TOOLS REQUIRED

FLAT SCREWDRIVER

DIE GRINDER W/ CARBIDE BIT
(OR ROUND FILE)

DRILL

17/32" DRILL BIT

RATCHET

3/4" SOCKET

10" EXTENSION

TORQUE WRENCH

FISHWIRE TECHNIQUE

INSERT COILED END OF FISHWIRE TOOL THROUGH HITCH MOUNTING HOLE IN VEHICLE FRAME RAIL AND OUT THE ACCESS HOLE. PASS COILED END OF FISHWIRE THROUGH SPACER AND THREAD BOLT INTO COIL. KINK WIRE TO KEEP SPACER SEPARATE FROM BOLT AS SHOWN. PULL FISHWIRE, SPACER, AND BOLT THROUGH FRAME AND OUT MOUNTING HOLE. USE FISHWIRE TO GUIDE HITCH DURING MOUNTING AND PREVENT LOSS OF BOLT / SPACER INSIDE FRAME RAIL.

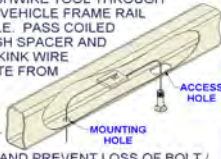

NOTE: SOME VEHICLES MAY FISHWIRE THROUGH END OF FRAME

REVERSE PULL FISHWIRE TECHNIQUE

ATTACH FISHWIRE TO CARRIAGE BOLT AND SLIDE SPACER ONTO FISHWIRE. PUSH THE BOLT THRU THE HOLE FOLLOWED BY THE SPACER (AS SHOWN). PULL BOLT BACK INTO POSITION, PROTRUDING FROM THE FRAME.

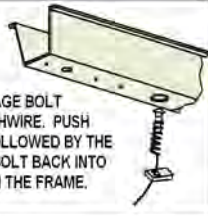

HITCH WEIGHT: 30 LBS.

INSTALL TIME

PROFESSIONAL: 30 MINUTES

NOVICE (DIY): 60 MINUTES

INSTALL NOTES:

- LOWER EXHAUST
- MODIFY / ENLARGE HOLES
- FISHWIRE HARDWARE

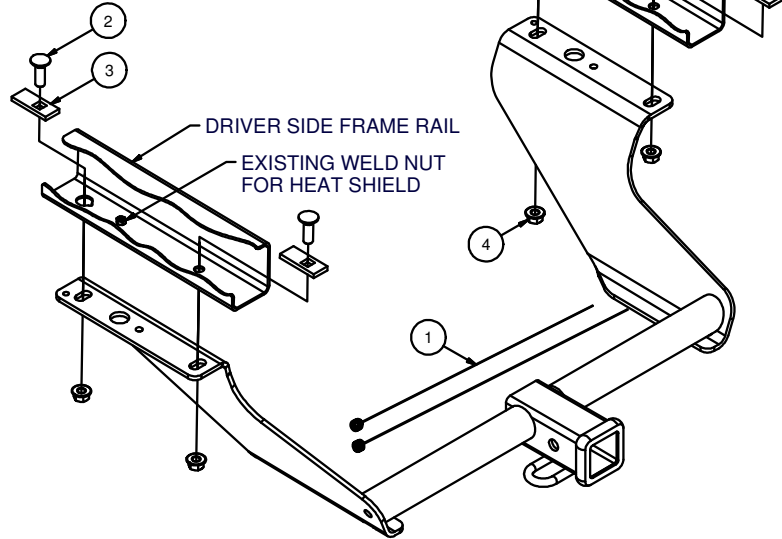
PASSENGER SIDE
FRAME RAIL

DRIVER SIDE FRAME RAIL

EXISTING WELD NUT
FOR HEAT SHIELD

REMOVE PLUG AND MODIFY USING DIE GRINDER (OR ROUND FILE) TO ALLOW INSERTION OF 1/2-13 BOLTS AND CM-SP10 SPACERS INTO FRAME RAIL

REMOVE PLUG AND ENLARGE HOLE USING 17/32" DRILL BIT TO ALLOW 1/2-13 BOLT THREADS TO PROTRUDE THROUGH FRAME RAIL

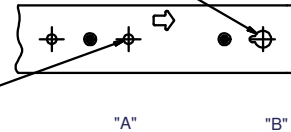
**HEAT SHIELD DIAGRAM**

(BOTH SIDES)

FRONT OF
VEHICLE**INSTALLATION STEPS**

- 1) Lower the exhaust for ease of install. (Remove (5) rubber hangers to lower the exhaust.)
NOTE: Use a spray lubricant or soapy water on the hanger rod and isolator to ease removal.
- 2) Using a screwdriver, remove the frame rail hole plugs. Enlarge / modify the holes as noted in the "Heat Shield Diagram".
- 3) Fishwire the 1/2-13 carriage bolts and the CM-SP10 spacers into hole ("A") as shown in the "Heat Shield Diagram". Refer to the "Fishwire Technique" diagram.
- 4) Reverse pull fishwire the 1/2-13 carriage bolts and the CM-SP10 spacers into hole ("B") as shown in the "Heat Shield Diagram". Refer to "Reverse Pull Fishwire Technique" diagram.
- 5) Raise the hitch into position and secure using the 1/2-13 hex flange nuts.
- 6) Torque all 1/2-13 fasteners to 110 lb-ft.
- 7) Re-install the exhaust and the rubber isolators removed in Step 1.

PERIODICALLY CHECK THIS RECEIVER HITCH TO ENSURE THAT ALL FASTENERS ARE TIGHT AND THAT ALL STRUCTURAL COMPONENTS ARE SOUND.

Curt Manufacturing Inc., warrants this product to be free of defects in material and/or workmanship at the time of retail purchase by the original purchaser. If the product is found to be defective, Curt Manufacturing Inc., may repair or replace the product, at their option, when the product is returned, prepaid, with proof of purchase. Alteration to, misuse of, or improper installation of this product voids the warranty. Curt Manufacturing Inc.'s liability is limited to repair or replacement of products found to be defective, and specifically excludes liability for incidental or consequential loss or damage.