

YEARS: 2014-PRESENT

MAKE: TOYOTA

MODEL: HIGHLANDER

STYLE: SUV

WARNING: NEVER EXCEED YOUR VEHICLE MANUFACTURER'S RECOMMENDED TOWING CAPACITY

WEIGHT CARRYING:
 TRAILER WEIGHT: 6,000 LBS.
 TONGUE WEIGHT: 900 LBS.

WEIGHT DISTRIBUTION:
 TRAILER WEIGHT: 8,000 LBS.
 TONGUE WEIGHT: 900 LBS.

PRO INSTALL TIME: 20 MIN.
NOVICE INSTALL TIME: 40 MIN.

IF YOU ARE HESITANT TO UNDERTAKE THIS TASK ON YOUR OWN, CONTACT AN AUTHORIZED CURT INSTALLER FOR ADDITIONAL ASSISTANCE.

INSTALLATION TIPS:

- BEFORE YOU BEGIN INSTALLATION, READ ALL INSTRUCTIONS THOROUGHLY.
- TO EASE INSTALLATION, 2 PEOPLE MAY BE REQUIRED.
- USING PROPER TOOLS WILL GREATLY IMPROVE THE QUALITY OF THE INSTALL AND REDUCE THE TIME REQUIRED.
- NEED HELP OR HAVE SOME QUESTIONS? CALL TECHNICAL SUPPORT AT 800.798.0813



INSTALLATION REQUIRES:

| | | |
|----------------------------|----------------------|--------------------|
| | | |
| RATCHET | TORQUE WRENCH | SOCKET |
| | | |
| 6" SOCKET EXTENSION | SCREW DRIVER | ROTARY TOOL |
| | | |
| SAFETY GLASSES | | |
| | | |
| | | |

LEVEL OF DIFFICULTY: MODERATE

| | | |
|-------------|----------------------------------|--------------------|
| EASY | MODERATE | CHALLENGING |
| | - NO DRILLING REQUIRED | |
| | - PART REMOVAL AND LOWER EXHAUST | |
| | - TRIM OR REMOVE UNDERBODY PANEL | |
| | | |
| | | |

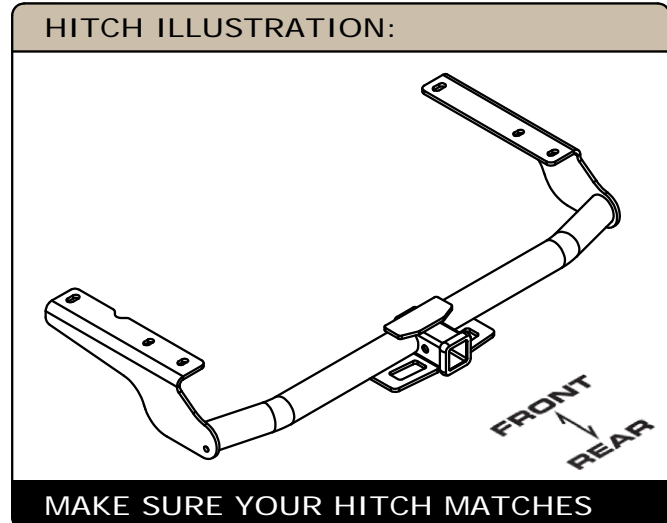

SCAN FOR MORE INFO

PERIODICALLY CHECK THIS RECEIVER HITCH TO ENSURE ALL FASTENERS ARE TIGHT AND ALL STRUCTURAL COMPONENTS ARE SOUND
 CURT Manufacturing LLC. warrants this product to be free of defects in material and/or workmanship at the time of retail purchase by the original purchaser. If the product is found to be defective, CURT Manufacturing LLC. may repair or replace the product at their option, when the product is returned, prepaid, with proof of purchase. Alteration to, misuse of, or improper installation of this product voids the warranty. CURT Manufacturing LLC.'s liability is limited to repair or replacement of products found to be defective, and specifically excludes liability for incidental or consequential loss or damage. For more information log onto www.curtmfg.com, & for helpful towing tips log onto www.hitchinfo.com

INSTALLATION WALKTHROUGH:

| Parts List | | | |
|------------|-----|-----------------|------------------------|
| ITEM | QTY | PART NUMBER | DESCRIPTION |
| 1 | 6 | M12-1.25 x 35mm | HEX BOLT |
| 2 | 6 | 1/2 | CONICAL TOOTHED WASHER |
| 3 | 2 | 5/16-18 x 1 | CARRIAGE BOLT |
| 4 | 2 | 5/16-18 | HEX FLANGE NUT |
| 5 | 1 | 13169-EB | .250" EXHAUST BRACKET |

ATTENTION: EXHAUST BRACKET **MUST** BE INSTALLED DURING ALL HITCH INSTALLATIONS

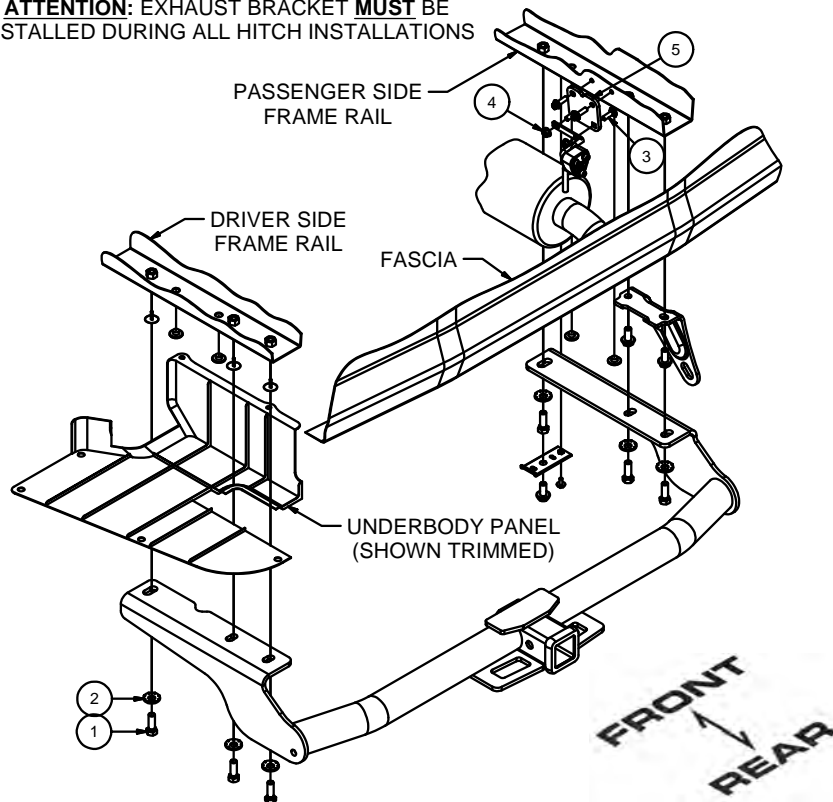

CONICAL TOOTHED WASHER ORIENTATION DIAGRAM

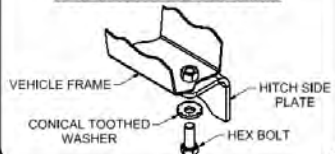

WELDNUT CLEANING

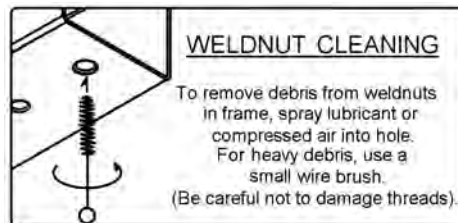

1. Remove the (7) fasteners securing the driver side underbody panel. After lowering the underbody panel return it to the owner or trim and reinstall in Step (5).

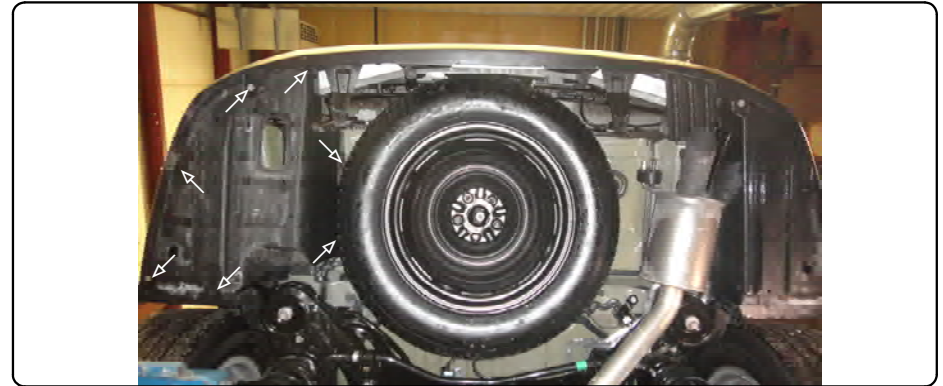

2. Remove the (4) rubber plugs from the frame rails and unscrew the (3) threaded plastic inserts from the driver side frame rail. Return plugs and inserts to owner.

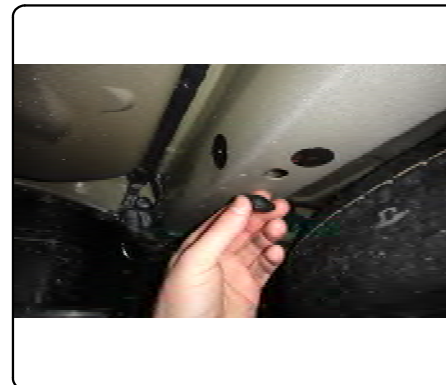

INSTALLATION WALKTHROUGH:

3. Remove the (3) M12 bolts securing the metal fascia tab and tow loop to the passenger side frame rail. Remove the (1) fascia screw and metal fascia tab from the passenger side underbody panel. Return the fascia tab, tow loop, and fasteners to owner.

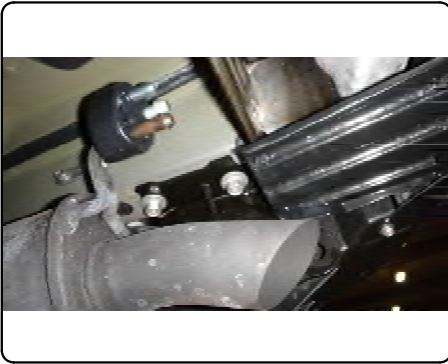

4. Remove and retain the (2) M8 bolts securing the exhaust hanger to the side of the passenger side frame rail. Raise the hitch over the exhaust and align the holes in the hitch with the weldnuts in the frame. Secure the hitch to the frame using the supplied M12-1.25 hex bolts and 1/2" conical toothed washers. Torque all 12mm hardware to 86 ft-lbs.



5. Secure the supplied exhaust bracket to the existing exhaust hanger using the supplied 5/16" carriage bolts and 5/16" hex flange nuts. Using the (2) M8 bolts removed in Step (4) secure the exhaust bracket to the existing weldnuts in the side of the frame rail. **Note:** The notch on the exhaust bracket must face up. Exhaust bracket must be installed during all hitch installations. Torque all 8mm and 5/16" hardware to 24 ft-lbs.



6. Mark and trim underbody panel. Reattach underbody panel using fasteners removed in Step (1). **Note:** See underbody panel trim diagram. Dimensions are approximate, confirm fit prior to trimming. Use ribs of the underbody panel as cutting guides.

INSTALLATION COMPLETE

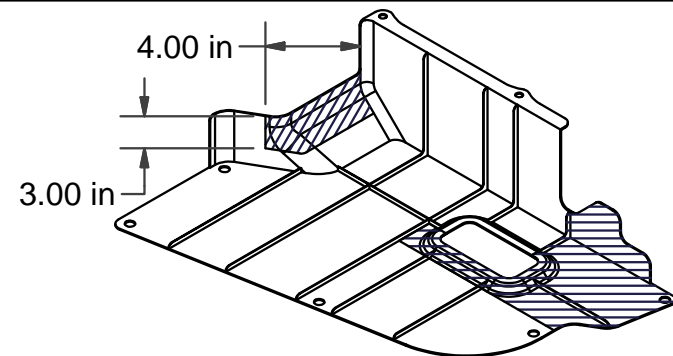

TOWING SAFETY INFORMATION

Gross Trailer Weight / GTW

The Gross Trailer Weight is the weight of the trailer & cargo. Measure this by putting the fully loaded trailer on a vehicle scale.



Tongue Weight / TW

The downward force that is exerted on the hitch ball by the coupler. The tongue weight will vary depending on where the load is positioned in relationship to the trailer axle(s). To measure the tongue weight, use either a commercial scale or a bathroom scale with the coupler at towing height. When using a bathroom scale with heavier tongue weights, use the method shown and multiply the scale reading by 3.

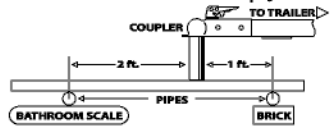

Weight Carrying / WC

The total weight of both the trailer and the cargo inside. Never exceed the weight capacity of your trailer hitch.

Weight Distribution / WD

Used to balance the weight of the cargo between the front and rear wheels throughout the trailer, allowing for better steering, braking, and level riding.



Sway Control

A device used to reduce the lateral movements of the trailer that are caused by the wind. This works in conjunction with a weight distribution hitch. Do not use this on a class 1 or 2 hitch, or with surge brakes.

How Much Can You Safely Tow?

| TONGUE WEIGHT (lb) | 1000 | 2000 | 3000 | 4000 | 5000 | 6000 | 7000 | 8000 | 10,000 | 12,000 |
|---|------|------|------|------|------|------|------|------|--------|--------|
| Tongue weight should be about 10 to 15 percent of the gross trailer weight. | | | | | | | | | | |
| CLASS 1 | | | | | | | | | | |
| CLASS 2 | | | | | | | | | | |
| CLASS 3 | | | | | | | | | | |
| CLASS 4 | | | | | | | | | | |
| CLASS 5 | | | | | | | | | | |
| TRAILER TYPE | | | | | | | | | | |
| Camper | 11' | 12' | 13' | 14' | 15' | 16' | | | | |
| lbs. | 1100 | 1200 | 1300 | 1400 | 1500 | 1600 | | | | |
| Vacation | 18' | 19' | 20' | 21' | 22' | 24' | 26' | 28' | 30' | 32' |
| lbs. | 2100 | 2400 | 2700 | 3000 | 3300 | 3600 | 3900 | 4200 | 4500 | 4800 |
| Vacation | 18' | 19' | 20' | 21' | 22' | 24' | 26' | 28' | 30' | 32' |
| lbs. | 2800 | 3200 | 3600 | 4000 | 4400 | 4800 | 5200 | 5600 | 6000 | 6400 |
| 5th Wheel | | | | | | | | | | |

Refer to owner's manual for towing capabilities and limitations.

Ball Mount

The ball mount is placed inside the opening of the receiver hitch which is mounted to the vehicle. Make sure a hitch pin and clip is properly securing the ball mount to the receiver hitch before you begin towing.

- A: Rise. B: Drop. C: Hole Size. D: Length.



Trailer Ball

The connection from the hitch to the trailer. There are many factors that determine the correct hitch ball:

- Number one is the hitch ball's gross trailer weight rating.
- The mounting platform must be at least 3/8" thick.
- The hole diameter must not be more than 1/16" larger than the threaded shank.
- Every time you tow, check the nut and lock washer to make sure they are fastened securely.
- A: Ball Dia. B: Shank Length. C: Shank Dia. D: Shank Rise.

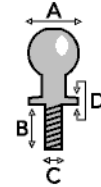

Coupler

The component that is placed over the trailer ball to connect the vehicle to the trailer. Be sure that the coupler size matches the size of the hitch ball and that the coupler handle is securely fastened. To determine what size hitch ball you need for your application you will need to know the size of coupler that is on the trailer. Be sure your coupler is properly adjusted to the ball you are using.

NOTE: For added security the use of safety devices such as Coupler Safety Pins and Locks is strongly recommended.

Safety Chains

Safety chains are a requirement and should be crossed under the tongue of the trailer so that the tongue will not drop to the road if it becomes separated from the hitch. Always leave enough slack so you can turn. Never allow the safety chains to drag on the ground and never attach the chains to the bumper.

Trailer Classification: Safety Chain Breaking Force - Minimum

Class 1: 2,000 lbs. (8.9 kN)

Class 2: 3,500 lbs. (15.6 kN)

Class 3: 5,000 lbs. (22.2 kN)

The strength rating of each length of safety chain or its equivalent and its attachments shall be equal to or exceed in minimum breaking force the GVWR (Gross Vehicle Weight Rating) of the trailer.

Electrical

Trailer lights, Electric Brakes, Break-away systems - Every time you tow, be sure to check that all components are working properly.

Wiring identification by color:

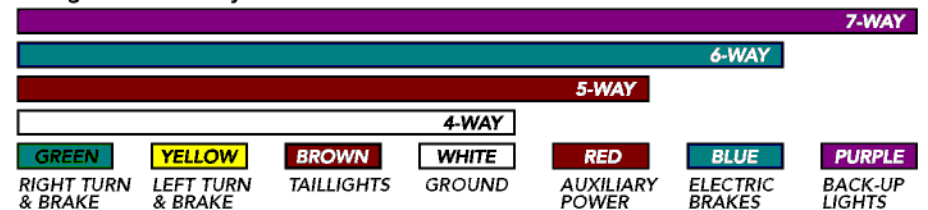

CURT DISCLAIMER: WIRING COLOR SHOWN WORK IN CONJUNCTION WITH CURT MANUFACTURING PRODUCTS.

13169

TOYOTA HIGHLANDER

4/17/2014

GROSS LOAD CAPACITY WHEN USED AS A WEIGHT CARRYING HITCH: 6,000 LBS. TRAILER WEIGHT & 900 LBS. TONGUE WEIGHT. GROSS LOAD CAPACITY WHEN USED AS A WEIGHT DISTRIBUTION HITCH: 8,000 LBS. TRAILER WEIGHT & 900 LBS. TONGUE WEIGHT

DO NOT EXCEED VEHICLE MANUFACTURER'S RECOMMENDED TOWING CAPACITY.

HAVING INSTALLATION QUESTIONS? CALL TECHNICAL SUPPORT AT 1-800-798-0813

| Parts List | | | |
|------------|-----|-----------------|------------------------|
| ITEM | QTY | PART NUMBER | DESCRIPTION |
| 1 | 6 | M12-1.25 x 35mm | HEX BOLT |
| 2 | 6 | 1/2 | CONICAL TOOTHED WASHER |
| 3 | 2 | 5/16-18 x 1 | CARRIAGE BOLT |
| 4 | 2 | 5/16-18 | HEX FLANGE NUT |
| 5 | 1 | 13169-EB | .250" EXHAUST BRACKET |

| TOOLS REQUIRED |
|------------------------|
| RATCHET |
| TORQUE WRENCH |
| 10mm SOCKET |
| 17mm SOCKET |
| 19mm SOCKET |
| 1/2" SOCKET |
| 6" EXTENSION |
| SCREW DRIVER |
| ROTARY TOOL (OPTIONAL) |
| SAFETY GLASSES |

ATTENTION: EXHAUST BRACKET MUST BE INSTALLED DURING ALL HITCH INSTALLATIONS

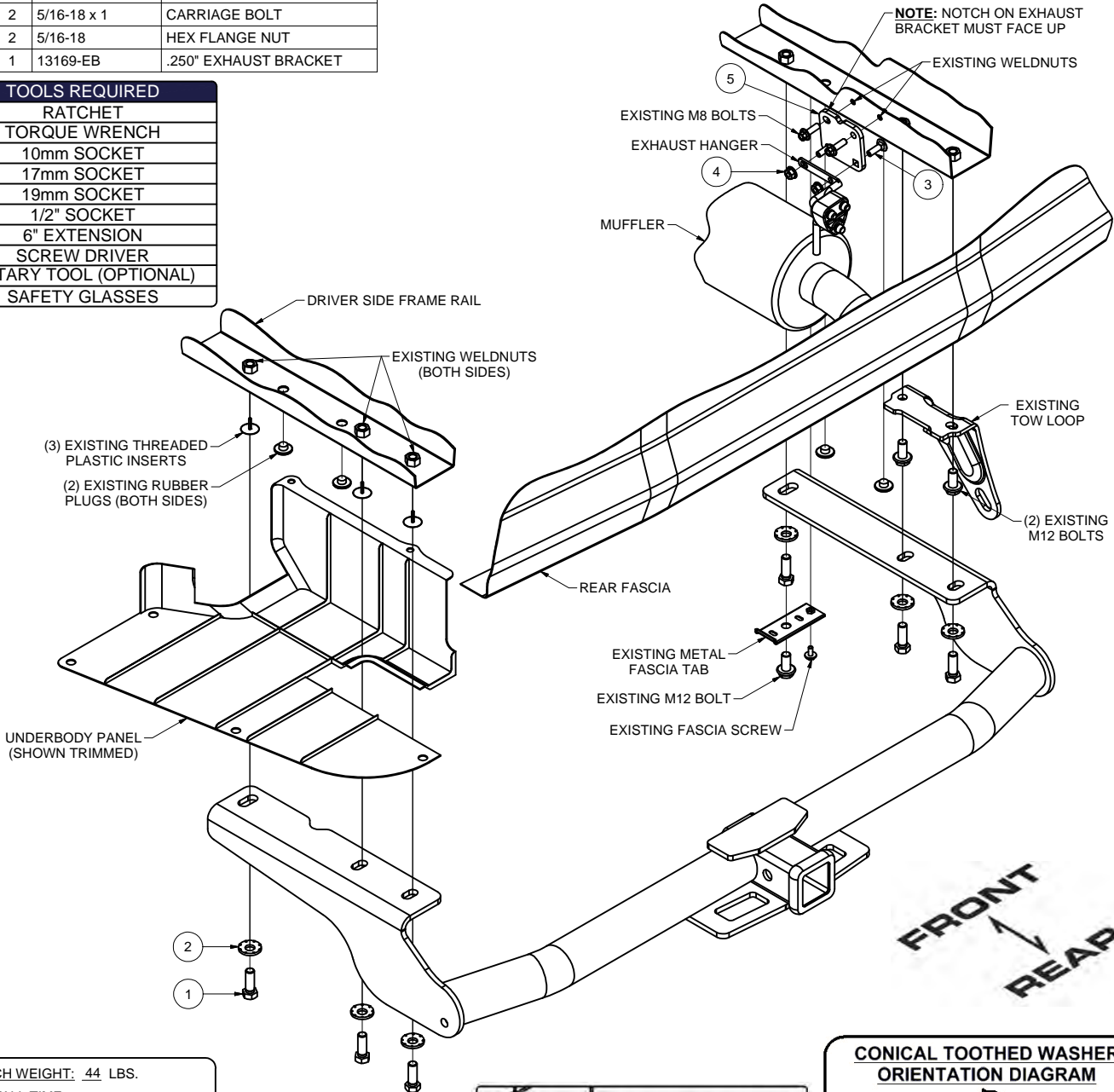

NOTE: NOTCH ON EXHAUST BRACKET MUST FACE UP

HITCH WEIGHT: 44 LBS.

INSTALL TIME

PROFESSIONAL: 20 MINUTES

NOVICE (DIY): 40 MINUTES

INSTALL NOTES:

- NO DRILLING
- PART REMOVAL
- LOWER EXHAUST
- TRIM OR REMOVE UNDERBODY PANEL

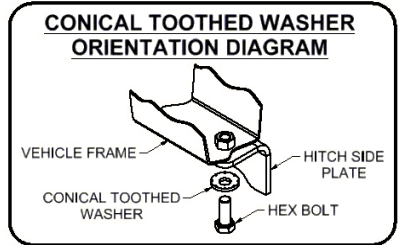
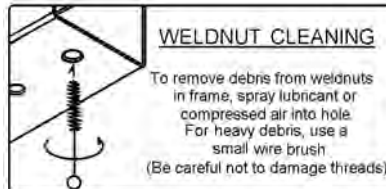

PERIODICALLY CHECK THIS RECEIVER HITCH TO ENSURE THAT ALL FASTENERS ARE TIGHT AND THAT ALL STRUCTURAL COMPONENTS ARE SOUND.

CURT Manufacturing LLC., warrants this product to be free of defects in material and/or workmanship at the time of retail purchase by the original purchaser. If the product is found to be defective, CURT Manufacturing LLC., may repair or replace the product, at their option, when the product is returned, prepaid, with proof of purchase. Alteration to, misuse of, or improper installation of this product voids the warranty. CURT Manufacturing LLC.'s liability is limited to repair or replacement of products found to be defective, and specifically excludes liability for incidental or consequential loss or damage.



Scan for more information

HAVING INSTALLATION QUESTIONS? CALL TECHNICAL SUPPORT AT 1-800-798-0813

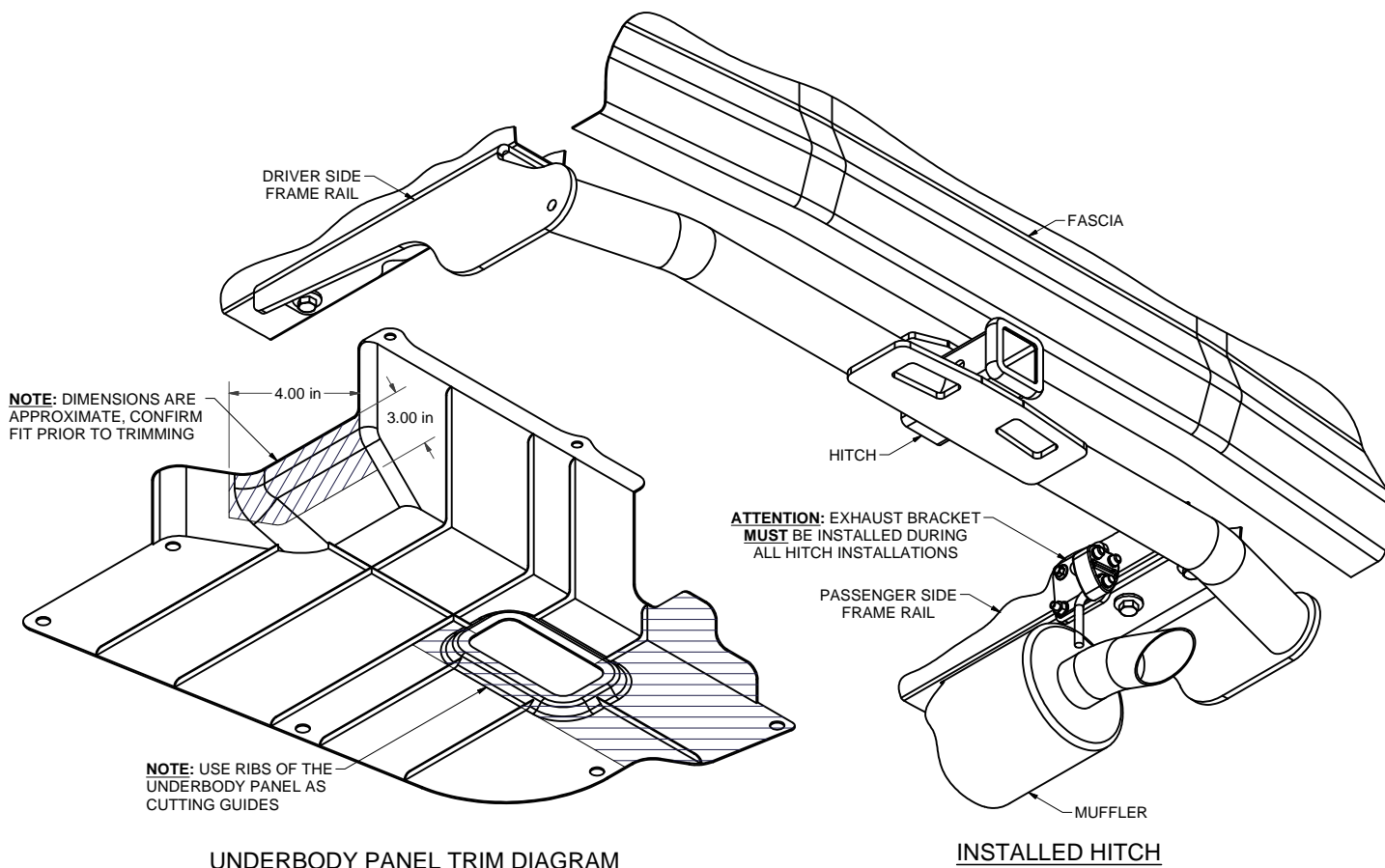

UNDERBODY PANEL TRIM DIAGRAM

INSTALLED HITCH

INSTALLATION STEPS

1. Remove the (7) fasteners securing the driver side underbody panel. After lowering the underbody panel return it to the owner or trim and reinstall in Step (6).
2. Remove the (4) rubber plugs from the frame rails and unscrew the (3) threaded plastic inserts from the driver side frame rail. Return plugs and inserts to owner.
3. Remove the (3) M12 bolts securing the metal fascia tab and tow loop to the passenger side frame rail. Remove the (1) fascia screw and metal fascia tab from the passenger side underbody panel. Return the fascia tab, tow loop, and fasteners to owner.
4. Remove and retain the (2) M8 bolts securing the exhaust hanger to the side of the passenger side frame rail.
5. Raise the hitch over the exhaust and align the holes in the hitch with the weldnuts in the frame. Secure the hitch to the frame using the supplied M12-1.25 hex bolts and 1/2" conical toothed washers.
6. Torque all 12mm hardware to 86 ft-lbs.
7. Secure the supplied exhaust bracket to the existing exhaust hanger using the supplied 5/16" carriage bolts and 5/16" hex flange nuts. **Note:** The notch on exhaust bracket must face up. Exhaust bracket must be installed during all hitch installations.
8. Using the (2) M8 bolts removed in Step (4) secure the exhaust bracket to the existing weldnuts in the side of the frame rail.
9. Torque all 8mm and 5/16" hardware to 24 ft-lbs.
10. Mark and trim underbody panel. Reattach underbody panel using fasteners removed in Step (1). **Note:** See underbody panel trim diagram. Dimensions are approximate, confirm fit prior to trimming. Use ribs of the underbody panel as cutting guides.

PERIODICALLY CHECK THIS RECEIVER HITCH TO ENSURE THAT ALL FASTENERS ARE TIGHT AND THAT ALL STRUCTURAL COMPONENTS ARE SOUND.

CURT Manufacturing LLC., warrants this product to be free of defects in material and/or workmanship at the time of retail purchase by the original purchaser. If the product is found to be defective, CURT Manufacturing LLC., may repair or replace the product, at their option, when the product is returned, prepaid, with proof of purchase. Alteration to, misuse of, or improper installation of this product voids the warranty. CURT Manufacturing LLC.'s liability is limited to repair or replacement of products found to be defective, and specifically excludes liability for incidental or consequential loss or damage.