

13180 / 78198 / RRH13180**00-06 TOYOTA TUNDRA PICKUP**

7/18/2012

EXCLUDES TOWABLE BUMPER MODELS

GROSS LOAD CAPACITY WHEN USED AS A WEIGHT CARRYING HITCH: 6,000 LBS. TRAILER WEIGHT & 600 LBS. TONGUE WEIGHT.
 GROSS LOAD CAPACITY WHEN USED AS A WEIGHT DISTRIBUTION HITCH: 10,000 LBS. TRAILER WEIGHT & 1,000 LBS. TONGUE WEIGHT

*****DO NOT EXCEED VEHICLE MANUFACTURER'S RECOMMENDED TOWING CAPACITY.*****

Parts List			
ITEM	QTY	PART NUMBER	DESCRIPTION
1	2	1/2"	LOCK WASHER
2	2	M12 - 1.25 x 40 HEX	HEX BOLT
3	2	1/2 - 13 x 2 1/2	HEX BOLT
4	4	FW12	FW, 12, ZP
5	2	CM-SP1	.250 x 1.50 x 2.00" SQUARE HOLE SPACER
6	2	1/2 - 13 x 2"	CARRIAGE BOLT
7	4	HFN 1213	HEX FLANGE NUT

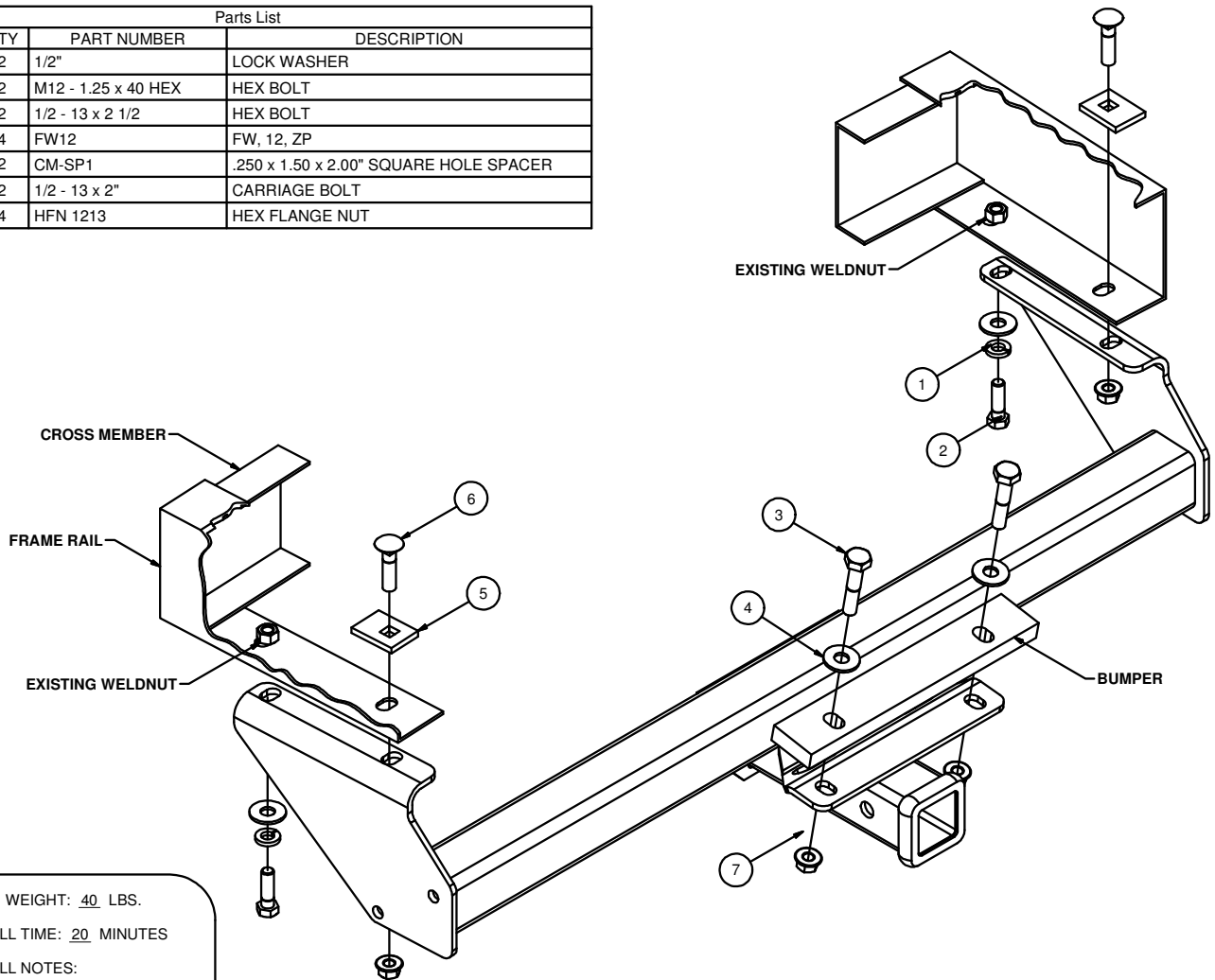

HITCH WEIGHT: 40 LBS.

INSTALL TIME: 20 MINUTES

INSTALL NOTES:

NO DRILLING REQUIRED**INSTALLATION STEPS**

- 1) Remove two fascia cups on bumper and return to owner.
- 2) Raise hitch into position.
- 3) Install 2, 12mm X 40mm fine thread bolts. (hand tighten)
- 4) Install 2, 1/2" hex bolts with washers into bumper and tighten.
- 5) Install 2, 1/2" carriage bolts with square hole spacer and hex flange nut.
- 6) Torque all fasteners to 110 lb-ft.

PERIODICALLY CHECK THIS RECEIVER HITCH TO ENSURE THAT ALL FASTENERS ARE TIGHT AND THAT ALL STRUCTURAL COMPONENTS ARE SOUND.

Curt Manufacturing Inc., warrants this product to be free of defects in material and/or workmanship at the time of retail purchase by the original purchaser. If the product is found to be defective, Curt Manufacturing Inc., may repair or replace the product, at their option, when the product is returned, prepaid, with proof of purchase. Alteration to, misuse of, or improper installation of this product voids the warranty. Curt Manufacturing Inc.'s liability is limited to repair or replacement of products found to be defective, and specifically excludes liability for incidental or consequential loss or damage.