



Safety glasses should be worn at all times while installing this product.

YEARS: 2011-CURRENT

MAKE: DODGE, JEEP

MODEL: DURANGO, GRAND CHEROKEE

STYLE: SUV

WARNING: NEVER EXCEED YOUR VEHICLE MANUFACTURER'S RECOMMENDED TOWING CAPACITY

WEIGHT CARRYING:
 TRAILER WEIGHT: 6,000 LBS.
 TONGUE WEIGHT: 600 LBS.

WEIGHT DISTRIBUTION:
 TRAILER WEIGHT: 7,500 LBS.
 TONGUE WEIGHT: 750 LBS.

PRO INSTALL TIME: 10-30 MIN.
NOVICE INSTALL TIME: 20-60 MIN.

IF YOU ARE HESITANT TO UNDERTAKE THIS TASK ON YOUR OWN, CONTACT AN AUTHORIZED CURT INSTALLER FOR ADDITIONAL ASSISTANCE.



INSTALLATION REQUIRES:

 RATCHET	 21mm 13mm SOCKET	 TORQUE WRENCH
 UTILITY KNIFE	 SAFETY GLASSES	

INSTALLATION TIPS:

- BEFORE YOU BEGIN INSTALLATION, READ ALL INSTRUCTIONS THOROUGHLY.
- TO EASE INSTALLATION, 2 PEOPLE MAY BE REQUIRED.
- USING PROPER TOOLS WILL GREATLY IMPROVE THE QUALITY OF THE INSTALL AND REDUCE THE TIME REQUIRED.
- NEED HELP OR HAVE SOME QUESTIONS? CALL TECHNICAL SUPPORT AT 800.798.0813

LEVEL OF DIFFICULTY: EASY

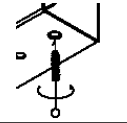
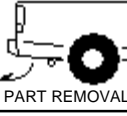
EASY	MODERATE	CHALLENGING
	NO DRILLING REQUIRED	
	TRIMMING OF EXCESS CAULK MAY BE REQUIRED	
	WELDNUT CLEANING MAY BE REQUIRED	
	DIESEL MODELS REQUIRE DEF TANK LOWERING	

VEHICLE PHOTO:



REPRESENTATIVE PHOTO

HITCH ILLUSTRATION:

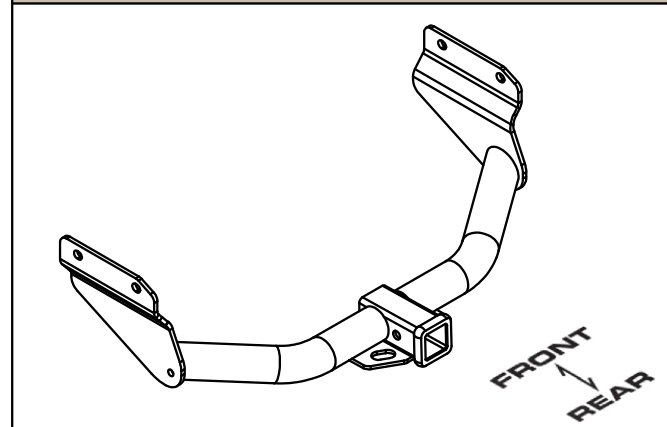

MAKE SURE YOUR HITCH MATCHES



SCAN FOR MORE INFO

PERIODICALLY CHECK THIS RECEIVER HITCH TO ENSURE ALL FASTENERS ARE TIGHT AND ALL STRUCTURAL COMPONENTS ARE SOUND
 CURT Manufacturing LLC. warrants this product to be free of defects in material and/or workmanship at the time of retail purchase by the original purchaser. If the product is found to be defective, CURT Manufacturing LLC. may repair or replace the product at their option, when the product is returned, prepaid, with proof of purchase. Alteration to, misuse of, or improper installation of this product voids the warranty. CURT Manufacturing LLC.'s liability is limited to repair or replacement of products found to be defective, and specifically excludes liability for incidental or consequential loss or damage. For more information log onto www.curtmfg.com, & for helpful towing tips log onto www.hitchinfo.com

INSTALLATION WALKTHROUGH:

Diesel models only:

Due to the Diesel Exhaust Fluid (DEF) Tank location, it will need to be lowered to access the passenger side bolts. **It is highly recommended that the tank is well supported before removing the fasteners as the tank may weigh as much as 80 lbs.**

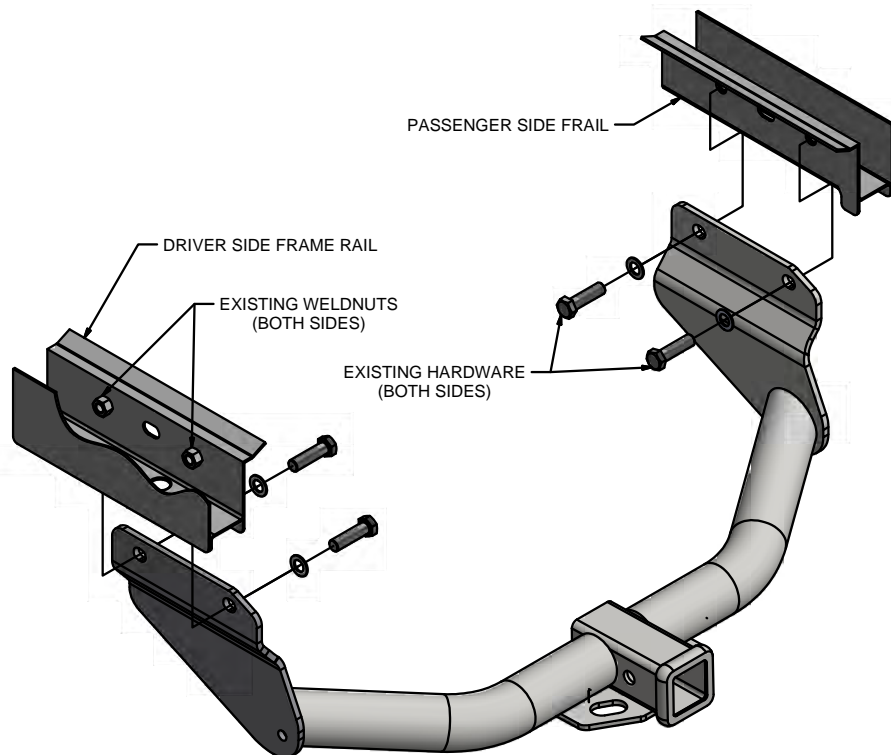

WELDNUT CLEANING

To remove debris from weldnuts in frame, spray lubricant or compressed air into hole. For heavy debris, use a small wire brush. (Be careful not to damage threads).

FRONT
↓
REAR

1. Lower the (DEF) tank by unclipping the electrical connection on the passenger side and sliding the clips off of the rear studs holding the tank.
2. Using a 13mm socket, remove the (2) rear stud posts and the (2) forward hex bolts from the tank. (See photo below) **DO NOT REMOVE FILLER PIPE FROM THE TANK.** The tank should be free to rotate slightly downward on the passenger side for access to the bolts/weld nuts.

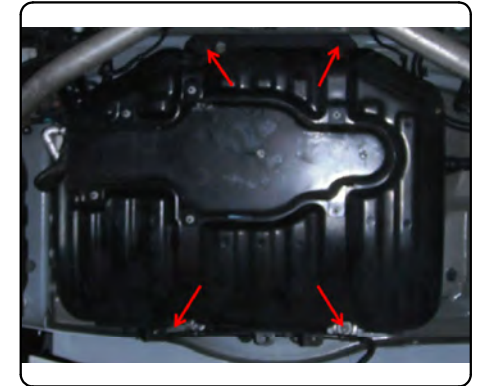

3. Remove existing M14 bolts. There will be (4) or (6) bolts depending on vehicle model. Retain (4) bolts for hitch installation. Return remaining bolts (if any) to vehicle owner.

Note: If factory tow loop is present you will need to remove it prior to install. Trim excess caulk on vehicle frame rails if it interferes with hitch installation.

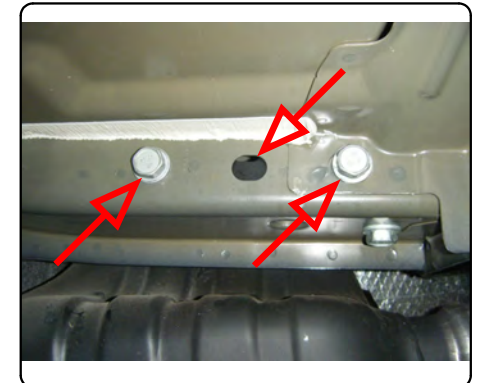

INSTALLATION WALKTHROUGH:

4. Raise hitch into position and reinstall (4) M14 bolts.
5. Tighten all M14 hardware to 126 ft-lbs.



6. Reinstall DEF tank if lowered on diesel models and reconnect electrical components. Torque DEF tank studs to 21 lb-ft and the DEF tank Hex Bolts to 24 lb-ft.

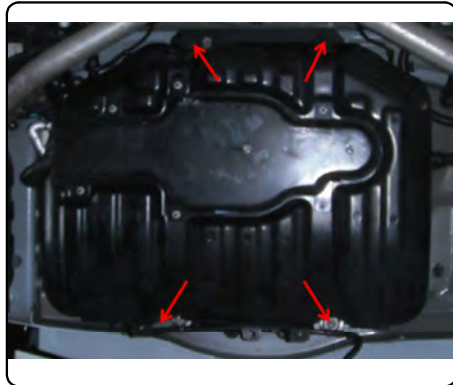

TOWING SAFETY INFORMATION

Gross Trailer Weight / GTW

The Gross Trailer Weight is the weight of the trailer & cargo. Measure this by putting the fully loaded trailer on a vehicle scale.

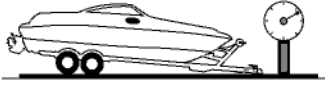

Tongue Weight / TW

The downward force that is exerted on the hitch ball by the coupler. The tongue weight will vary depending on where the load is positioned in relationship to the trailer axle(s). To measure the tongue weight, use either a commercial scale or a bathroom scale with the coupler at towing height. When using a bathroom scale with heavier tongue weights, use the method shown and multiply the scale reading by 3.

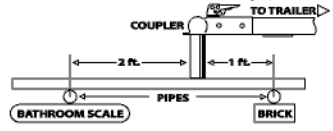

Weight Carrying / WC

The total weight of both the trailer and the cargo inside. Never exceed the weight capacity of your trailer hitch.

Weight Distribution / WD

Used to balance the weight of the cargo between the front and rear wheels throughout the trailer, allowing for better steering, braking, and level riding.



Sway Control

A device used to reduce the lateral movements of the trailer that are caused by the wind. This works in conjunction with a weight distribution hitch. Do not use this on a class 1 or 2 hitch, or with surge brakes.

How Much Can You Safely Tow?

TONGUE WEIGHT lbs	1000	2000	3000	4000	5000	6000	7000	8000	10,000	12,000
CLASS 1	[Bar]									
CLASS 2	[Bar]									
CLASS 3	[Bar]									
CLASS 4	[Bar]									
CLASS 5	[Bar]									
TRAILER TYPE										
Camper	11'	12'	13'	14'	15'	16'				
lbs	1100	1200	1300	1400	1500	1600				
Vacation	14'	16'	18'	20'	22'	24'	26'	28'	30'	32'
lbs	2100	2400	2700	3000	3300	3600	3900	4200	4500	4800
Vacation	14'	16'	18'	20'	22'	24'	26'	28'	30'	32'
lbs	2800	3200	3600	4000	4400	4800	5200	5600	6000	6400
5th Wheel										

Refer to owner's manual for towing capabilities and limitations.

Ball Mount

The ball mount is placed inside the opening of the receiver hitch which is mounted to the vehicle. Make sure a hitch pin and clip is properly securing the ball mount to the receiver hitch before you begin towing.

- A: Rise. B: Drop. C: Hole Size. D: Length.

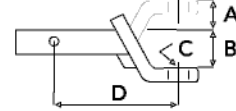

Trailer Ball

The connection from the hitch to the trailer. There are many factors that determine the correct hitch ball:

- Number one is the hitch ball's gross trailer weight rating.
- The mounting platform must be at least 3/8" thick.
- The hole diameter must not be more than 1/16" larger than the threaded shank.
- Every time you tow, check the nut and lock washer to make sure they are fastened securely.
- A: Ball Dia. B: Shank Length. C: Shank Dia. D: Shank Rise.

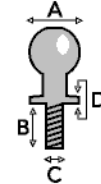

Coupler

The component that is placed over the trailer ball to connect the vehicle to the trailer. Be sure that the coupler size matches the size of the hitch ball and that the coupler handle is securely fastened. To determine what size hitch ball you need for your application you will need to know the size of coupler that is on the trailer. Be sure your coupler is properly adjusted to the ball you are using.

NOTE: For added security the use of safety devices such as Coupler Safety Pins and Locks is strongly recommended.

Safety Chains

Safety chains are a requirement and should be crossed under the tongue of the trailer so that the tongue will not drop to the road if it becomes separated from the hitch. Always leave enough slack so you can turn. Never allow the safety chains to drag on the ground and never attach the chains to the bumper.

Trailer Classification: Safety Chain Breaking Force - Minimum

Class 1: 2,000 lbs. (8.9 kN)

Class 2: 3,500 lbs. (15.6 kN)

Class 3: 5,000 lbs. (22.2 kN)

The strength rating of each length of safety chain or its equivalent and its attachments shall be equal to or exceed in minimum breaking force the GVWR (Gross Vehicle Weight Rating) of the trailer.

Electrical

Trailer lights, Electric Brakes, Break-away systems - Every time you tow, be sure to check that all components are working properly.

Wiring identification by color:

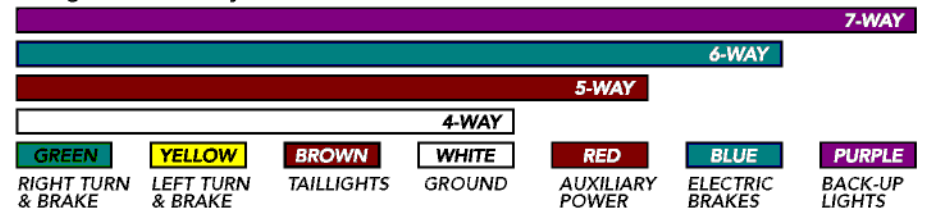

CURT DISCLAIMER: WIRING COLOR SHOWN WORK IN CONJUNCTION WITH CURT MANUFACTURING PRODUCTS.

13182

DODGE DURANGO, JEEP GRAND CHEROKEE

4/11/2017

GROSS LOAD CAPACITY WHEN USED AS A WEIGHT CARRYING HITCH: 6,000 LBS. TRAILER WEIGHT & 600 LBS. TONGUE WEIGHT.
 GROSS LOAD CAPACITY WHEN USED AS A WEIGHT DISTRIBUTION HITCH: 7,500 LBS. TRAILER WEIGHT & 750 LBS. TONGUE WEIGHT

DO NOT EXCEED VEHICLE MANUFACTURER'S RECOMMENDED TOWING CAPACITY.

HAVING INSTALLATION QUESTIONS? CALL TECHNICAL SUPPORT AT 1-800-798-0813

INSTALLED HITCH POSITION

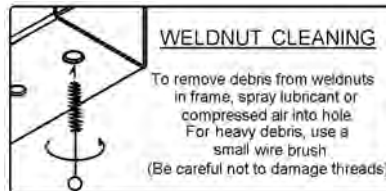
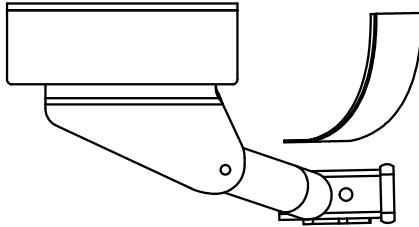

TOOLS REQUIRED

RATCHET
21mm SOCKET
TORQUE WRENCH
UTILITY KNIFE

Diesel (DEF) Tank Fastener Locations

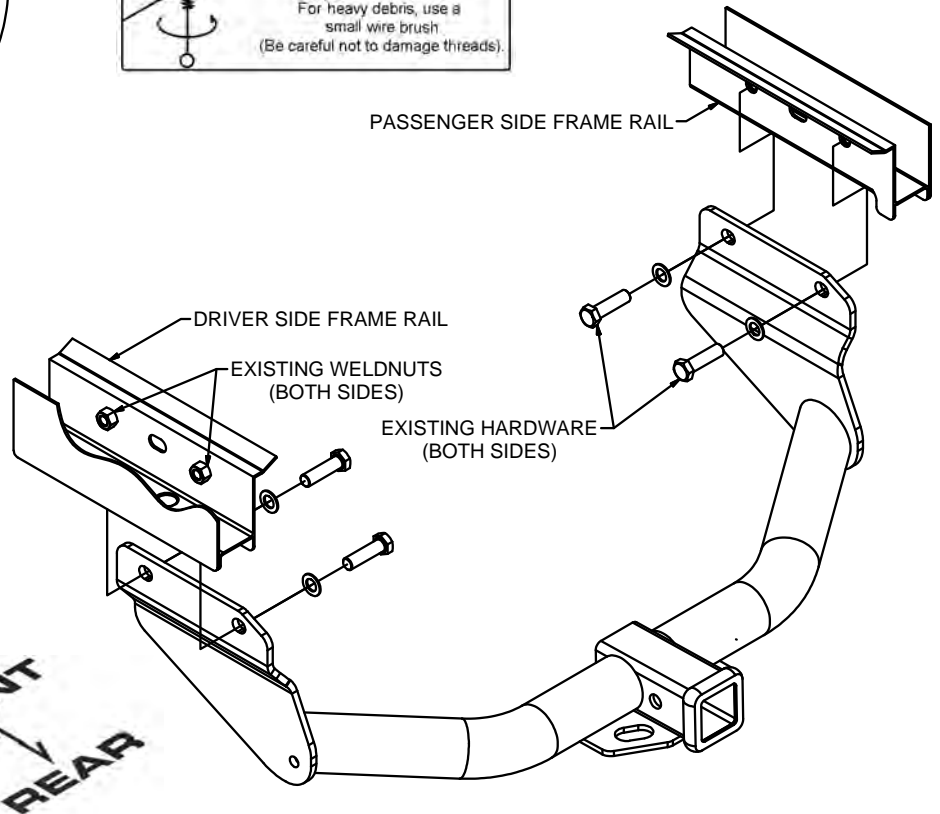
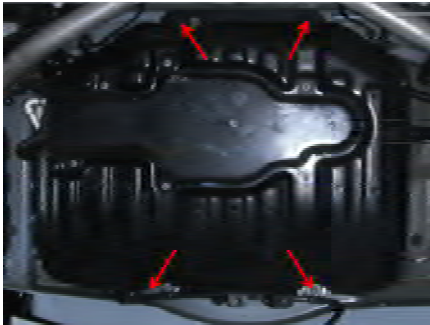

HITCH WEIGHT: 30 LBS.

INSTALL TIME

PROFESSIONAL: 10-30 MINUTES

NOVICE (DIY): 20-60 MINUTES

INSTALL NOTES:

- NO DRILLING REQUIRED
- DIESEL MODELS REQUIRE (DEF) TANK LOWERING

INSTALLATION STEPS

Diesel models only:

Due to the Diesel Exhaust Fluid (DEF) Tank location, it will need to be lowered to access the passenger side bolts. **It is highly recommended that the tank is well supported before removing the fasteners as the tank may weigh as much as 80 lbs.** Start lowering the tank by unclipping the electrical connection on the passenger side and sliding the clips off of the rear studs holding the tank. Using a 13mm socket, remove the rear stud posts and the 2 bolts on the front side of the tank. (See photo above) **DO NOT REMOVE THE FILLER PIPE FROM TANK.** The tank should be free to rotate slightly downward on the passenger side for access to the bolts/weld nuts.

Note: If factory tow loop is present you will need to remove it prior to install.

1. Remove existing M14 bolts. There will be (4) or (6) bolts depending on vehicle model. Retain (4) bolts for hitch installation. Return remaining bolts (if any) to vehicle owner.
2. Raise hitch into position and reinstall (4) M14 bolts. Note: Trim excess caulk on vehicle frame rails if it interferes with hitch installation.
3. Torque all M14 hardware to 126 lb-ft. Reinstall DEF tank if lowered on diesel models and reconnect electrical components. Torque DEF tank studs to 21 lb-ft and the DEF tank Hex Bolts to 24 lb-ft.

PERIODICALLY CHECK THIS RECEIVER HITCH TO ENSURE THAT ALL FASTENERS ARE TIGHT AND THAT ALL STRUCTURAL COMPONENTS ARE SOUND.



Scan for more information

CURT Manufacturing LLC., warrants this product to be free of defects in material and/or workmanship at the time of retail purchase by the original purchaser. If the product is found to be defective, CURT Manufacturing LLC., may repair or replace the product, at their option, when the product is returned, prepaid, with proof of purchase. Alteration to, misuse of, or improper installation of this product voids the warranty. CURT Manufacturing LLC.'s liability is limited to repair or replacement of products found to be defective, and specifically excludes liability for incidental or consequential loss or damage.