



Safety glasses should be worn at all times while installing this product.

YEARS: 2015-PRESENT

MAKE: MERCEDES / INFINITI

MODEL: GLA250 / QX30

STYLE: SUV

WARNING: NEVER EXCEED YOUR VEHICLE MANUFACTURER'S RECOMMENDED TOWING CAPACITY

WEIGHT CARRYING:
 TRAILER WEIGHT: 4,000 LBS.
 TONGUE WEIGHT: 600 LBS.

WARNING:
 WE RECOMMEND THE USE OF 18050 STABILIZING STRAPS FOR ALL NON-TRAILER (WHEEL-LESS) LOADS. PLEASE SEE THE CURT CATALOG OR VISIT US ONLINE AT WWW.CURTMFG.COM FOR FURTHER INFORMATION.

PRO INSTALL TIME: 60 MIN.
NOVICE INSTALL TIME: 120 MIN.

IF YOU ARE HESITANT TO UNDERTAKE THIS TASK ON YOUR OWN, CONTACT AN AUTHORIZED CURT INSTALLER FOR ADDITIONAL ASSISTANCE.

- INSTALLATION TIPS:**
- BEFORE YOU BEGIN INSTALLATION, READ ALL INSTRUCTIONS THOROUGHLY.
 - TO EASE INSTALLATION, 2 PEOPLE MAY BE REQUIRED.
 - USING PROPER TOOLS WILL GREATLY IMPROVE THE QUALITY OF THE INSTALL AND REDUCE THE TIME REQUIRED.
 - NEED HELP OR HAVE SOME QUESTIONS? CALL TECHNICAL SUPPORT AT 800.798.0813



INSTALLATION REQUIRES:

SAFETY GLASSES	SCREW DRIVER	RATCHET
6mm 8mm 10mm 16mm SOCKETS	T30 TORXBIT T40 SOCKETS	TORQUE WRENCH
AVIATION SHEARS	9" SOCKET EXTENSION	

LEVEL OF DIFFICULTY: CHALLENGING

EASY	MODERATE	CHALLENGING
	PART REMOVAL	
	LOWER EXHAUST	
	NO DRILLING REQUIRED	
	EXHAUST HEAT SHIELD AND REAR FASCIA TRIMMING IS REQUIRED	

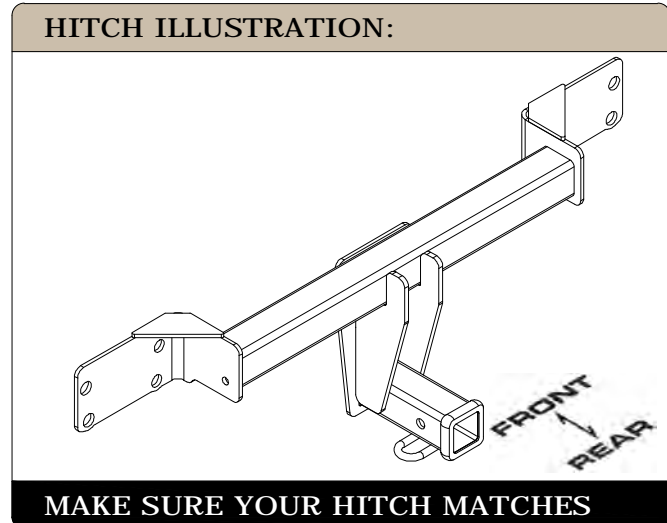

SCAN FOR MORE INFO

PERIODICALLY CHECK THIS RECEIVER HITCH TO ENSURE ALL FASTENERS ARE TIGHT AND ALL STRUCTURAL COMPONENTS ARE SOUND
 CURT Manufacturing LLC. warrants this product to be free of defects in material and/or workmanship at the time of retail purchase by the original purchaser. If the product is found to be defective, CURT Manufacturing LLC. may repair or replace the product at their option, when the product is returned, prepaid, with proof of purchase. Alteration to, misuse of, or improper installation of this product voids the warranty. CURT Manufacturing LLC.'s liability is limited to repair or replacement of products found to be defective, and specifically excludes liability for incidental or consequential loss or damage. For more information log onto www.curtmfg.com, & for helpful towing tips log onto www.hitchinfo.com

INSTALLATION WALKTHROUGH:

NOTE: REUSE EXISTING FACTORY HARDWARE

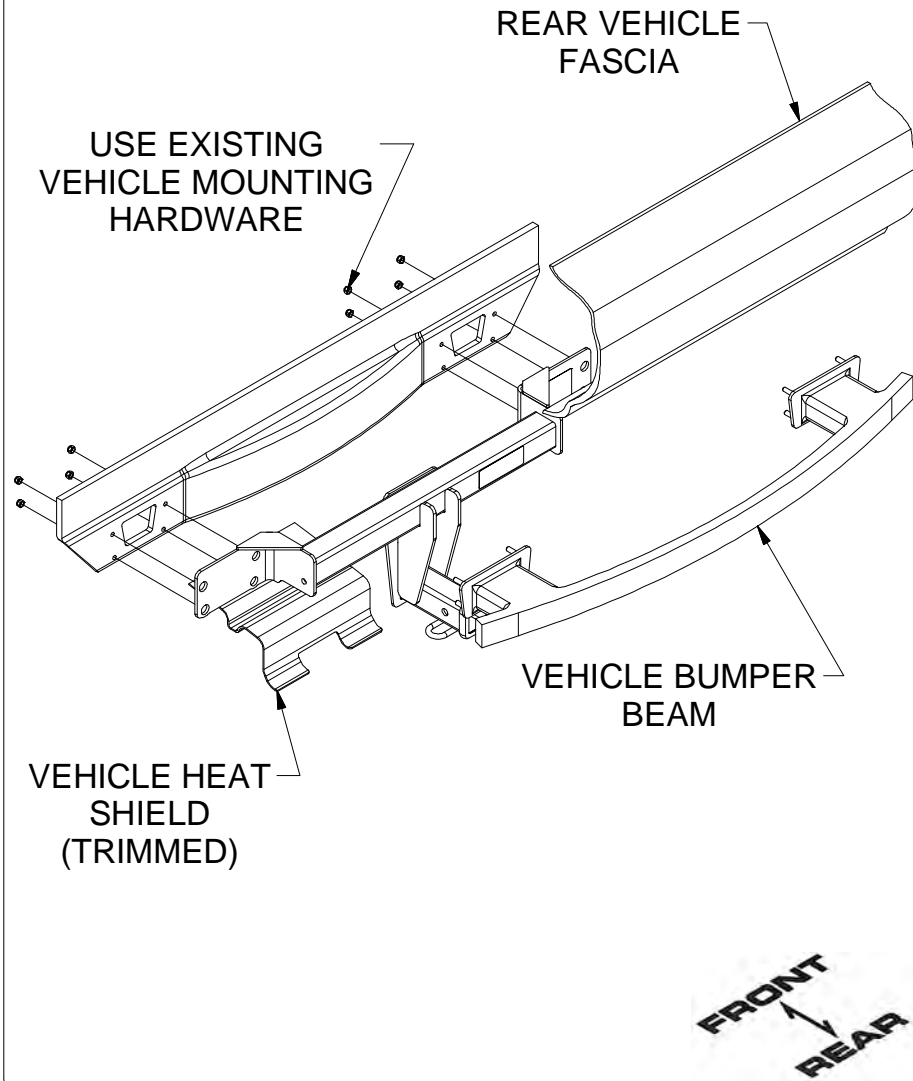

1) Remove exhaust tips by removing (4) Torx T40 bolts, (2) per side. Set aside for reassembly.

NOTE: For other models remove (4) Torx T30 bolts.

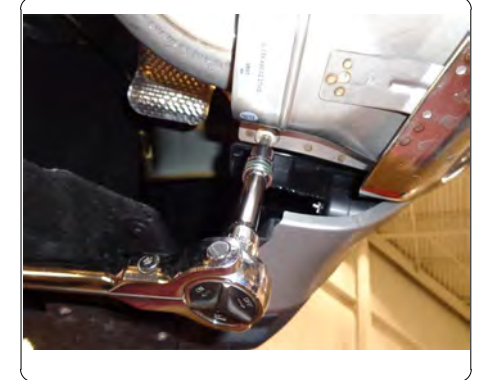

2) Lower exhaust hanger bracket, by removing (2) M10 bolts, (1) per side.

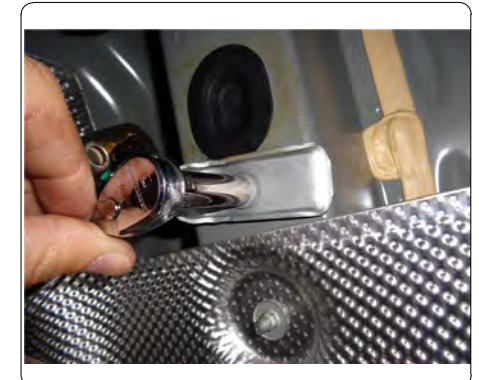

INSTALLATION WALKTHROUGH:

3) Remove (2) tail lights, (1) per side, by removing plastic wing nut on the interior panel. Set aside for reassembly.

NOTE: For other models remove (2) M10 per light, gently pull sideways away from vehicle.

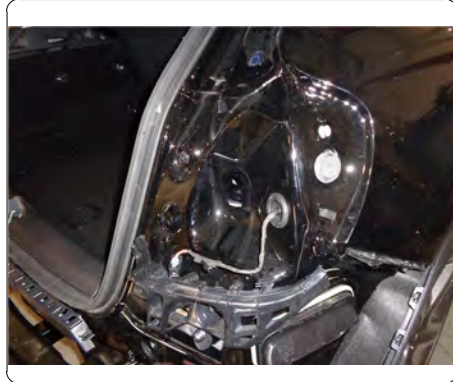

4) Remove (4) M10 bolts for plastic brackets which support the rear fascia, (2) per side. Set aside for reassembly.



5) Remove (6) M6 bolts from exhaust heat shield. Do not remove heat shield, leave in place. Lower and lay on exhaust.

NOTE: For other models remove (6) M8 bolts.



6) Partially remove (2) rear wheel well trim pieces, (1) per side, by unclipping and gently pulling away from the vehicle.

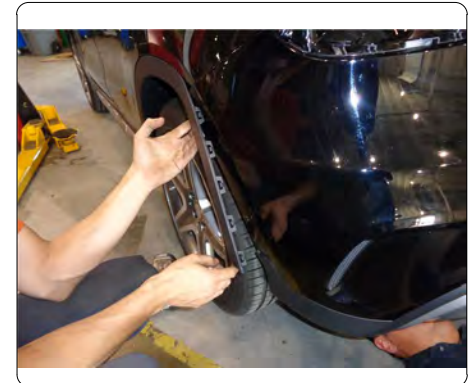
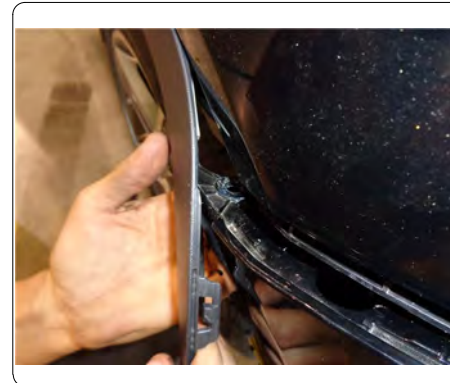

INSTALLATION WALKTHROUGH:

7) Temporarily remove rear fascia by releasing press in tabs all along top portion of fascia.
NOTE: For other models unclip (4) rear sensor plugs prior to removing rear fascia.

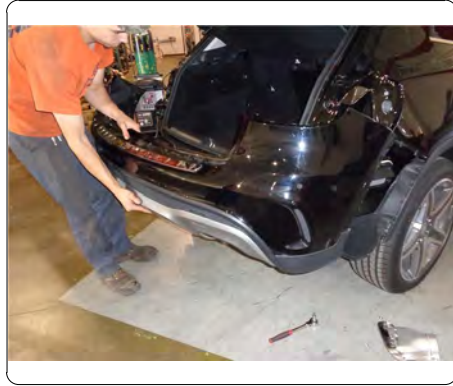

8) Remove (8) M10 nuts on inner panel to remove the bumper, (4) per side. Remove bumper. Set aside bumper and hardware for reassembly.

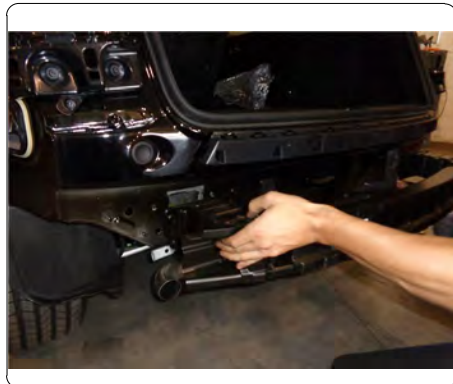

9) Align hitch on bumper through the weld on bolts.

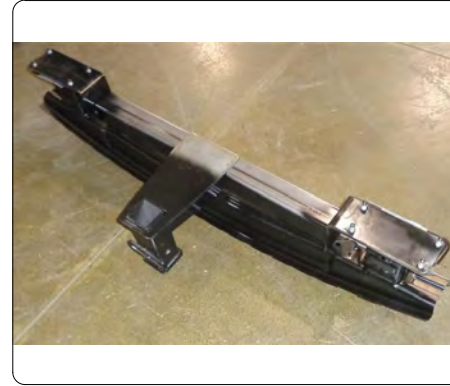

10) Place bumper/hitch on rear of vehicle through original bumper mounting holes. Loosely fasten with the M10 nuts to check fit.



INSTALLATION WALKTHROUGH:

11) Torque all M10 bolts to 37 lb-ft. Reattach heat shield and fasten (6) M6 bolts, removed in step 5.



12) Trim heat shield with shears around lower portion of hitch to avoid any contact. Approx. dimensions of cut out should be 1.25" x 4.50".

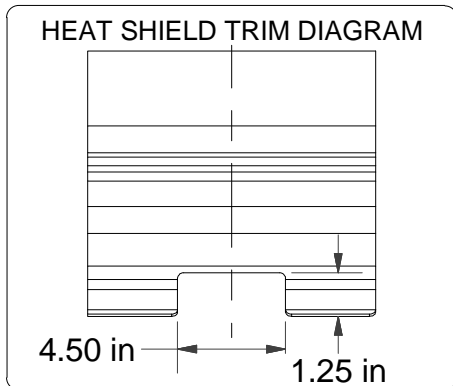

13) Reinstall rear fascia and secure press in tabs. **NOTE:** Some models will require trim as shown in the trim diagram using aviation shears. All dimensions are approximate, confirm fit prior to trimming.

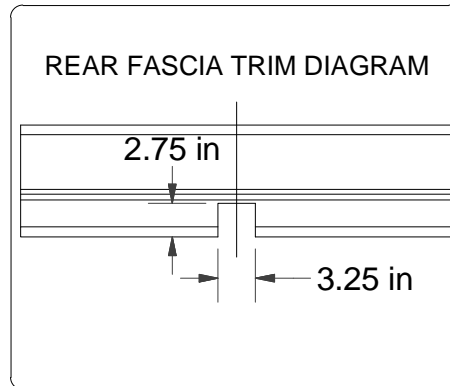
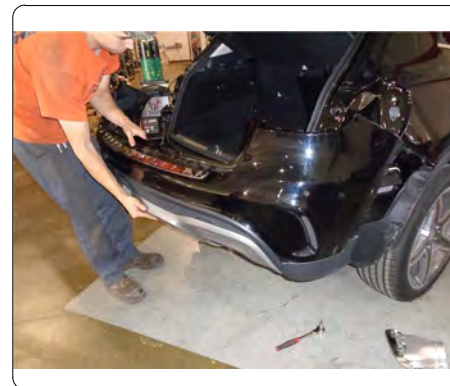

14) Follow steps 1-6 in reverse order to reattach trim pieces and tail lights.
Installation Complete.

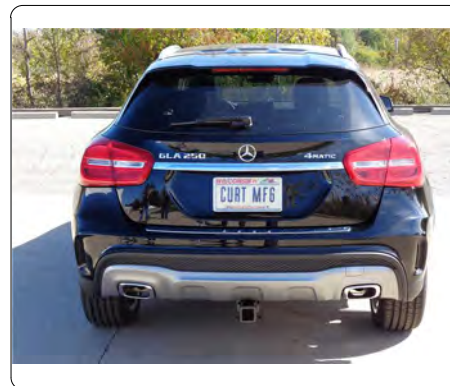

TOWING SAFETY INFORMATION

Gross Trailer Weight / GTW

The Gross Trailer Weight is the weight of the trailer & cargo. Measure this by putting the fully loaded trailer on a vehicle scale.



Tongue Weight / TW

The downward force that is exerted on the hitch ball by the coupler. The tongue weight will vary depending on where the load is positioned in relationship to the trailer axle(s). To measure the tongue weight, use either a commercial scale or a bathroom scale with the coupler at towing height. When using a bathroom scale with heavier tongue weights, use the method shown and multiply the scale reading by 3.

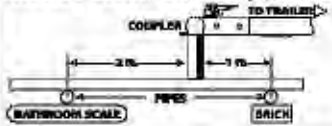

Weight Carrying / WC

The total weight of both the trailer and the cargo inside. Never exceed the weight capacity of your trailer hitch.

Weight Distribution / WD

Used to balance the weight of the cargo between the front and rear wheels throughout the trailer, allowing for better steering, braking, and level riding.



Sway Control

A device used to reduce the lateral movements of the trailer that are caused by the wind. This works in conjunction with a weight distribution hitch. Do not use this on a class 1 or 2 hitch, or with surge brakes.

How Much Can You Safely Tow?

TONGUE WEIGHT		TONGUE WEIGHT SHOULD BE ABOUT 10 TO 15 PERCENT OF THE GROSS TRAILER WEIGHT												
TRAILER TYPE		CLASS 1					CLASS 2							
Coupler		CLASS 4												
1/2" Coupler	1100	1200	1300	1400	1500	1600								
3/4" Coupler	2100	2400	2700	3000	3300	3600	3900	4200	4500	4800				
1" Coupler	2800	3200	3600	4000	4400	4800	5200	5600	6000	6400				
1 1/2" Coupler														
2" Coupler														

Refer to owner's manual for towing capabilities and limitations.

Ball Mount

The ball mount is placed inside the opening of the receiver hitch which is mounted to the vehicle. Make sure a hitch pin and clip is properly securing the ball mount to the receiver hitch before you begin towing.

• A: Rise. B: Drop. C: Hole Size. D: Length.

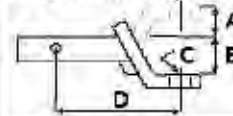

Trailer Ball

The connection from the hitch to the trailer. There are many factors that determine the correct hitch ball:

- Number one is the hitch ball's gross trailer weight rating.
- The mounting platform must be at least 3/8" thick.
- The hole diameter must not be more than 1/16" larger than the threaded shank.
- Every time you tow, check the nut and lock washer to make sure they are fastened securely.
- A: Ball Dia. B: Shank Length. C: Shank Dia. D: Shank Rise.



Coupler

The component that is placed over the trailer ball to connect the vehicle to the trailer. Be sure that the coupler size matches the size of the hitch ball and that the coupler handle is securely fastened. To determine what size hitch ball you need for your application you will need to know the size of coupler that is on the trailer. Be sure your coupler is properly adjusted to the ball you are using.

NOTE: For added security the use of safety devices such as Coupler Safety Pins and Locks is strongly recommended.

Safety Chains

Safety chains are a requirement and should be crossed under the tongue of the trailer so that the tongue will not drop to the road if it becomes separated from the hitch. Always leave enough slack so you can turn. Never allow the safety chains to drag on the ground and never attach the chains to the bumper.

Trailer Classification: Safety Chain Breaking Force - Minimum

Class 1: 2,000 lbs. (8.9 kN)

Class 2: 3,500 lbs. (15.6 kN)

Class 3: 5,000 lbs. (22.2 kN)

The strength rating of each length of safety chain or its equivalent and its attachments shall be equal to or exceed in minimum breaking force the GVWR (Gross Vehicle Weight Rating) of the trailer.

Electrical

Trailer lights, Electric Brakes, Break-away systems - Every time you tow, be sure to check that all components are working properly.

Wiring identification by color:



CURT DISCLAIMER: WIRING COLOR SHOWN WORK IN CONJUNCTION WITH CURT MANUFACTURING PRODUCTS.

GROSS LOAD CAPACITY WHEN USED AS A WEIGHT CARRYING HITCH: 4,000 LBS. TRAILER WEIGHT & 600 LBS. TONGUE WEIGHT.

DO NOT EXCEED VEHICLE MANUFACTURER'S RECOMMENDED TOWING CAPACITY.

WARNING: ALL NON-TRAILER LOADS APPLIED TO THIS PRODUCT MUST BE SUPPORTED BY 18050 STABILIZING STRAPS.

** FAILURE TO PROPERLY SUPPORT NON-TRAILER LOADS WILL VOID PRODUCT WARRANTY**

HAVING INSTALLATION QUESTIONS? CALL TECHNICAL SUPPORT AT 1-800-798-0813

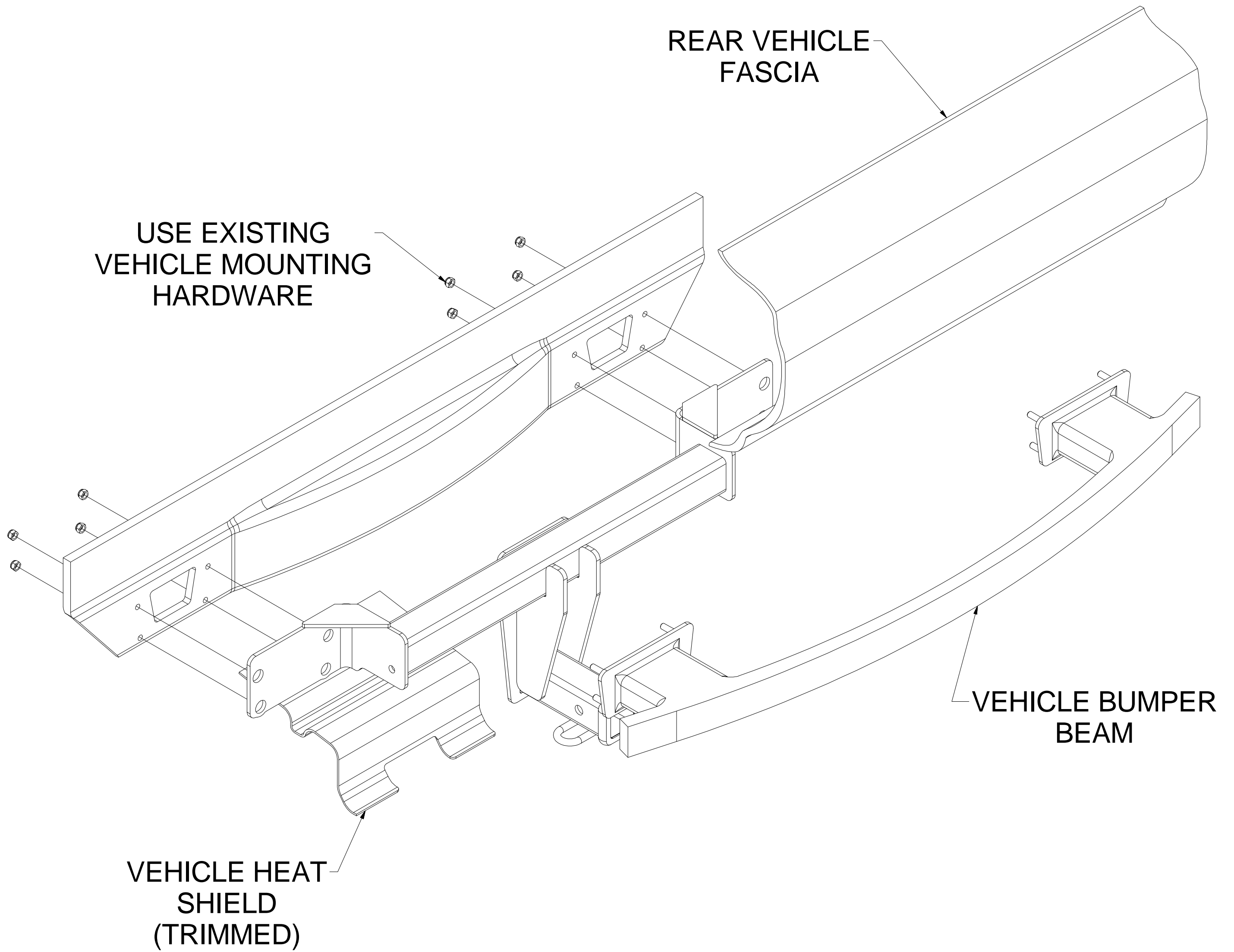

HITCH WEIGHT: 36 LBS.

INSTALL TIME

PROFESSIONAL: 60 MINUTES

NOVICE (DIY): 120 MINUTES

INSTALL NOTES:

- NO DRILLING REQUIRED
- USE EXISTING HARDWARE

TOOLS REQUIRED	
TORQUE WRENCH	
RATCHET	
9" SOCKET EXTENSION	
6mm 8mm 10mm 16mm SOCKETS	
T30 & T40 TORXBIT SOCKETS	
SCREW DRIVER	
AVIATION SHEARS	
SAFETY GLASSES	



PERIODICALLY CHECK THIS RECEIVER HITCH TO ENSURE THAT ALL FASTENERS ARE TIGHT AND THAT ALL STRUCTURAL COMPONENTS ARE SOUND.



Scan for more information

CURT Manufacturing LLC., warrants this product to be free of defects in material and/or workmanship at the time of retail purchase by the original purchaser. If the product is found to be defective, CURT Manufacturing LLC., may repair or replace the product, at their option, when the product is returned, prepaid, with proof of purchase. Alteration to, misuse of, or improper installation of this product voids the warranty. CURT Manufacturing LLC.'s liability is limited to repair or replacement of products found to be defective, and specifically excludes liability for incidental or consequential loss or damage.

HAVING INSTALLATION QUESTIONS? CALL TECHNICAL SUPPORT AT 1-800-798-0813

HEAT SHIELD TRIM DIAGRAM

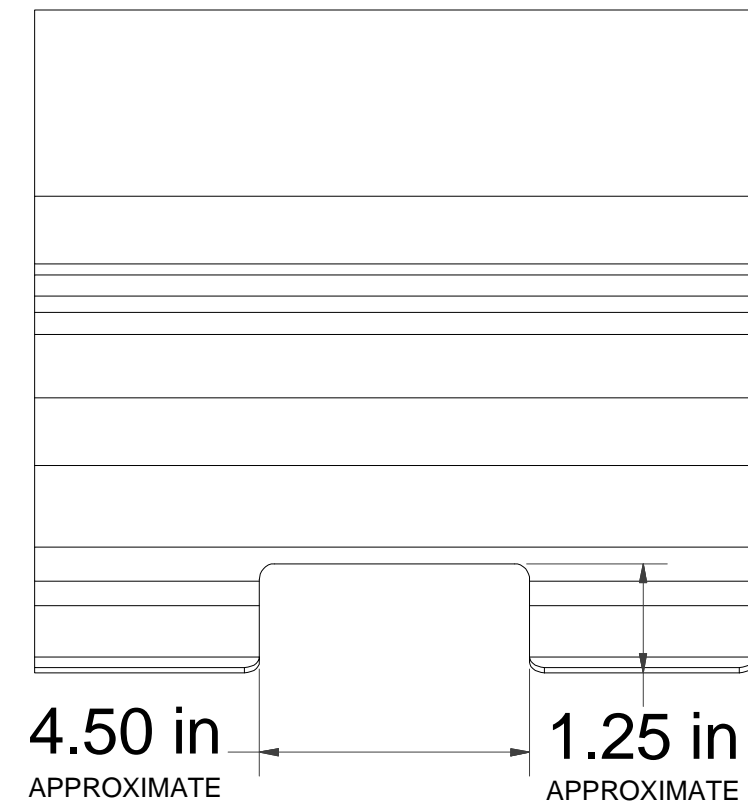

REAR FASCIA TRIM DIAGRAM

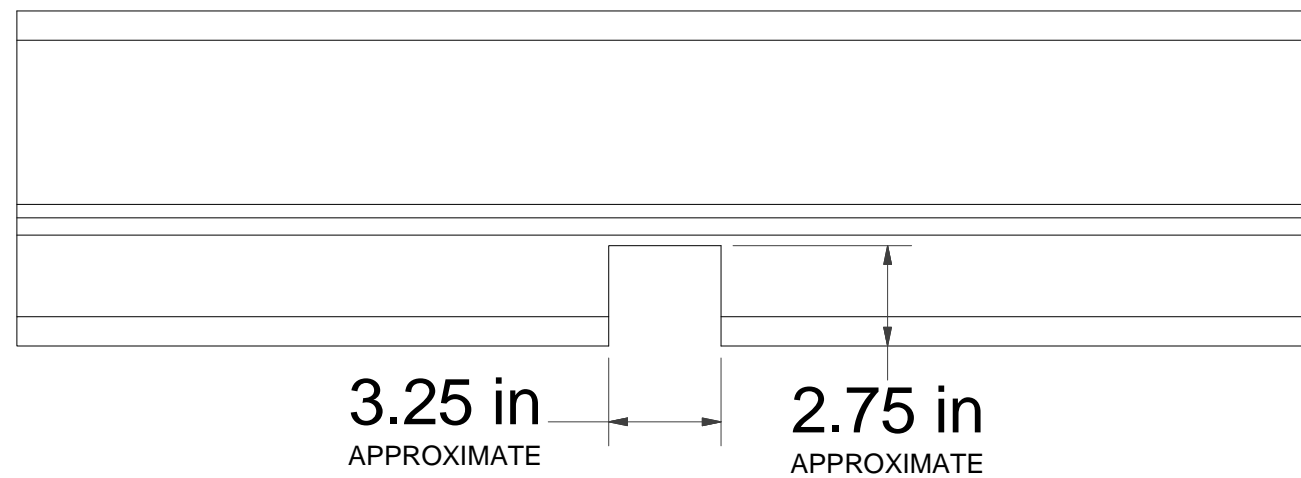

INSTALLATION STEPS

- 1) Remove exhaust tips by removing (4) Torx T40 bolts, 2 per side. Set aside for reassembly.
NOTE: For other models remove (4) Torx T30 bolts.
- 2) Lower exhaust hanger bracket, by removing (2) M10 bolts, 1 per side.
- 3) Remove (2) tail lights, 1 per side, by removing plastic wing nut on the interior panel. Set aside for reassembly.
NOTE: For other models remove (2) M10 per light, gently pull sideways away from vehicle.
- 4) Remove (4) M10 bolts for plastic brackets which support the rear fascia, 2 per side. Set aside for reassembly.
- 5) Remove (6) M6 bolts from exhaust heat shield. Do not remove heat shield, leave in place. Lower and lay on exhaust.
NOTE: For other models remove (6) M8 bolts.
- 6) Partially remove (2) rear wheel well trim pieces, 1 per side, by unclipping and gently pulling away from the vehicle.
- 7) Temporarily remove rear fascia by releasing press in tabs along top portion of fascia.
NOTE: For other models unclip (4) rear sensor plugs prior to removing rear fascia.
- 8) Remove (8) M10 nuts on inner panel to remove the bumper, 4 per side. Remove bumper. Set aside bumper and hardware for reassembly.
- 9) Align hitch on bumper through the weld on bolts.
- 10) Place bumper/hitch on rear of vehicle through original bumper mounting holes. Loosely fasten with the M10 nuts to check fit.
- 11) Torque all M10 bolts to 37 lb-ft. Reattach heat shield and fasten (6) M6 bolts, removed in step 5.
- 12) Trim heat shield with shears around lower portion of hitch to avoid any contact. Approx. dimensions of cut out should be 1.25" x 4.5".
- 13) Reinstall rear fascia and secure press in tabs.
NOTE: Some models will require trim as shown in the trim diagram using aviation shears. All dimensions are approximate, confirm fit prior to trimming.
- 14) Follow steps 1-6 in reverse order to attach trim pieces and tail lights.

Installation Complete

PERIODICALLY CHECK THIS RECEIVER HITCH TO ENSURE THAT ALL FASTENERS ARE TIGHT AND THAT ALL STRUCTURAL COMPONENTS ARE SOUND.