



Safety glasses should be worn at all times while installing this product.

YEARS: 2009-PRESENT

MAKE: DODGE

MODEL: JOURNEY (INCLUDING CROSSROAD)

STYLE: CROSSOVER

WARNING: NEVER EXCEED YOUR VEHICLE MANUFACTURER'S RECOMMENDED TOWING CAPACITY

WEIGHT CARRYING:
 TRAILER WEIGHT: 4,000 LBS.
 TONGUE WEIGHT: 400 LBS.

WEIGHT DISTRIBUTION:
 TRAILER WEIGHT: 4,000 LBS.
 TONGUE WEIGHT: 400 LBS.

PRO INSTALL TIME: 30 MIN.
NOVICE INSTALL TIME: 60 MIN.

IF YOU ARE HESITANT TO UNDERTAKE THIS TASK ON YOUR OWN, CONTACT AN AUTHORIZED CURT INSTALLER FOR ADDITIONAL ASSISTANCE.

INSTALLATION REQUIRES:

SAFETY GLASSES	PRY BAR	SPRAY LUBRICANT
RATCHET	SOCKET 3/4"	SOCKET EXTENSION 6"
JACK STANDS	TORQUE WRENCH	

INSTALLATION TIPS:

- BEFORE YOU BEGIN INSTALLATION, READ ALL INSTRUCTIONS THOROUGHLY.
- TO EASE INSTALLATION, 2 PEOPLE MAY BE REQUIRED.
- USING PROPER TOOLS WILL GREATLY IMPROVE THE QUALITY OF THE INSTALL AND REDUCE THE TIME REQUIRED.
- NEED HELP OR HAVE SOME QUESTIONS? CALL TECHNICAL SUPPORT AT 800.798.0813

LEVEL OF DIFFICULTY: EASY

EASY	MODERATE	CHALLENGING
	TEMPORARILY LOWER EXHAUST	
	FISHWIRE HARDWARE	
	NO DRILLING REQUIRED	

VEHICLE PHOTO:



REPRESENTATIVE PHOTO

HITCH ILLUSTRATION:

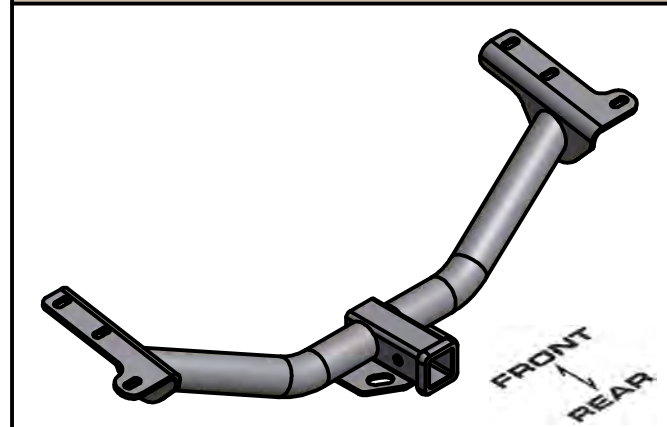

MAKE SURE YOUR HITCH MATCHES



SCAN FOR MORE INFO

PERIODICALLY CHECK THIS RECEIVER HITCH TO ENSURE ALL FASTENERS ARE TIGHT AND ALL STRUCTURAL COMPONENTS ARE SOUND
 CURT Manufacturing LLC. warrants this product to be free of defects in material and/or workmanship at the time of retail purchase by the original purchaser. If the product is found to be defective, CURT Manufacturing LLC. may repair or replace the product at their option, when the product is returned, prepaid, with proof of purchase. Alteration to, misuse of, or improper installation of this product voids the warranty. CURT Manufacturing LLC.'s liability is limited to repair or replacement of products found to be defective, and specifically excludes liability for incidental or consequential loss or damage. For more information log onto www.curtmfg.com, & for helpful towing tips log onto www.hitchinfo.com

INSTALLATION WALKTHROUGH:

Parts List			
ITEM	QTY	PART NUMBER	DESCRIPTION
1	2	CM-SP4	.250 x 1.50 x 3.00" SQUARE HOLE SPACER
2	6	HFN 1213	HEX FLANGE NUT
3	2	1_2 FISHWIRE	1/2" FISHWIRE
4	4	CM-SP12	.250 x 1.00 x 2.00" SQUARE HOLE SPACER
5	2	CM-SP38	1/2" WEDGE SPACER
6	6	1/2-13 x 1 1/2	CARRIAGE BOLT

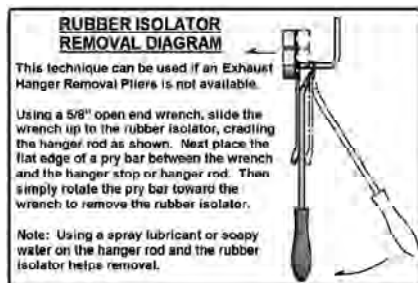
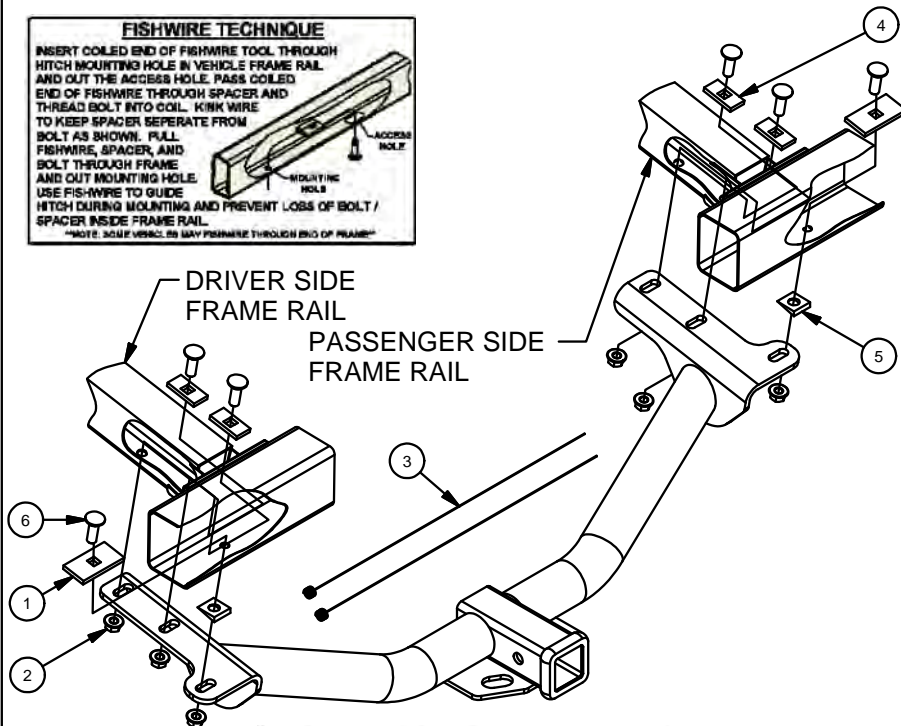
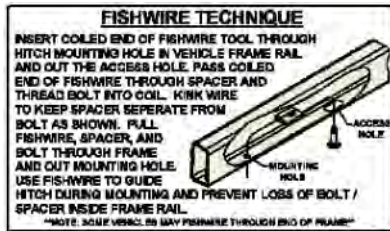

FRONT
↑
↓
REAR

1.) Lower exhaust by removing rubber isolators (3 each side) as shown.

Note: Support exhaust from underneath after lowering.

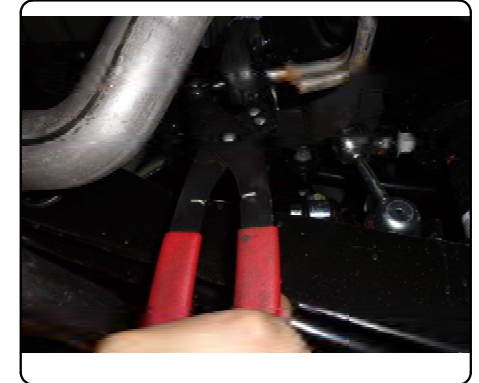
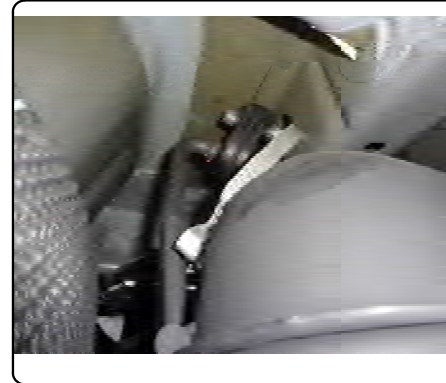

2.) Fishwire the carriage bolts and small square hole spacers through the space between the bumper beam and the end of the frame rail for both sides.

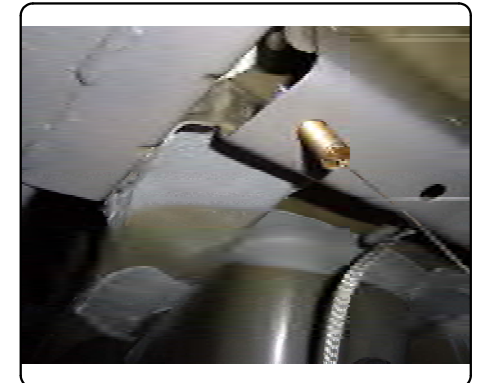
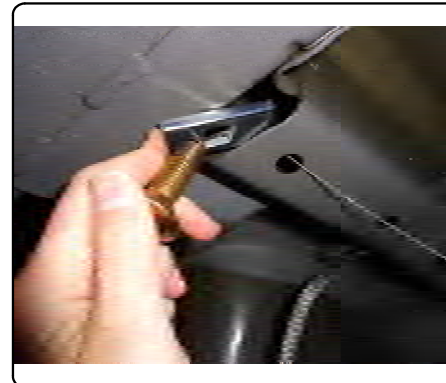

INSTALLATION WALKTHROUGH:

3.) Fishwire the remaining carriage bolts and large spacers through the bumper beam and into position.

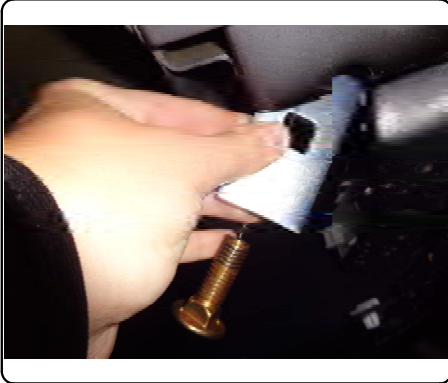

4.) Raise hitch into position with the "wedge" shaped spacers between as shown and secure with hex flange nuts.

Note: If equipped, temporarily disconnect driver side electrical connector for clearance while securing the hitch.

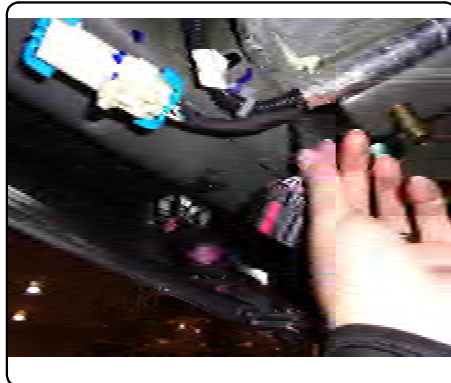
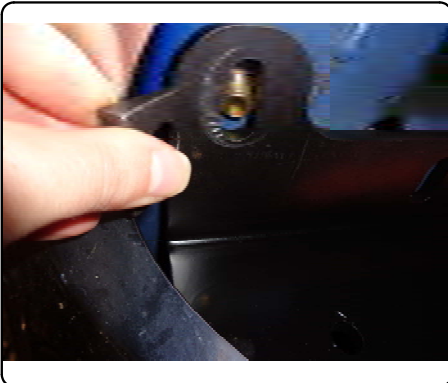

5.) Torque all 1/2" fasteners to 110 lb-ft.

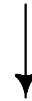

6.) Raise exhaust back into position and reinstall the (6) rubber isolators removed in Step 1.

Note: Apply lubricant or soapy water to ease installation.

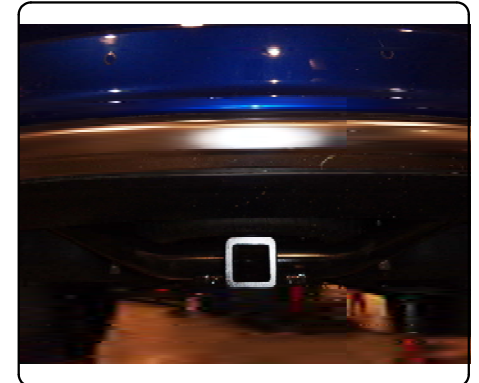

13201**DODGE JOURNEY (INCLUDING CROSSROAD)**

11/14/2014

GROSS LOAD CAPACITY WHEN USED AS A WEIGHT CARRYING HITCH: 4,000 LBS. TRAILER WEIGHT & 400 LBS. TONGUE WEIGHT.
 GROSS LOAD CAPACITY WHEN USED AS A WEIGHT DISTRIBUTION HITCH: 4,000 LBS. TRAILER WEIGHT & 400 LBS. TONGUE WEIGHT

DO NOT EXCEED VEHICLE MANUFACTURER'S RECOMMENDED TOWING CAPACITY.

HAVING INSTALLATION QUESTIONS? CALL TECHNICAL SUPPORT AT 1-800-798-0813

Parts List			
ITEM	QTY	PART NUMBER	DESCRIPTION
1	2	CM-SP4	.250 x 1.50 x 3.00" SQUARE HOLE SPACER
2	6	HFN 1213	HEX FLANGE NUT
3	6	1/2-13 x 1 1/2	CARRIAGE BOLT
4	2	1_2 FISHWIRE	1/2" FISHWIRE
5	4	CM-SP12	.250 x 1.00 x 2.00" SQUARE HOLE SPACER
6	2	CM-SP38	1/2" WEDGE SPACER

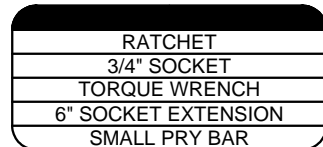
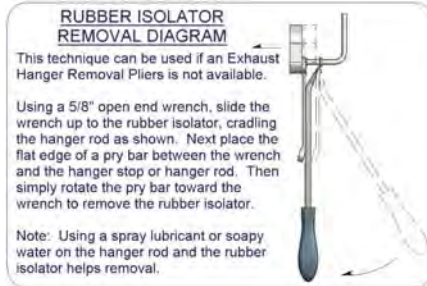
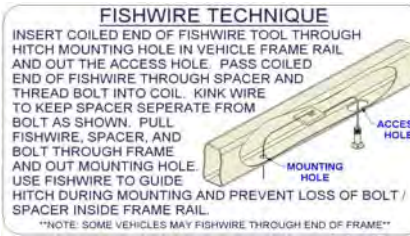

HITCH WEIGHT: 28 LBS.

INSTALL TIME

PROFESSIONAL: 30 MINUTES

NOVICE (DIY): 60 MINUTES

INSTALL NOTES:

- LOWER SPARE TIRE
- LOWER EXHAUST
- FISHWIRE HARDWARE
- NO DRILLING REQUIRED

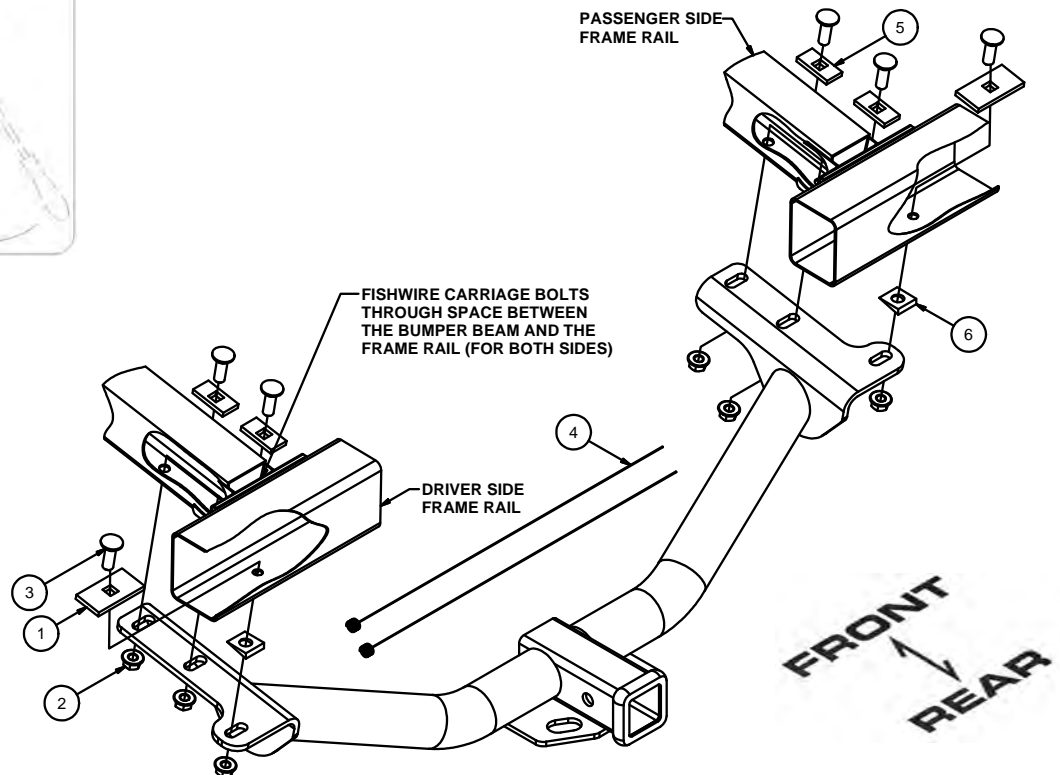
**INSTALLATION STEPS**

- 1) Lower exhaust by removing rubber isolators (3 each side) as shown in the above diagram.
NOTE: Support exhaust from underneath after lowering.
- 2) Fishwire the carriage bolts and small square hole spacers through the space between the bumper beam and the end of the frame rail for both sides.
- 3) Fishwire the remaining carriage bolts and large spacers through the bumper beam and into position.
- 4) Raise hitch into position with the "wedge" shaped spacers between as shown and secure with hex flange nuts.
NOTE: If equipped, temporarily disconnect driver side electrical connector for clearance while securing the hitch.
- 5) Torque all 1/2" fasteners to 110 lb-ft.
- 6) Raise exhaust back into position and reinstall the (6) rubber isolators removed in Step 1.
NOTE: Apply lubricant or soapy water to ease installation.



Scan for more information

PERIODICALLY CHECK THIS RECEIVER HITCH TO ENSURE THAT ALL FASTENERS ARE TIGHT AND THAT ALL STRUCTURAL COMPONENTS ARE SOUND.

CURT Manufacturing LLC., warrants this product to be free of defects in material and/or workmanship at the time of retail purchase by the original purchaser. If the product is found to be defective, CURT Manufacturing LLC., may repair or replace the product, at their option, when the product is returned, prepaid, with proof of purchase. Alteration to, misuse of, or improper installation of this product voids the warranty. CURT Manufacturing LLC.'s liability is limited to repair or replacement of products found to be defective, and specifically excludes liability for incidental or consequential loss or damage.