

13208**CHEVY/GMC 2500 & 3500 PICKUPS**

9/28/2012

GROSS LOAD CAPACITY WHEN USED AS A WEIGHT CARRYING HITCH: 8,000 LBS. TRAILER WEIGHT & 800 LBS. TONGUE WEIGHT.
 GROSS LOAD CAPACITY WHEN USED AS A WEIGHT DISTRIBUTION HITCH: 12,000 LBS. TRAILER WEIGHT & 1,200 LBS. TONGUE WEIGHT

*****DO NOT EXCEED VEHICLE MANUFACTURER'S RECOMMENDED TOWING CAPACITY.*****

Parts List				
ITEM	QTY	PART NUMBER	DESCRIPTION	
1	4	HFN 1213	HEX FLANGE NUT	
2	4	9/16	LOCK WASHER	
3	4	1/2-13 x 1 3/4	HEX BOLT	
4	2	CM-SP22	.250 x 1.50 x 1.50" ROUND HOLE SPACER	
5	4	CM-SP16	.250 x 1.50 x 2.00" ROUND HOLE SPACER	
6	2	9_16 WASHER	FLAT WASHER	
7	4	M14-2 x 40mm LG.	HEX BOLT	

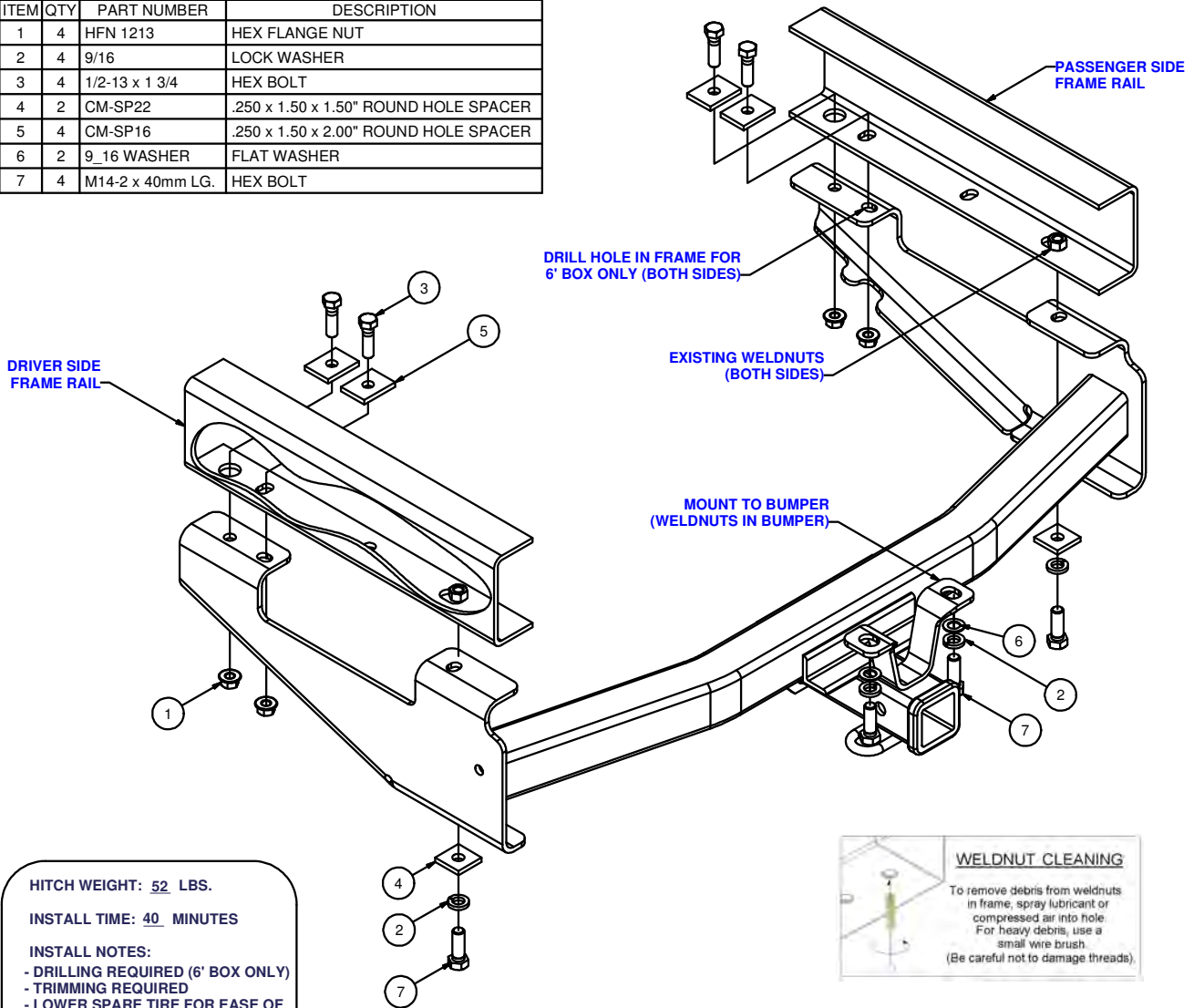

HITCH WEIGHT: 52 LBS.

INSTALL TIME: 40 MINUTES

INSTALL NOTES:

- DRILLING REQUIRED (6' BOX ONLY)
- TRIMMING REQUIRED
- LOWER SPARE TIRE FOR EASE OF INSTALLATION

INSTALLATION STEPS

- 1) Remove existing 14mm fasteners from end of each frame rail if present and return to customer.
- 2) Trim bumper fascia for access to weldnuts in bumper and clearance for bumper mount.
- 3) Lift receiver into position, locating slots in hitch over weldnuts in vehicle frame.
- 4) Install 14mm fasteners through hitch into weldnuts in vehicle frame and bumper.
- 5) On 6' short box, use hitch as a template to drill for center attachment on both sides as shown above.
- 6) Torque all 14mm fasteners to 126 lb-ft, and all 1/2" fasteners to 110 lb-ft.

PERIODICALLY CHECK THIS RECEIVER HITCH TO ENSURE THAT ALL FASTENERS ARE TIGHT AND THAT ALL STRUCTURAL COMPONENTS ARE SOUND.

Curt Manufacturing Inc., warrants this product to be free of defects in material and/or workmanship at the time of retail purchase by the original purchaser. If the product is found to be defective, Curt Manufacturing Inc., may repair or replace the product, at their option, when the product is returned, prepaid, with proof of purchase. Alteration to, misuse of, or improper installation of this product voids the warranty. Curt Manufacturing Inc.'s liability is limited to repair or replacement of products found to be defective, and specifically excludes liability for incidental or consequential loss or damage.