

13251**JEEP GRAND CHEROKEE**

7/11/2012

GROSS LOAD CAPACITY WHEN USED AS A WEIGHT CARRYING HITCH: 5000 LBS. TRAILER WEIGHT & 500 LBS. TONGUE WEIGHT.
 GROSS LOAD CAPACITY WHEN USED AS A WEIGHT DISTRIBUTION HITCH: 5500 LBS. TRAILER WEIGHT & 550 LBS. TONGUE WEIGHT

*****DO NOT EXCEED VEHICLE MANUFACTURER'S RECOMMENDED TOWING CAPACITY.*****

HAVING INSTALLATION QUESTIONS? CALL TECHNICAL SUPPORT AT 1-800-798-0813

Parts List			
ITEM	QTY	PART NUMBER	DESCRIPTION
1	4	1_2 - 13 x 4	HEX BOLT
2	4	1/2"	CONICAL TOOTHED WASHER

TOOLS REQUIRED	
RACHET	
3/4" SOCKET	
SCREWDRIVER	

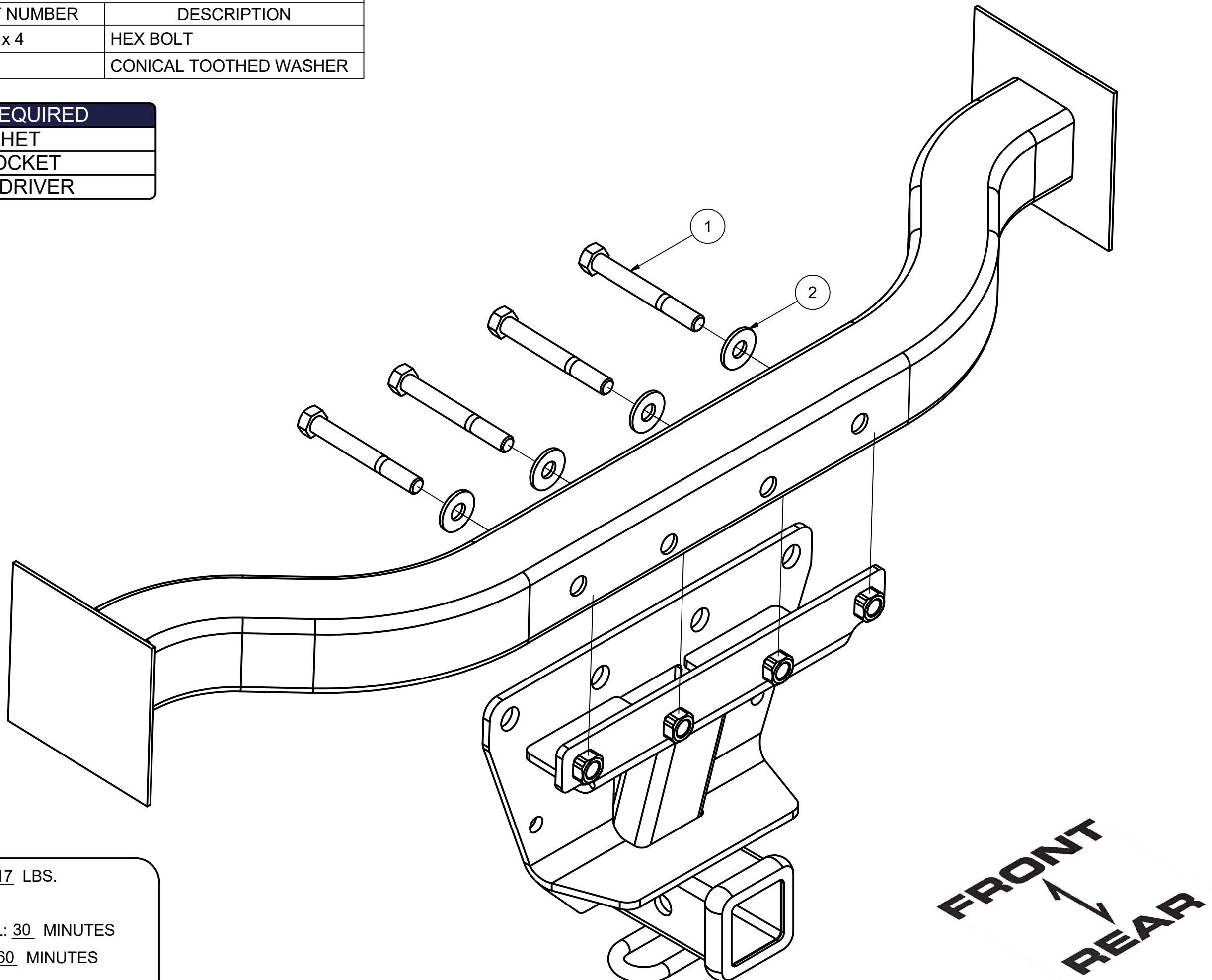

HITCH WEIGHT: 17 LBS.

INSTALL TIME

PROFESSIONAL: 30 MINUTES

NOVICE (DIY): 60 MINUTES

INSTALL NOTES:

NO DRILLING REQUIRED

INSTALLATION STEPS

- 1) Lower spare tire to allow access to the rear bumper support.
- 2) Remove tow hook (if present) and return to vehicle owner.
- 3) Remove (4) large and (2) small plastic push fasteners from bumper fascia tabs. (Reuse later)
- 4) Pull bumper cover away from vehicle and raise hitch into position. Secure hitch with hex bolts and conical washers through existing holes in bumper support.
- 5) Torque all 1/2" fasteners to 110 lb-ft.
- 6) Reinstall plastic push fasteners removed in step 2.
- 7) Raise spare tire back into position.

PERIODICALLY CHECK THIS RECEIVER HITCH TO ENSURE THAT ALL FASTENERS ARE TIGHT AND THAT ALL STRUCTURAL COMPONENTS ARE SOUND.

Curt Manufacturing Inc., warrants this product to be free of defects in material and/or workmanship at the time of retail purchase by the original purchaser. If the product is found to be defective, Curt Manufacturing Inc., may repair or replace the product, at their option, when the product is returned, prepaid, with proof of purchase. Alteration to, misuse of, or improper installation of this product voids the warranty. Curt Manufacturing Inc.'s liability is limited to repair or replacement of products found to be defective, and specifically excludes liability for incidental or consequential loss or damage.

13251**JEEP GRAND CHEROKEE ROCKY MT. EDITION****7/11/2012**

GROSS LOAD CAPACITY WHEN USED AS A WEIGHT CARRYING HITCH: 5000 LBS. TRAILER WEIGHT & 500 LBS. TONGUE WEIGHT.
 GROSS LOAD CAPACITY WHEN USED AS A WEIGHT DISTRIBUTION HITCH: 5500 LBS. TRAILER WEIGHT & 550 LBS. TONGUE WEIGHT

*****DO NOT EXCEED VEHICLE MANUFACTURER'S RECOMMENDED TOWING CAPACITY.*****

HAVING INSTALLATION QUESTIONS? CALL TECHNICAL SUPPORT AT 1-800-798-0813

Parts List			
ITEM	QTY	PART NUMBER	DESCRIPTION
1	4	1_2 - 13 x 4	HEX BOLT
2	4	1/2"	CONICAL TOOTHED WASHER
3	6	PTR516	5/16" PUSH-TYPE RETAINER

TOOLS REQUIRED
RATCHER
EXTENSION
3/4" SOCKET
10mm SOCKET
#20 TORX DRIVER
SCREWDRIVER

HITCH WEIGHT: 17 LBS.

INSTALL TIME

PROFESSIONAL: 60 MINUTES

NOVICE (DIY): 120 MINUTES

INSTALL NOTES:

NO DRILLING REQUIRED

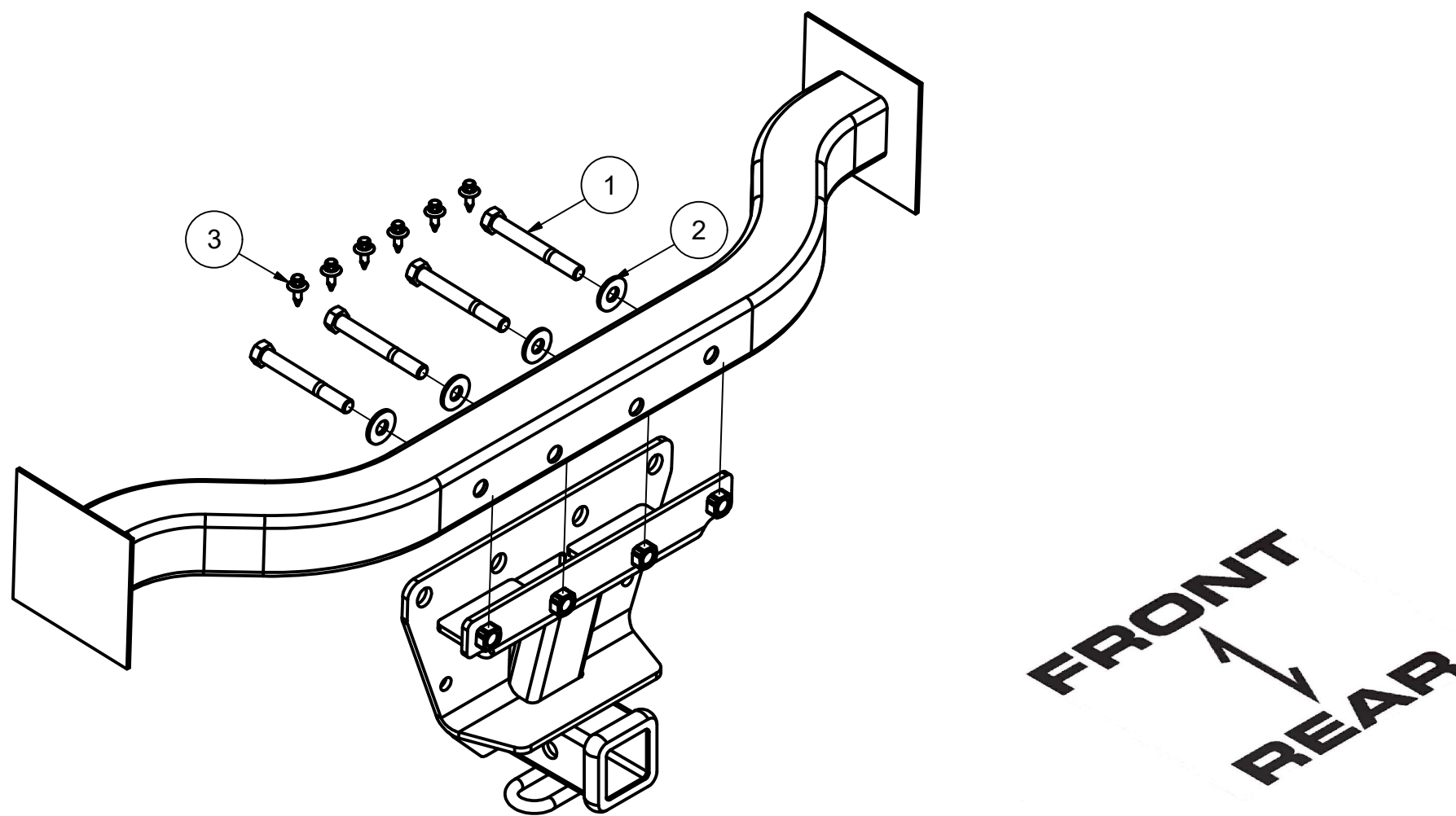

INSTALLATION STEPS

1. Lower spare tire to allow access to the rear bumper support.
2. Remove (4) large and (2) small plastic push fasteners from bumper fascia tabs.
3. Open rear hatch and remove the (4) plastic push fasteners at top of bumper cover.
4. Remove (2) torx bolts by the tail lights on the top of the bumper cover using a #20 torx driver.
5. Remove tail lights by removing the plastic push fasteners (2 per light).
6. Remove the (1) plastic push fasteners and (3) plastic pop rivets attaching the inner fender to rear bumper cover (4 per side). Note: the plastic pop rivets will need to be replaced with plastic push fasteners provided in the bolt kit.
7. Remove 10 mm nut behind the inner fender (1 per side).
8. With a pry bar, pop the clip attaching the bumper cover to the bottom corner of the tail light housing.
Note: the bumper cover should now be detached from vehicle and can be removed. (Set aside for reinstallation in step 12)
9. Once bumper cover is removed, remove the support bar that is attached to the center of the rear bumper support and the frame rail, next to the tow hook. (Return bar and hardware to vehicle owner)
10. Raise hitch into position, and secure hitch with 1/2" hex bolts and conical toothed washers through existing hole in the bumper support, as shown.
11. Torque all 1/2" fasteners to 110 lbs-ft.
12. Reinstall the rear bumper cover and tail lights removed in steps 2-8 in reverse order that they were removed.
13. Raise spare tire back into position.

PERIODICALLY CHECK THIS RECEIVER HITCH TO ENSURE THAT ALL FASTENERS ARE TIGHT AND THAT ALL STRUCTURAL COMPONENTS ARE SOUND.

Curt Manufacturing Inc., warrants this product to be free of defects in material and/or workmanship at the time of retail purchase by the original purchaser. If the product is found to be defective, Curt Manufacturing Inc., may repair or replace the product, at their option, when the product is returned, prepaid, with proof of purchase. Alteration to, misuse of, or improper installation of this product voids the warranty. Curt Manufacturing Inc.'s liability is limited to repair or replacement of products found to be defective, and specifically excludes liability for incidental or consequential loss or damage.