

13335

DODGE JOURNEY

7/11/2012

GROSS LOAD CAPACITY WHEN USED AS A WEIGHT CARRYING HITCH: 4,000 LBS. TRAILER WEIGHT & 400 LBS. TONGUE WEIGHT.
 GROSS LOAD CAPACITY WHEN USED AS A WEIGHT DISTRIBUTION HITCH: 4,000 LBS. TRAILER WEIGHT & 400 LBS. TONGUE WEIGHT

DO NOT EXCEED VEHICLE MANUFACTURER'S RECOMMENDED TOWING CAPACITY.

HAVING INSTALLATION QUESTIONS? CALL TECHNICAL SUPPORT AT 1-800-798-0813

Parts List			
ITEM	QTY	PART NUMBER	DESCRIPTION
1	2	CM-SP4	.250 x 1.50 x 3.00" SQUARE HOLE SPACER
2	6	HFN 1213	HEX FLANGE NUT
3	6	1/2-13 x 1 1/2	CARRIAGE BOLT
4	2	1_2 FISHWIRE	1/2" FISHWIRE
5	4	CM-SP12	.250 x 1.00 x 2.00" SQUARE HOLE SPACER
6	2	CM-SP38	1/2" WEDGE SPACER

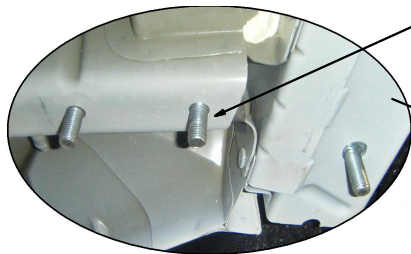

FISHWIRE CARRIAGE BOLTS THROUGH SPACE BETWEEN THE BUMPER BEAM AND THE FRAME RAIL (FOR BOTH SIDES)

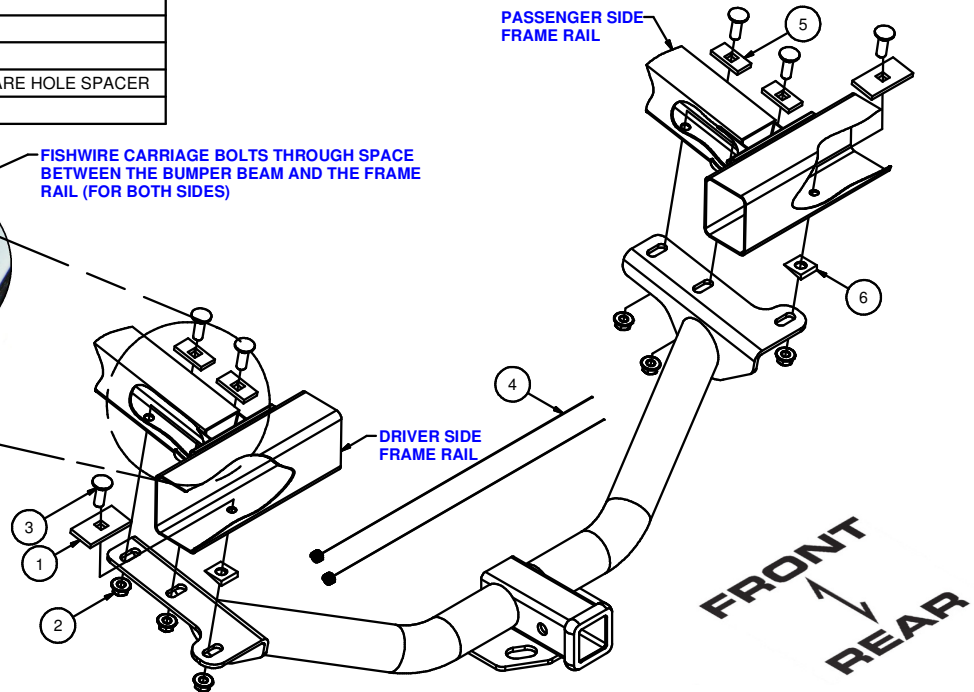

TOOLS REQUIRED

RATCHET

3/4" SOCKET

TORQUE WRENCH

5/8" OPEN END WRENCH

SMALL PRY BAR

HITCH WEIGHT: 28 LBS.

INSTALL TIME

PROFESSIONAL: 45 MINUTES

NOVICE (DIY): 90 MINUTES

INSTALL NOTES:

- LOWER SPARE TIRE
- LOWER EXHAUST
- FISHWIRE HARDWARE
- NO DRILLING REQUIRED

RUBBER ISOLATOR REMOVAL DIAGRAM

This technique can be used if an Exhaust Hanger Removal Pliers is not available.

Using a 5/8" open end wrench, slide the wrench up to the rubber isolator, cradling the hanger rod as shown. Next place the flat edge of a pry bar between the wrench and the hanger stop or hanger rod. Then simply rotate the pry bar toward the wrench to remove the rubber isolator.

Note: Using a spray lubricant or soapy water on the hanger rod and the rubber isolator helps removal.

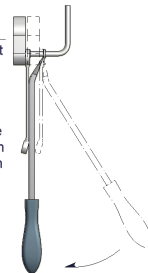

FISHWIRE TECHNIQUE

INSERT COILED END OF FISHWIRE TOOL THROUGH HITCH MOUNTING HOLE IN VEHICLE FRAME RAIL AND OUT THE ACCESS HOLE. PASS COILED END OF FISHWIRE THROUGH SPACER AND THREAD BOLT INTO COIL. KINK WIRE TO KEEP SPACER SEPARATE FROM BOLT AS SHOWN. PULL FISHWIRE, SPACER, AND BOLT THROUGH FRAME AND OUT MOUNTING HOLE. USE FISHWIRE TO GUIDE HITCH DURING MOUNTING AND PREVENT LOSS OF BOLT / SPACER INSIDE FRAME RAIL.

NOTE: SOME VEHICLES MAY FISHWIRE THROUGH END OF FRAME

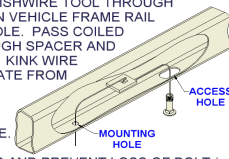

INSTALLATION STEPS

- 1) Lower exhaust by removing (4) rubber isolators as shown in the above diagram. **NOTE:** Lower spare tire for ease of installation.
- 2) Fishwire the carriage bolts and small square hole spacers through the space between the bumper beam and the end of the frame rail for both sides.
- 3) Fishwire the remaining carriage bolts and large spacers through the bumper beam and into position.
- 4) Raise hitch into position with the "wedge" shaped spacers between as shown and secure with hex flange nuts.
- 5) Torque all 1/2" fasteners to 110 lb-ft.
- 6) Raise exhaust back into position and reinstall the (4) rubber isolators removed in step 1. **NOTE:** Reapply lubricant or soapy water to ease installation.

PERIODICALLY CHECK THIS RECEIVER HITCH TO ENSURE THAT ALL FASTENERS ARE TIGHT AND THAT ALL STRUCTURAL COMPONENTS ARE SOUND.

Curt Manufacturing Inc., warrants this product to be free of defects in material and/or workmanship at the time of retail purchase by the original purchaser. If the product is found to be defective, Curt Manufacturing Inc., may repair or replace the product, at their option, when the product is returned, prepaid, with proof of purchase. Alteration to, misuse of, or improper installation of this product voids the warranty. Curt Manufacturing Inc.'s liability is limited to repair or replacement of products found to be defective, and specifically excludes liability for incidental or consequential loss or damage.