

13372

## 2006-2008 FORD F-150 (BUILT AFTER 8/5/2005)

COMPATIBLE WITH TOMMYGATE

11/26/2012

GROSS LOAD CAPACITY WHEN USED AS A WEIGHT CARRYING HITCH: 6,000 LBS. TRAILER WEIGHT & 600 LBS. TONGUE WEIGHT.  
 GROSS LOAD CAPACITY WHEN USED AS A WEIGHT DISTRIBUTION HITCH: 10,000 LBS. TRAILER WEIGHT & 1,000 LBS. TONGUE WEIGHT

\*\*\* **DO NOT EXCEED VEHICLE MANUFACTURER'S RECOMMENDED TOWING CAPACITY.** \*\*\*

HAVING INSTALLATION QUESTIONS? CALL TECHNICAL SUPPORT AT 1-800-798-0813

Parts List			
ITEM	QTY	PART NUMBER	DESCRIPTION
1	2	HFN 1213	HEX FLANGE NUT
2	2	1/2-13 x 1 3/4	CARRIAGE BOLT
3	2	1_2 FISHWIRE	1/2" FISHWIRE
4	2	CM-SP19	.250 x 1.25 x 3.00" SQUARE HOLE SPACER
5	2	1/2 - 13 x 1 1/2	HEX BOLT
6	2	FW12	FW, 12, ZP
7	2	1/2-13	HEX NUT
8	2	1/2"	LOCK WASHER
* 9	1	CM-13372-SBWA	SHIPPING BAR WELDMENT ASSEMBLY
* 10	2	1/2-13 x 1 1/4	HEX BOLT
* 11	4	1/2"	NYLON WASHER

\* REMOVE AND DISCARD SHIPPING BAR AND ATTACHING HARDWARE

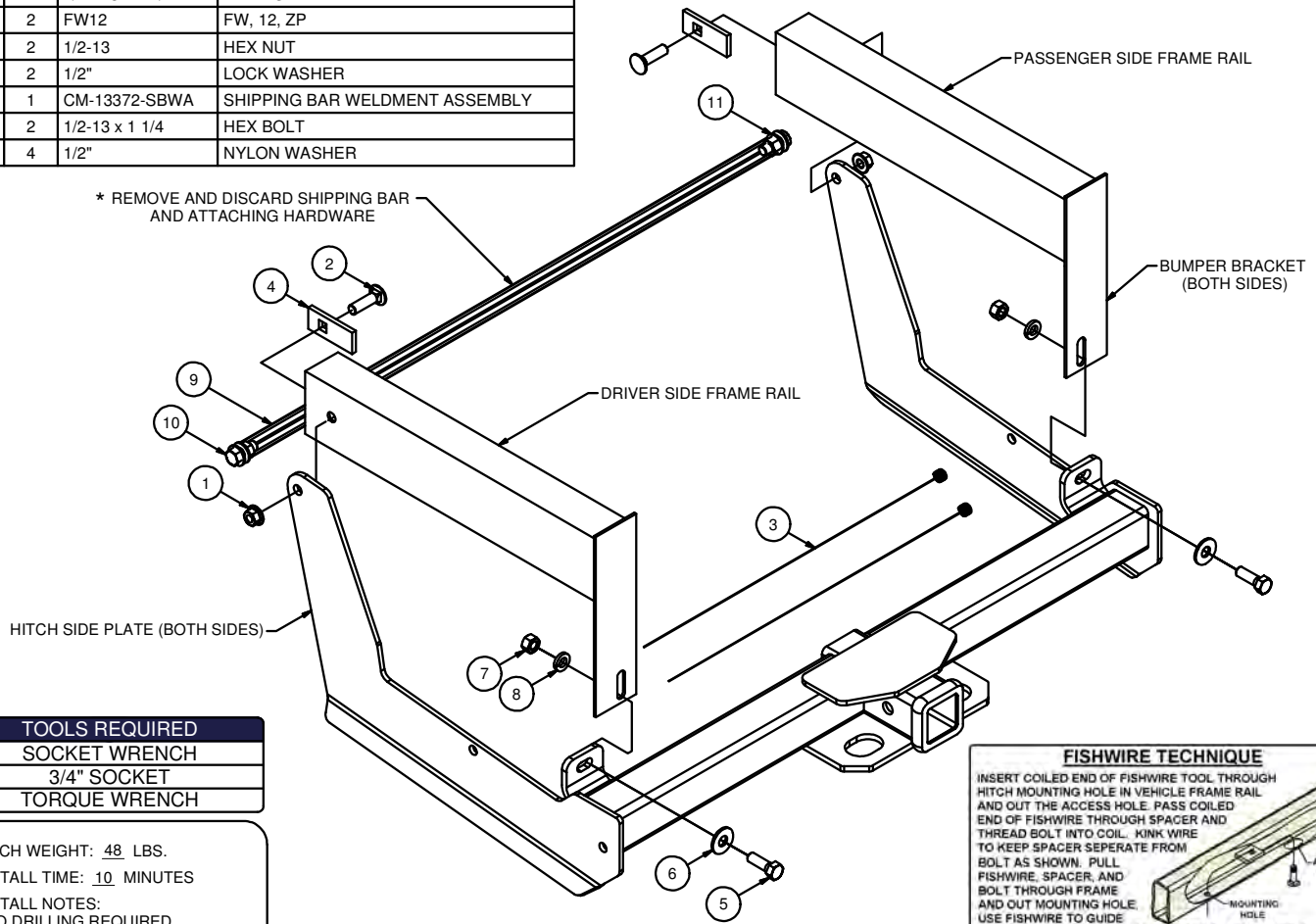

HITCH SIDE PLATE (BOTH SIDES)

**TOOLS REQUIRED**  
 SOCKET WRENCH  
 3/4" SOCKET  
 TORQUE WRENCH

HITCH WEIGHT: 48 LBS.  
 INSTALL TIME: 10 MINUTES  
 INSTALL NOTES:  
 - NO DRILLING REQUIRED  
 - FISHWIRE HARDWARE  
 - REMOVE SHIPPING BAR

#### FISHWIRE TECHNIQUE

INSERT COILED END OF FISHWIRE TOOL THROUGH HITCH MOUNTING HOLE IN VEHICLE FRAME RAIL AND OUT THE ACCESS HOLE. PASS COILED END OF FISHWIRE THROUGH SPACER AND THREAD BOLT INTO COIL. KINK WIRE TO KEEP SPACER SEPARATE FROM BOLT AS SHOWN. PULL FISHWIRE, SPACER, AND BOLT THROUGH FRAME AND OUT MOUNTING HOLE. USE FISHWIRE TO GUIDE HITCH DURING MOUNTING AND PREVENT LOSS OF BOLT / SPACER INSIDE FRAME RAIL.

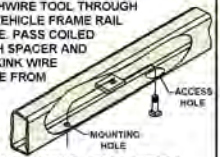

\*NOTE: SOME VEHICLES MAY FISHWIRE THROUGH END OF FRAME\*

## INSTALLATION STEPS

- \*1. Remove and discard 1/2-13 x 1 1/4 hex bolts, nylon washers and shipping bar from hitch.\*
2. Raise hitch into position.
3. Secure hitch to bumper bracket with 1/2-13 hex bolts, flat washers, hex nuts, and lock washers as shown.
4. Fishwire 1/2-13 carriage bolts and CM-SP19 spacers through frame rails and out hitch side plates.
5. Attach 1/2-13 hex flange nuts onto carriage bolts.
6. Torque 1/2" hardware to 110 lb-ft.

**PERIODICALLY CHECK THIS RECEIVER HITCH TO ENSURE THAT ALL FASTENERS ARE TIGHT AND THAT ALL STRUCTURAL COMPONENTS ARE SOUND.**

Curt Manufacturing Inc., warrants this product to be free of defects in material and/or workmanship at the time of retail purchase by the original purchaser. If the product is found to be defective, Curt Manufacturing Inc., may repair or replace the product, at their option, when the product is returned, prepaid, with proof of purchase. Alteration to, misuse of, or improper installation of this product voids the warranty. Curt Manufacturing Inc.'s liability is limited to repair or replacement of products found to be defective, and specifically excludes liability for incidental or consequential loss or damage.