

13401**73-91 CHEVY BLAZER / GMC JIMMY (FULL SIZE)**

10/1/2012

GROSS LOAD CAPACITY WHEN USED AS A WEIGHT CARRYING HITCH: 5,000 LBS. TRAILER WEIGHT & 500 LBS. TONGUE WEIGHT.
 GROSS LOAD CAPACITY WHEN USED AS A WEIGHT DISTRIBUTION HITCH: 10,000 LBS. TRAILER WEIGHT & 1,000 LBS. TONGUE WEIGHT

***** DO NOT EXCEED VEHICLE MANUFACTURER'S RECOMMENDED TOWING CAPACITY.*****

HAVING INSTALLATION QUESTIONS? CALL TECHNICAL SUPPORT AT 1-800-798-0813

Parts List			
ITEM	QTY	PART NUMBER	DESCRIPTION
1	4	HFN 1213	HEX FLANGE NUT
2	4	FW12	FW, 12, ZP
3	2	1/2-13 x 1 3/4	HEX BOLT
4	2	CM-SP44	.250 x 1.50 x 2.00" SQUARE HOLE SPACER
5	2	1/2-13 x 1 3/4	CARRIAGE BOLT

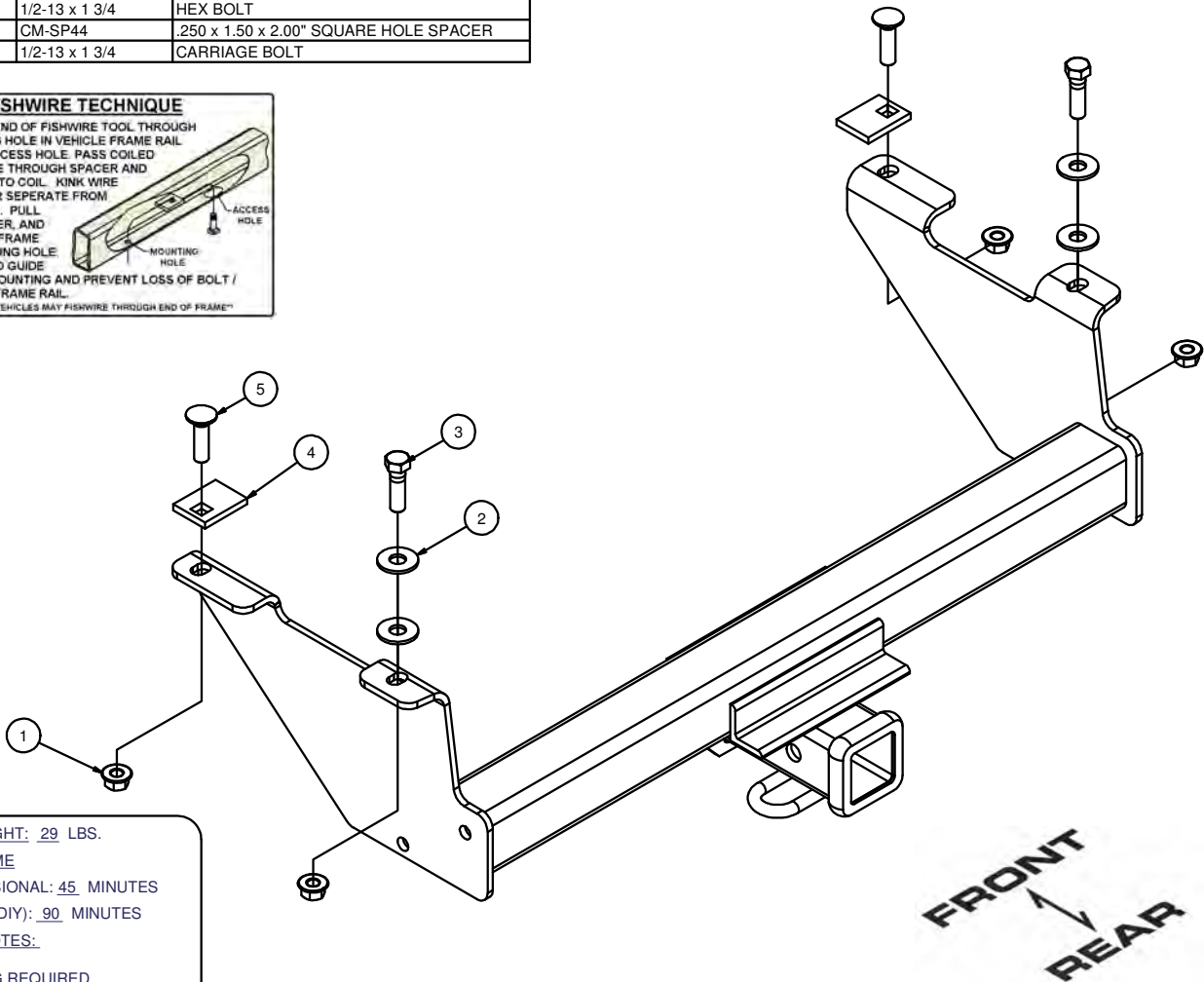
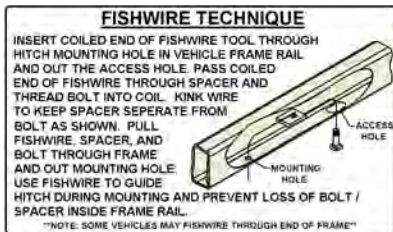

HITCH WEIGHT: 29 LBS.

INSTALL TIME

PROFESSIONAL: 45 MINUTES

NOVICE (DIY): 90 MINUTES

INSTALL NOTES:

DRILLING REQUIRED

INSTALLATION STEPS

NOTE: 1973-1980 VEHICLES, FORWARD ATTACHMENT HOLES MUST BE DRILLED.

- (1) LOCATE HOLES IN BOTTOM OF FRAME WHICH CORRESPOND TO HOLES IN HITCH. REMOVE ANY UNDERCOATING PRESENT FROM ATTACHING SURFACES BEFORE INSTALLING HITCH.
- (2) FISHWIRE APPLICABLE BOLTS AND SPACERS INTO FRAME HOLES.
- (3) RAISE HITCH INTO POSITION. PLACE ONE FLAT WASHER PER SIDE BETWEEN THE FRAME AND HITCH AT THE REARWARD ATTACHMENT LOCATION.
- (4) TORQUE ALL HARDWARE TO 110-FT-LBS USING A TORQUE WRENCH.

NOTE: REMOVAL OF LICENSE PLATE MAY BE REQUIRED TO INSTALL HITCH

PERIODICALLY CHECK THIS RECEIVER HITCH TO ENSURE THAT ALL FASTENERS ARE TIGHT AND THAT ALL STRUCTURAL COMPONENTS ARE SOUND.

Curt Manufacturing Inc., warrants this product to be free of defects in material and/or workmanship at the time of retail purchase by the original purchaser. If the product is found to be defective, Curt Manufacturing Inc., may repair or replace the product, at their option, when the product is returned, prepaid, with proof of purchase. Alteration to, misuse of, or improper installation of this product voids the warranty. Curt Manufacturing Inc.'s liability is limited to repair or replacement of products found to be defective, and specifically excludes liability for incidental or consequential loss or damage.