

**13506****01-04 FORD ESCAPE & MAZDA TRIBUTE**

7/17/2012

GROSS LOAD CAPACITY WHEN USED AS A WEIGHT CARRYING HITCH: 3,500 LBS. TRAILER WEIGHT & 350 LBS. TONGUE WEIGHT.  
 GROSS LOAD CAPACITY WHEN USED AS A WEIGHT DISTRIBUTION HITCH: 5,000 LBS. TRAILER WEIGHT & 500 LBS. TONGUE WEIGHT

**\*\*\* DO NOT EXCEED VEHICLE MANUFACTURER'S RECOMMENDED TOWING CAPACITY.\*\*\***

HAVING INSTALLATION QUESTIONS? CALL TECHNICAL SUPPORT AT 1-800-798-0813

Parts List			
ITEM	QTY	PART NUMBER	DESCRIPTION
1	4	1/2"	CONICAL TOOTHED WASHER
2	4	M12-1.75 x 45mm	HEX BOLT
3	1	1/4"	WASHER
4	1	M6 - 1.00 X 20 HEX BOLT	HEX BOLT
5	1	7_16 FISHWIRE	7/16" FISHWIRE
6	6	CM-SP2	.250 x .88 x 2.25" SQUARE HOLE SPACER
7	6	7/16-14	LARGE HEX FLANGE NUT
8	6	7/16 - 14 x 1 3/4	CARRIAGE BOLT

VEHICLES WITHOUT WELD NUTS IN FRAME

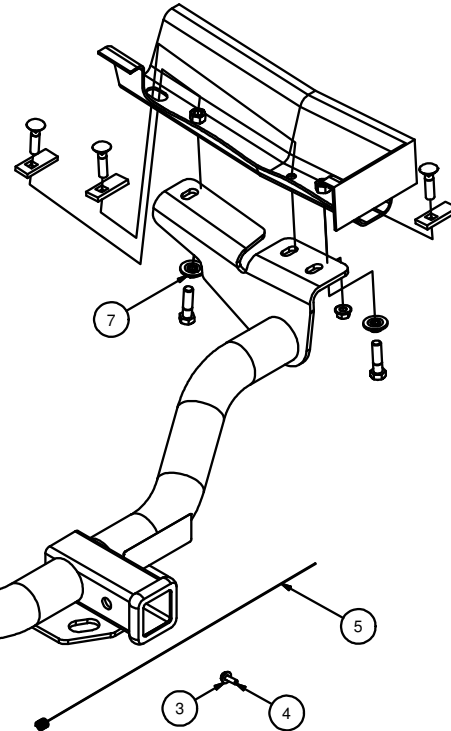
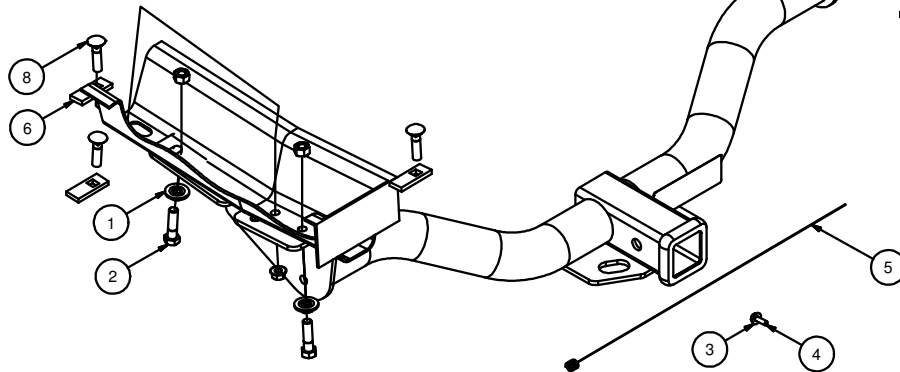
VEHICLES WITH WELD NUTS IN FRAME  
(EXISTING OEM HITCH BUMPER)**FISHWIRE TECHNIQUE**

INSERT COILED END OF FISHWIRE TOOL THROUGH HITCH MOUNTING HOLE IN VEHICLE FRAME RAIL AND OUT THE ACCESS HOLE. PASS COILED END OF FISHWIRE THROUGH SPACER AND THREAD BOLT INTO COIL. KINK WIRE TO KEEP SPACER SEPARATE FROM BOLT AS SHOWN. PULL FISHWIRE, SPACER, AND BOLT THROUGH FRAME AND OUT MOUNTING HOLE. USE FISHWIRE TO GUIDE HITCH DURING MOUNTING AND PREVENT LOSS OF BOLT / SPACER INSIDE FRAME RAIL.

\*\*NOTE: SOME VEHICLES MAY FISHWIRE THROUGH END OF FRAME\*\*

HITCH WEIGHT: 31 LBS.

**INSTALL TIME**

PROFESSIONAL: 40 MINUTES

NOVICE (DIY): 80 MINUTES

**INSTALL NOTES:**

- REMOVE HEAT SHIELD
- DRILLING REQUIRED ON SOME VEHICLES

**INSTALLATION STEPS**

- 1) Remove heat shield on 2002 and earlier models.

**For vehicles with frame weld nuts:**

Raise hitch into position and secure with hex bolts and washers as shown. Use hitch as a template to locate, and drill center holes. Install carriage bolts and spacers as shown above.

**For vehicles without frame weld nuts:**

Fishwire carriage bolts and spacers into position as shown. Raise hitch into position and fasten to hitch using supplied hex flange nuts.

- 2) Torque all 12mm fasteners to 79 lb-ft, and all 7/16" fasteners to 70 lb-ft.

- 3) Trim heat shield as required for re-fit, re-install using existing fasteners, except over hitch bracket use new 6mm hex bolt and flat washer supplied with hitch. Torque the 6mm bolt to 9 lb-ft.

**PERIODICALLY CHECK THIS RECEIVER HITCH TO ENSURE THAT ALL FASTENERS ARE TIGHT AND THAT ALL STRUCTURAL COMPONENTS ARE SOUND.**

Curt Manufacturing Inc., warrants this product to be free of defects in material and/or workmanship at the time of retail purchase by the original purchaser. If the product is found to be defective, Curt Manufacturing Inc., may repair or replace the product, at their option, when the product is returned, prepaid, with proof of purchase. Alteration to, misuse of, or improper installation of this product voids the warranty. Curt Manufacturing Inc.'s liability is limited to repair or replacement of products found to be defective, and specifically excludes liability for incidental or consequential loss or damage.