



# 13552 INSTALLATION INSTRUCTIONS



Safety glasses should be worn at all times while installing this product.

YEARS: 2010-CURRENT

MAKE: FORD

MODEL: TAURUS INCLUDING SHO

STYLE: SEDAN

**WARNING: NEVER EXCEED YOUR VEHICLE MANUFACTURER'S RECOMMENDED TOWING CAPACITY**







**WEIGHT CARRYING:**  
TRAILER WEIGHT: 4,000 LBS.  
TONGUE WEIGHT: 400 LBS.

**WARNING:**  
WE STRONGLY RECOMMEND THE USE OF AUXILIARY STABILIZING STRAPS FOR ALL NON-TRAILER (WHEEL-LESS) LOADS. PLEASE SEE THE CURT CATALOG OR VISIT US ONLINE AT [WWW.CURTMFG.COM](http://WWW.CURTMFG.COM) FOR FURTHER INFORMATION.

**INSTALLATION TIME: 30 MIN.**

THE INSTALL TIME LISTED IS FOR PROFESSIONAL INSTALLERS. IF YOU ARE HESITANT TO UNDERTAKE THIS TASK ON YOUR OWN, CONTACT AN AUTHORIZED CURT INSTALLER FOR ADDITIONAL ASSISTANCE.



**INSTALLATION REQUIRES:**

 <b>10mm 18mm 19mm</b> <b>SOCKET</b>	 <b>8"</b> <b>SOCKET EXTENSION</b>	 <b>RATCHET</b>
 <b>TORQUE WRENCH</b>	 <b>SAFETY GLASSES</b>	 <b>SPRAY LUBRICANT</b>
 <b>PRY BAR</b>		

**INSTALLATION TIPS:**

- BEFORE YOU BEGIN INSTALLATION, READ ALL INSTRUCTIONS THOROUGHLY.
- TO EASE INSTALLATION, 2 PEOPLE MAY BE REQUIRED.
- USING PROPER TOOLS WILL GREATLY IMPROVE THE QUALITY OF THE INSTALL AND REDUCE THE TIME REQUIRED.
- NEED HELP OR HAVE SOME QUESTIONS? CALL TECHNICAL SUPPORT AT 800.798.0813

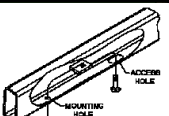
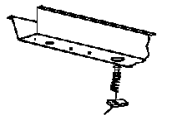
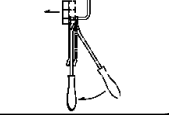
**LEVEL OF DIFFICULTY: MODERATE**

<b>EASY</b>	<b>MODERATE</b>	<b>HARD</b>
	FISHWIRE A SPACER AND BOLT INTO EXISTING FORWARD HOLE IN DRIVER SIDE FRAME RAIL. (FISHWIRE INCLUDED)	
	REVERSE PULL FISHWIRE A SPACER AND CARRIAGE BOLT INTO THE REARMOST ACCESS HOLE IN EACH FRAME RAIL. (FISHWIRE INCLUDED)	
	REMOVE RUBBER ISOLATORS FROM MUFFLERS TO LOWER THE EXHAUST. BE SURE TO SUPPORT THE EXHAUST TO AVOID DAMAGE.	
	NO DRILLING REQUIRED.	

**VEHICLE PHOTO:**



**REPRESENTATIVE PHOTO**

**HITCH ILLUSTRATION:**

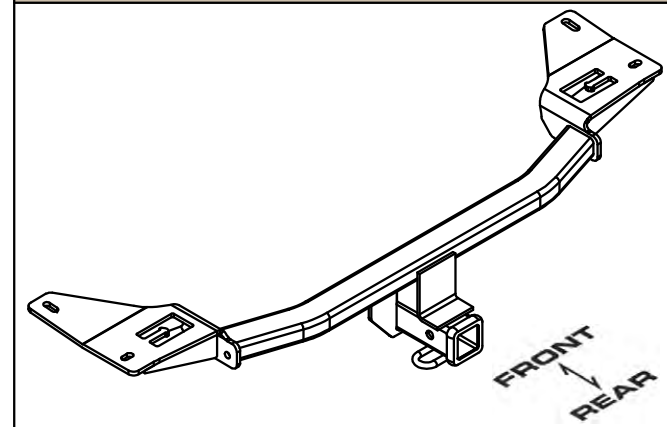

**MAKE SURE YOUR HITCH MATCHES**

**PERIODICALLY CHECK THIS RECEIVER HITCH TO ENSURE ALL FASTENERS ARE TIGHT AND ALL STRUCTURAL COMPONENTS ARE SOUND**

CURT Manufacturing Inc. warrants this product to be free of defects in material and/or workmanship at the time of retail purchase by the original purchaser. If the product is found to be defective, Curt Manufacturing Inc. may repair or replace the product at their option, when the product is returned, prepaid, with proof of purchase. Alteration to, misuse of, or improper installation of this product voids the warranty. Curt Manufacturing Inc.'s liability is limited to repair or replacement of products found to be defective, and specifically excludes liability for incidental or consequential loss or damage.

For more information log onto [www.curtmfg.com](http://www.curtmfg.com), & for helpful towing tips log onto [www.hitchinfo.com](http://www.hitchinfo.com)

# INSTALLATION WALKTHROUGH:

PARTS LIST			
ITEM	QTY	PART NUMBER	DESCRIPTION
1	3	1/2-13 x 1 1/4	CARRIAGE BOLT
2	3	CM-SP10	.250 x 1.00 x 2.50" SQUARE HOLE SPACER
3	3	HFN 1213	HEX FLANGE NUT
4	1	7/16"	CONICAL TOOTHED WASHER
5	1	M12-1.75 x 35mm	HEX BOLT
6	2	1_2 FISHWIRE	1/2" FISHWIRE

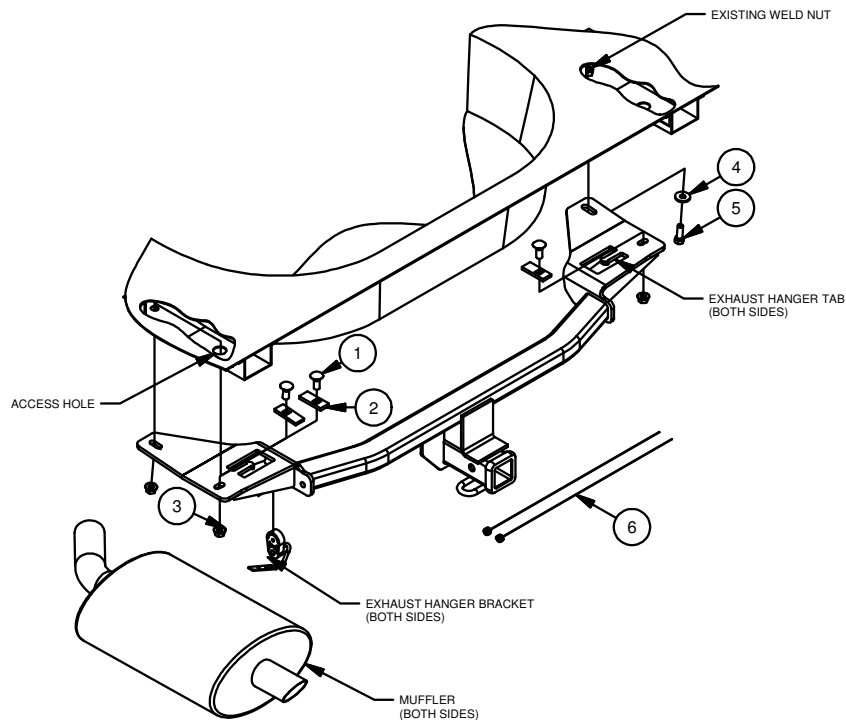

**Step 1:**  
Remove the upper exhaust hanger brackets from the rubber isolators. Save the rubber isolators for reuse in Step 10. (See Rubber Isolator Removal Diagram.)

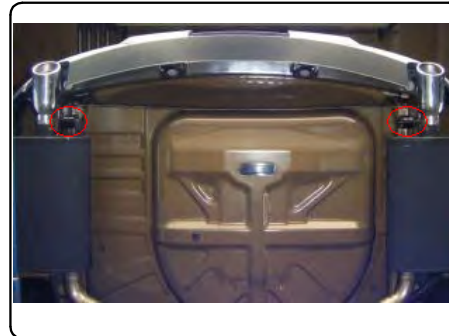

**RUBBER ISOLATOR REMOVAL DIAGRAM**

This technique can be used if and Exhaust Hanger Removal Pliers is not available.

Using a 5/8" open end wrench, slide the wrench up to the rubber isolator, cradling the hanger rod as shown. Next place the flat edge of a pry bar between the wrench and the hanger stop or hanger rod. Then simply rotate the pry bar toward the wrench to remove the rubber isolator.

Note: Using a spray lubricant or soapy water on the hanger rod and the rubber isolator helps removal.

**Step 2:**  
Support the exhaust to avoid damaging it. Remove the exhaust hangers near the exhaust split, forward of the mufflers, from the rubber isolators. (See Rubber Isolator Removal Diagram.)



## INSTALLATION WALKTHROUGH:

### Step 3:

Using a 10mm socket and ratchet, remove the (2) bolts securing the driver side exhaust isolator bracket to the frame rail and remove the bracket from the vehicle.



### Step 4:

Using a 18mm socket and ratchet, remove the (2) bolts securing the passenger side exhaust isolator bracket to the frame rail. Remove the bracket from the vehicle. Return the brackets and hardware to the vehicle owner.



### Step 5:

Using the access hole in the driver side frame rail, fishwire a 1/2-13 carriage bolt and CM-SP10 spacer into the existing hole in the frame rail. (See Fishwire Technique Diagram.)

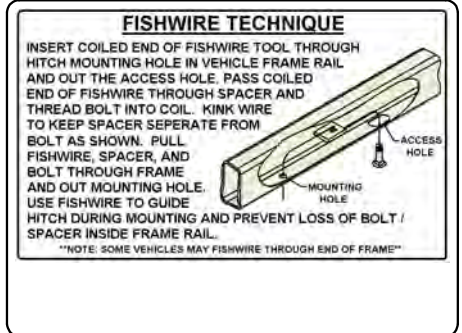
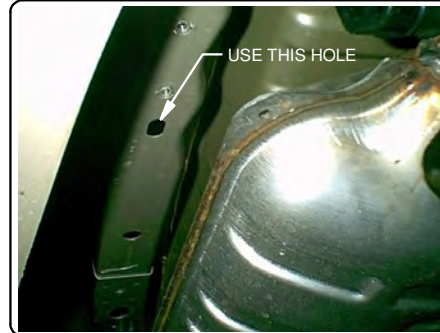

### Step 6:

Reverse pull fishwire a 1/2-13 carriage bolt and CM-SP10 spacer into the access hole in each frame rail. (See Reverse Pull Fishwire Diagram.)

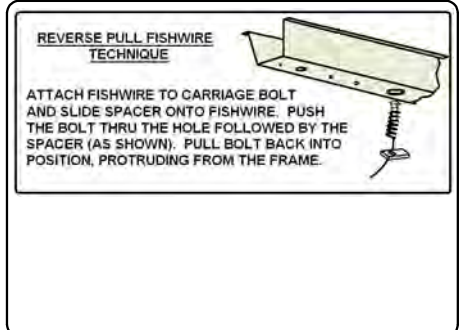

## INSTALLATION WALKTHROUGH:

Step 7:  
Carefully maneuver the hitch into position against the frame rails by going between the exhaust and the bumper cover. Align the fishwired hardware with the corresponding holes in the hitch, taking care not to push the hardware into the frame rails.



Step 8:  
Using a 19mm socket and ratchet, secure the hitch using (3) 1/2" hex flange nuts and (1) M12 hex bolt with a conical toothed washer into the existing weld nut as shown.



Step 9:  
Torque all 1/2" hardware to 110 ft-lbs.  
Torque all M12 hardware to 79 ft-lbs.



Step 10:  
Install the rubber isolators removed in Step 1 onto the muffler hangers in the side plates as shown. Raise the exhaust into position and reinstall the muffler hangers in the isolators. Reinstall the forward isolators and remove the support used during the installation.



# TOWING SAFETY INFORMATION:

## Gross Trailer Weight / GTW

The Gross Trailer Weight is the weight of the trailer & cargo. Measure this by putting the fully loaded trailer on a vehicle scale.

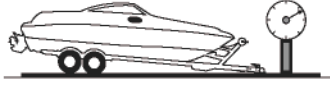

## Tongue Weight / TW

The downward force that is exerted on the hitch ball by the coupler. The tongue weight will vary depending on where the load is positioned in relationship to the trailer axle(s). To measure the tongue weight, use either a commercial scale or a bathroom scale with the coupler at towing height. When using a bathroom scale with heavier tongue weights, use the method shown and multiply the scale reading by 3.

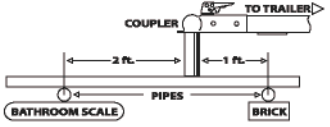

## Weight Carrying / WC

The total weight of both the trailer and the cargo inside. Never exceed the weight capacity of your trailer hitch.

## Weight Distribution / WD

Used to balance the weight of the cargo between the front and rear wheels throughout the trailer, allowing for better steering, braking, and level riding.



## Sway Control

A device used to reduce the lateral movements of the trailer that are caused by the wind. This works in conjunction with a weight distribution hitch. Do not use this on a class 1 or 2 hitch, or with surge brakes.

## How Much Can You Safely Tow?

TONGUE WEIGHT lbs	1000	2000	3000	4000	5000	6000	7000	8000	10,000	12,000
Tongue weight should be about 10 to 15 percent of the gross trailer weight.										
TRAILER TYPE	CLASS 1									
	CLASS 2									
	CLASS 3									
	CLASS 4									
	CLASS 5									
Camper	11'	12'	13'	14'	15'	16'				
lbs	1100	1200	1300	1400	1500	1600				
Vacation	14'	16'	18'	20'	22'	24'	26'	28'	30'	32'
lbs	2100	2400	2700	3000	3300	3600	3900	4200	4500	4800
Vacation	14'	16'	18'	20'	22'	24'	26'	28'	30'	32'
lbs	2800	3200	3600	4000	4400	4800	5200	5600	6000	6400
5th Wheel										

Refer to owner's manual for towing capabilities and limitations.

## Ball Mount

The ball mount is placed inside the opening of the receiver hitch which is mounted to the vehicle. Make sure a hitch pin and clip is properly securing the ball mount to the receiver hitch before you begin towing.

- A: Rise. B: Drop. C: Hole Size. D: Length.

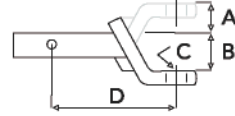

## Trailer Ball

The connection from the hitch to the trailer. There are many factors that determine the correct hitch ball:

- Number one is the hitch ball's gross trailer weight rating.
- The mounting platform must be at least 3/8" thick.
- The hole diameter must not be more than 1/16" larger than the threaded shank.
- Every time you tow, check the nut and lock washer to make sure they are fastened securely.
- A: Ball Dia. B: Shank Dia. C: Shank Length. D: Shank Rise.

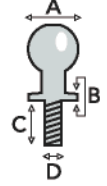

## Coupler

The component that is placed over the trailer ball to connect the vehicle to the trailer. Be sure that the coupler size matches the size of the hitch ball and that the coupler handle is securely fastened. To determine what size hitch ball you need for your application you will need to know the size of coupler that is on the trailer. Be sure your coupler is properly adjusted to the ball you are using.

NOTE: For added security the use of safety devices such as Coupler Safety Pins and Locks is strongly recommended.

## Safety Chains

Safety chains are a requirement and should be crossed under the tongue of the trailer so that the tongue will not drop to the road if it becomes separated from the hitch. Always leave enough slack so you can turn. Never allow the safety chains to drag on the ground and never attach the chains to the bumper.

Trailer Classification: Safety Chain Breaking Force - Minimum

Class 1: 2,000 lbs. (8.9 kN)

Class 2: 3,500 lbs. (15.6 kN)

Class 3: 5,000 lbs. (22.2 kN)

The strength rating of each length of safety chain or its equivalent and its attachments shall be equal to or exceed in minimum breaking force the GVWR (Gross Vehicle Weight Rating) of the trailer.

## Electrical

Trailer lights, Electric Brakes, Break-away systems - Every time you tow, be sure to check that all components are working properly.

Wiring identification by color:

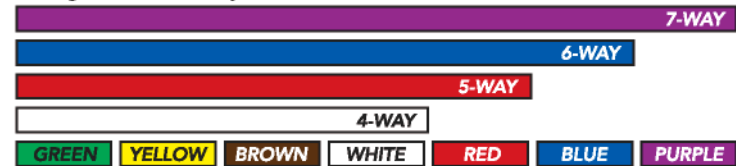

13552

FORD TAURUS INCLUDING SHO

9/28/2012

PAGE 1 of 2

GROSS LOAD CAPACITY WHEN USED AS A WEIGHT CARRYING HITCH: 4,000 LBS. TRAILER WEIGHT & 400 LBS. TONGUE WEIGHT.

\*\*\*DO NOT EXCEED VEHICLE MANUFACTURER'S RECOMMENDED TOWING CAPACITY.\*\*\*

WARNING: ALL NON-TRAILER LOADS APPLIED TO THIS PRODUCT MUST BE SUPPORTED BY AUXILIARY STABILIZING STRAPS.

\*\* FAILURE TO PROPERLY SUPPORT NON-TRAILER LOADS WILL VOID PRODUCT WARRANTY\*\*

HAVING INSTALLATION QUESTIONS? CALL TECHNICAL SUPPORT AT 1-800-798-0813

Parts List			
ITEM	QTY	PART NUMBER	DESCRIPTION
1	3	1/2-13 x 1 1/4	CARRIAGE BOLT
2	3	CM-SP10	.250 x 1.00 x 2.50" SQUARE HOLE SPACER
3	3	HFN 1213	HEX FLANGE NUT
4	1	7/16"	CONICAL TOOTHED WASHER
5	1	M12-1.75 x 35mm	HEX BOLT
6	2	1_2 FISHWIRE	1/2" FISHWIRE

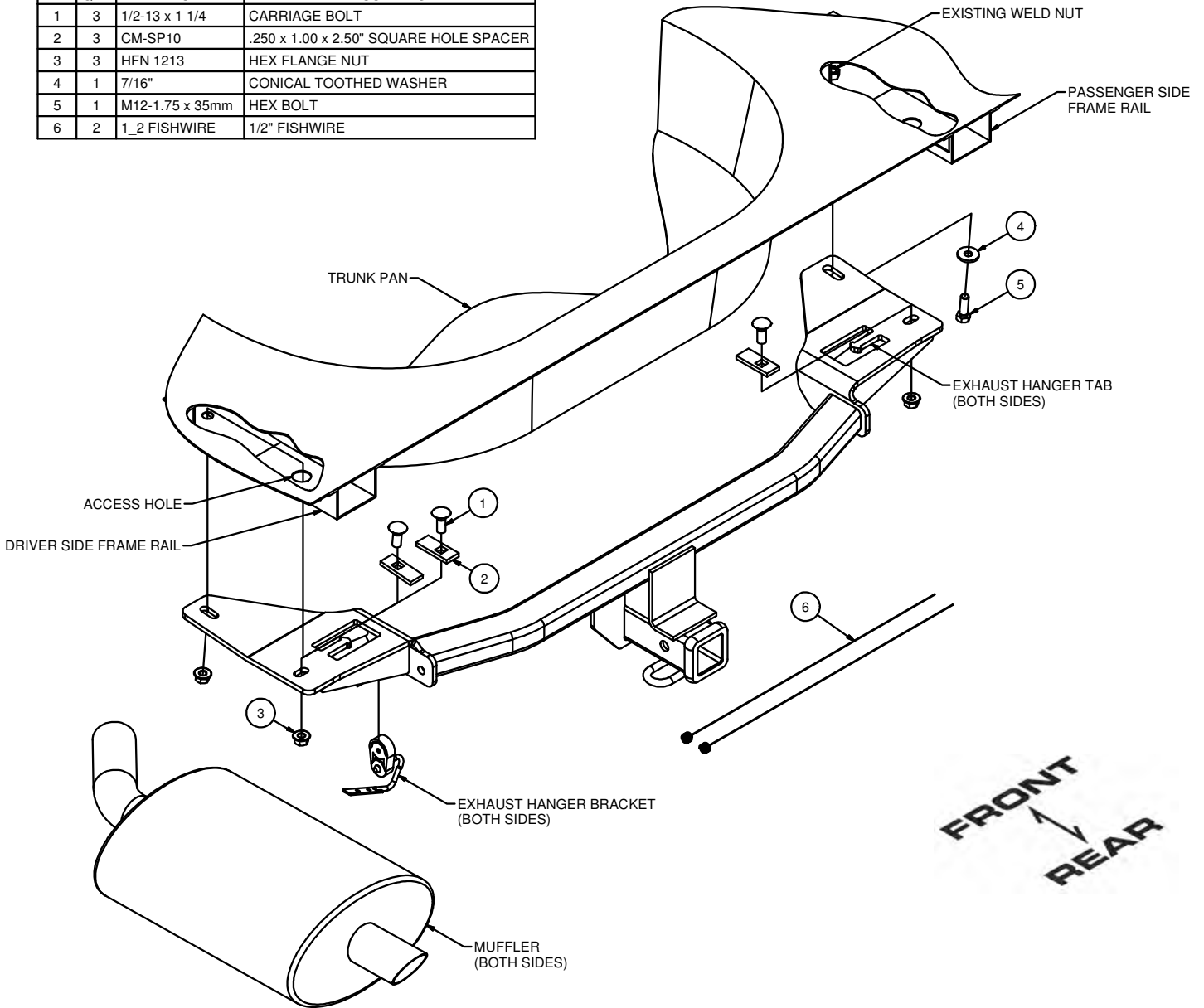

HITCH WEIGHT: 40 LBS.

INSTALL TIME

PROFESSIONAL: 30 MINUTES

NOVICE (DIY): 60 MINUTES

INSTALL NOTES:

- NO DRILLING REQUIRED

- LOWER EXHAUST

TOOLS REQUIRED

10, 18 AND 19mm SOCKETS

8" EXTENSION

RATCHET

TORQUE WRENCH

**PERIODICALLY CHECK THIS RECEIVER HITCH TO ENSURE THAT ALL FASTENERS ARE TIGHT AND THAT ALL STRUCTURAL COMPONENTS ARE SOUND.**

Curt Manufacturing Inc., warrants this product to be free of defects in material and/or workmanship at the time of retail purchase by the original purchaser. If the product is found to be defective, Curt Manufacturing Inc., may repair or replace the product, at their option, when the product is returned, prepaid, with proof of purchase. Alteration to, misuse of, or improper installation of this product voids the warranty. Curt Manufacturing Inc.'s liability is limited to repair or replacement of products found to be defective, and specifically excludes liability for incidental or consequential loss or damage.

HAVING INSTALLATION QUESTIONS? CALL TECHNICAL SUPPORT AT 1-800-798-0813

#### RUBBER ISOLATOR REMOVAL DIAGRAM

This technique can be used if an Exhaust Hanger Removal Pliers is not available.

Using a 5/8" open end wrench, slide the wrench up to the rubber isolator, cradling the hanger rod as shown. Next place the flat edge of a pry bar between the wrench and the hanger stop or hanger rod. Then simply rotate the pry bar toward the wrench to remove the rubber isolator.

Note: Using a spray lubricant or soapy water on the hanger rod and the rubber isolator helps removal.

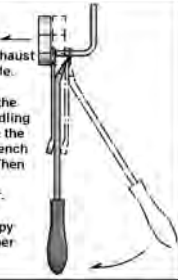

#### REVERSE PULL FISHWIRE TECHNIQUE

ATTACH FISHWIRE TO CARRIAGE BOLT AND SLIDE SPACER ONTO FISHWIRE. PUSH THE BOLT THRU THE HOLE FOLLOWED BY THE SPACER (AS SHOWN). PULL BOLT BACK INTO POSITION, PROTRUDING FROM THE FRAME.

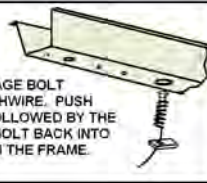

#### WELDNUT CLEANING

To remove debris from weldnuts in frame, spray lubricant or compressed air into hole. For heavy debris, use a small wire brush. (Be careful not to damage threads.)

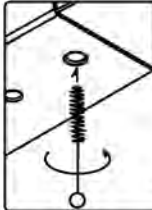

#### FISHWIRE TECHNIQUE

INSERT COILED END OF FISHWIRE TOOL THROUGH HITCH MOUNTING HOLE IN VEHICLE FRAME RAIL AND OUT THE ACCESS HOLE. PASS COILED END OF FISHWIRE THROUGH SPACER AND THREAD BOLT INTO COIL. KINK WIRE TO KEEP SPACER SEPARATE FROM BOLT AS SHOWN. PULL FISHWIRE, SPACER, AND BOLT THROUGH FRAME AND OUT MOUNTING HOLE. USE FISHWIRE TO GUIDE HITCH DURING MOUNTING AND PREVENT LOSS OF BOLT / SPACER INSIDE FRAME RAIL.

\*\*NOTE: SOME VEHICLES MAY FISHWIRE THROUGH END OF FRAME\*\*

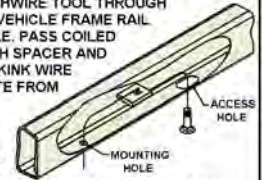

### INSTALLATION STEPS

1. Lower the mufflers by removing (2) bolts in the exhaust hanger brackets. Remove upper exhaust hanger bracket from rubber isolator. Return the exhaust hanger brackets and bolts to vehicle owner. (See Rubber Isolator Removal Diagram.)
2. Support the exhaust to avoid damaging it. Remove the exhaust hangers near the exhaust split, forward of the mufflers, from the rubber isolators. (See Rubber Isolator Removal Diagram.)
3. Fishwire 1/2-13 X 1-1/2" carriage bolt and SP10 spacer through driver side access hole and out forward most hole in frame rail. (See Fishwire Technique.)
4. Reverse fishwire 1/2-13 X 1-1/2" carriage bolts and SP10 spacers into the access holes, both sides. (See Reverse Fishwire Technique.)
5. Raise the hitch into position and secure with flange nuts as shown.
6. Secure forward most hole on passenger side with M12-1.75 X 35mm hex bolt and 1/2" conical toothed washer as shown.
7. Torque all 1/2" hardware to 110 ft-lbs. Torque all M12 hardware to 79 ft-lbs.
8. Raise the exhaust into place and secure it to the hitch by attaching the rubber isolators to the hanger tab in the hitch sideplates. (Spray lubricant or soapy water will ease the installation of the isolator onto the mount tab.)

**PERIODICALLY CHECK THIS RECEIVER HITCH TO ENSURE THAT ALL FASTENERS ARE TIGHT AND THAT ALL STRUCTURAL COMPONENTS ARE SOUND.**