



Safety glasses should be worn at all times while installing this product.

YEARS: 2009-PRESENT

MAKE: INFINITI

MODEL: FX35, FX37, FX50, QX70

STYLE: CROSSOVER

WARNING: NEVER EXCEED YOUR VEHICLE MANUFACTURER'S RECOMMENDED TOWING CAPACITY

WEIGHT CARRYING:
 TRAILER WEIGHT: 4,000 LBS.
 TONGUE WEIGHT: 400 LBS.

WARNING:
 WE RECOMMEND THE USE OF 18050 STABILIZING STRAPS FOR ALL NON-TRAILER (WHEEL-LESS) LOADS. PLEASE SEE THE CURT CATALOG OR VISIT US ONLINE AT WWW.CURTMFG.COM FOR FURTHER INFORMATION.

INSTALLATION TIME: 40 MIN.

THE INSTALL TIME LISTED IS FOR PROFESSIONAL INSTALLERS. IF YOU ARE HESITANT TO UNDERTAKE THIS TASK ON YOUR OWN, CONTACT AN AUTHORIZED CURT INSTALLER FOR ADDITIONAL ASSISTANCE.

INSTALLATION REQUIRES:

SAFETY GLASSES	SCREW DRIVER	RATCHET
SOCKET	SOCKET	SOCKET EXTENSION
TORQUE WRENCH	TAPE MEASURE	MARKER
AVIATION SHEARS		

INSTALLATION TIPS:

- BEFORE YOU BEGIN INSTALLATION, READ ALL INSTRUCTIONS THOROUGHLY.
- TO EASE INSTALLATION, 2 PEOPLE MAY BE REQUIRED.
- USING PROPER TOOLS WILL GREATLY IMPROVE THE QUALITY OF THE INSTALL AND REDUCE THE TIME REQUIRED.
- NEED HELP OR HAVE SOME QUESTIONS? CALL TECHNICAL SUPPORT AT 800.798.0813

LEVEL OF DIFFICULTY: MODERATE

EASY	MODERATE	CHALLENGING
	NO DRILLING REQUIRED	
	TOW HOOK REMOVAL	
	TRIM UNDERBODY PANEL	

VEHICLE PHOTO:



REPRESENTATIVE PHOTO

HITCH ILLUSTRATION:

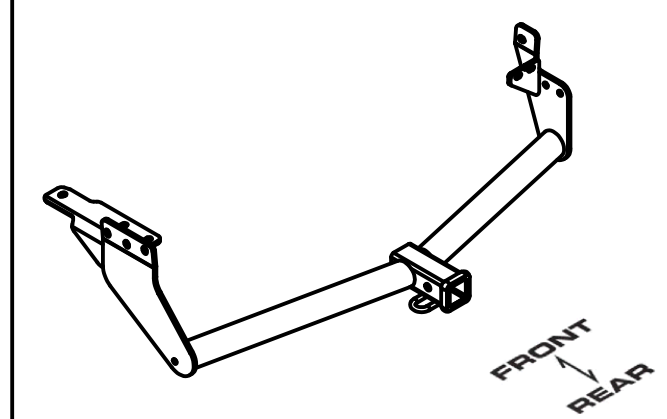

MAKE SURE YOUR HITCH MATCHES

PERIODICALLY CHECK THIS RECEIVER HITCH TO ENSURE ALL FASTENERS ARE TIGHT AND ALL STRUCTURAL COMPONENTS ARE SOUND

CURT Manufacturing LLC. warrants this product to be free of defects in material and/or workmanship at the time of retail purchase by the original purchaser. If the product is found to be defective, Curt Manufacturing LLC. may repair or replace the product at their option, when the product is returned, prepaid, with proof of purchase. Alteration to, misuse of, or improper installation of this product voids the warranty. Curt Manufacturing LLC.'s liability is limited to repair or replacement of products found to be defective, and specifically excludes liability for incidental or consequential loss or damage.

For more information log onto www.curtmfg.com, & for helpful towing tips log onto www.hitchinfo.com

INSTALLATION WALKTHROUGH:

Parts List			
ITEM	QTY	PART NUMBER	DESCRIPTION
1	4	M10 - 1.25 x 30	HEX BOLT
2	3	M12-1.25 x 35mm	HEX BOLT
3	6	3/8"	CONICAL TOOTHED WASHER
4	3	1/2"	CONICAL TOOTHED WASHER
5	2	HFN3816	HEX FLANGE NUT
6	2	1/2-13 x 1 1/4	HEX BOLT
7	2	HFN 1213	HEX FLANGE NUT
8	2	M8 - 1.25 x 30 HEX BOLT	HEX HEAD BOLT
9	2	5/16"	LOCK WASHER
10	2	5/16"	WASHER
11	1	CM-3809-UBS	3/8-16 x 1.000 x 2.50 SQ U-BOLT

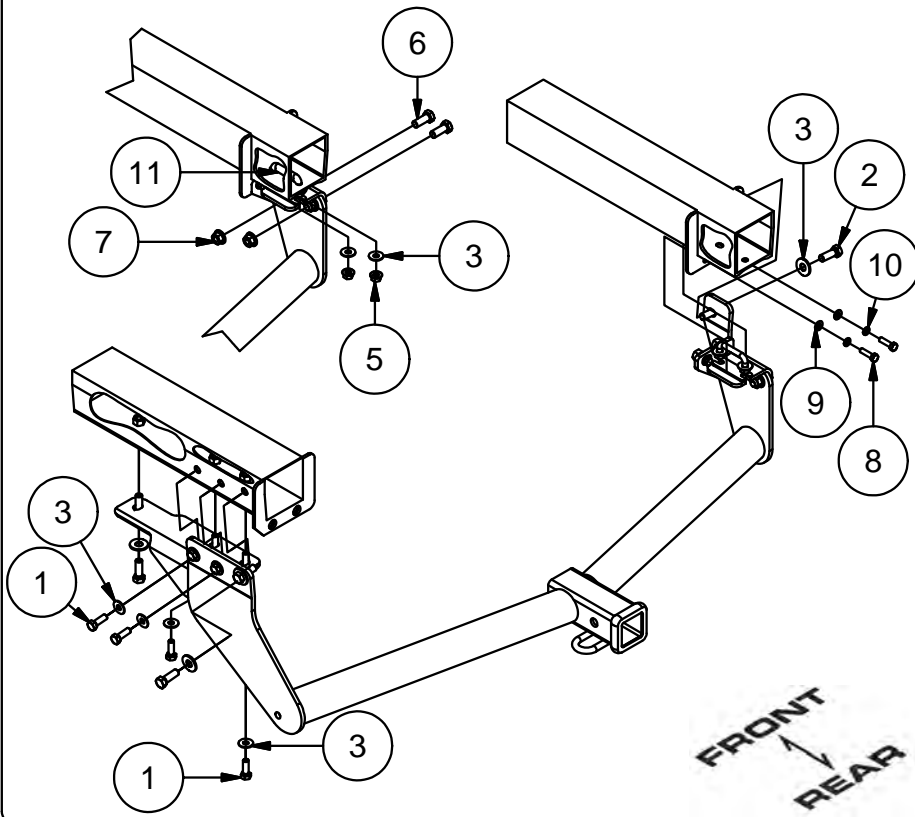

1. Remove the rear splash guards from driver and passenger side of vehicle if necessary. Remove the underbody panels by removing the (2) bolts and (11) push fasteners. Save panels and fasteners for reinstallation.

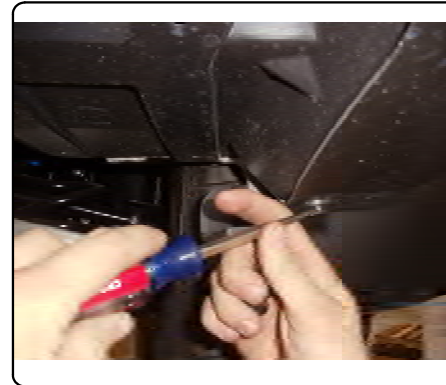

2. Remove the tow hook from the driver side frame rail by removing the (4) bolts securing it with a 14mm socket. Remove the (2) M8 bolts from the bottom of the flange on the passenger side frame rail. Return the tow hook and bolts to the vehicle owner.

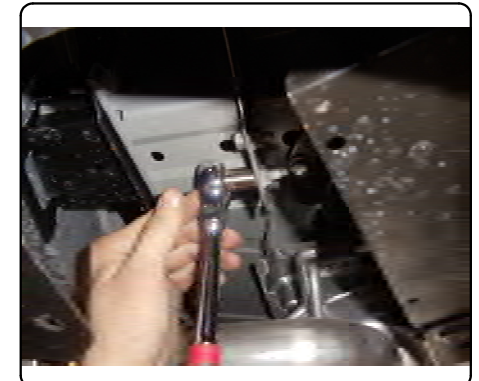
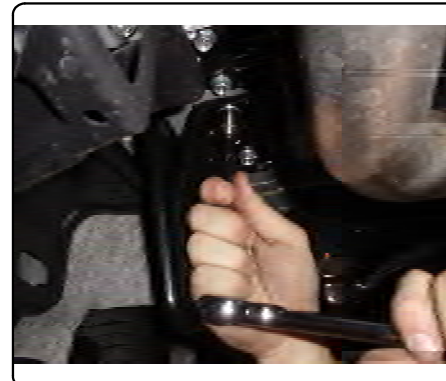

INSTALLATION WALKTHROUGH:

3. Raise hitch into position and install the (4) M10 hex bolts with 3/8" conical toothed washers and (3) M12 hex bolts with 1/2" conical toothed washers into the driver side frame rail as shown.

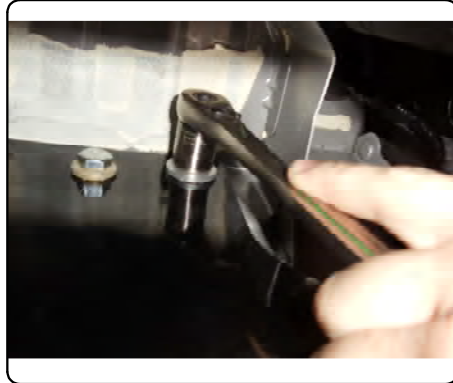
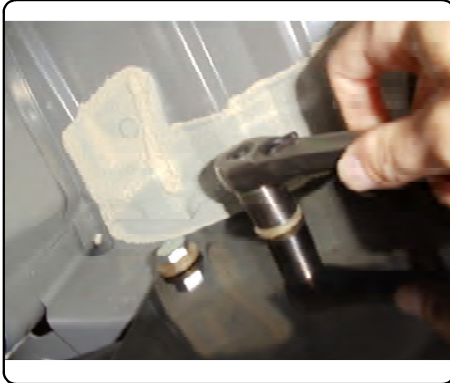

4. Secure the passenger side to the frame rail using (2) M8 hex bolts with 5/16" lock and flat washers in the position the bolts were removed from. Also, install a M12 hex bolt with a 1/2" conical toothed washer as shown in the forwardmost hole.



5. Install the u-bolt into the passenger side frame rail. Attach the mount plate weldment to the passenger side plate using (2) 1/2-13 bolts and hex flange nuts and secure to the frame rail using (2) conical toothed washers and 3/8" hex nuts.



6. Torque hardware:
M8 to 23 ft-lbs
M10 to 45 ft-lbs
M12 to 79 ft-lbs
1/2-13 to 110 ft-lbs



INSTALLATION WALKTHROUGH:

7. Trim and reinstall the passenger side underbody panel as shown. Reinstall the driverside underbody panel and reinstall splash guards if removed.

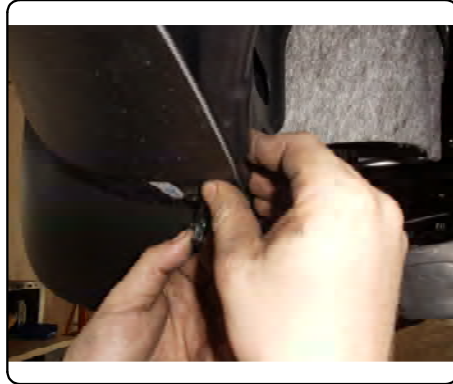

- ↓
8. Installation is complete.



13554

INFINITI FX35, FX37, FX50 AND QX70

10/15/13

GROSS LOAD CAPACITY WHEN USED AS A WEIGHT CARRYING HITCH: 4,000 LBS. TRAILER WEIGHT & 400 LBS. TONGUE WEIGHT.

DO NOT EXCEED VEHICLE MANUFACTURER'S RECOMMENDED TOWING CAPACITY.

WARNING: ALL NON-TRAILER LOADS APPLIED TO THIS PRODUCT MUST BE SUPPORTED BY AUXILIARY STABILIZING STRAPS.

** FAILURE TO PROPERLY SUPPORT NON-TRAILER LOADS WILL VOID PRODUCT WARRANTY**

HAVING INSTALLATION QUESTIONS? CALL TECHNICAL SUPPORT AT 1-800-798-0813

Parts List			
ITEM	QTY	PART NUMBER	DESCRIPTION
1	4	M10 - 1.25 x 30	HEX BOLT
2	6	3/8"	CONICAL TOOTHED WASHER
3	3	M12-1.25 x 35mm	HEX BOLT
4	3	1/2"	CONICAL TOOTHED WASHER
5	2	M8 - 1.25 x 30 HEX BOLT	HEX HEAD BOLT
6	2	5/16"	LOCK WASHER
7	2	5/16"	WASHER
8	2	HFN3816	HEX FLANGE NUT
9	2	1/2-13 x 1 1/4	HEX BOLT
10	2	HFN 1213	HEX FLANGE NUT
11	1	CM-3809-UBS	3/8-16 x 1.000 x 2.50 SQ U-BOLT

TOOLS REQUIRED
10, 12, 13, 14, 17 AND 19mm SOCKETS
SOCKET WRENCH
TORQUE WRENCH
FLAT HEAD SCREW DRIVER
PHILIPS HEAD SCREW DRIVER

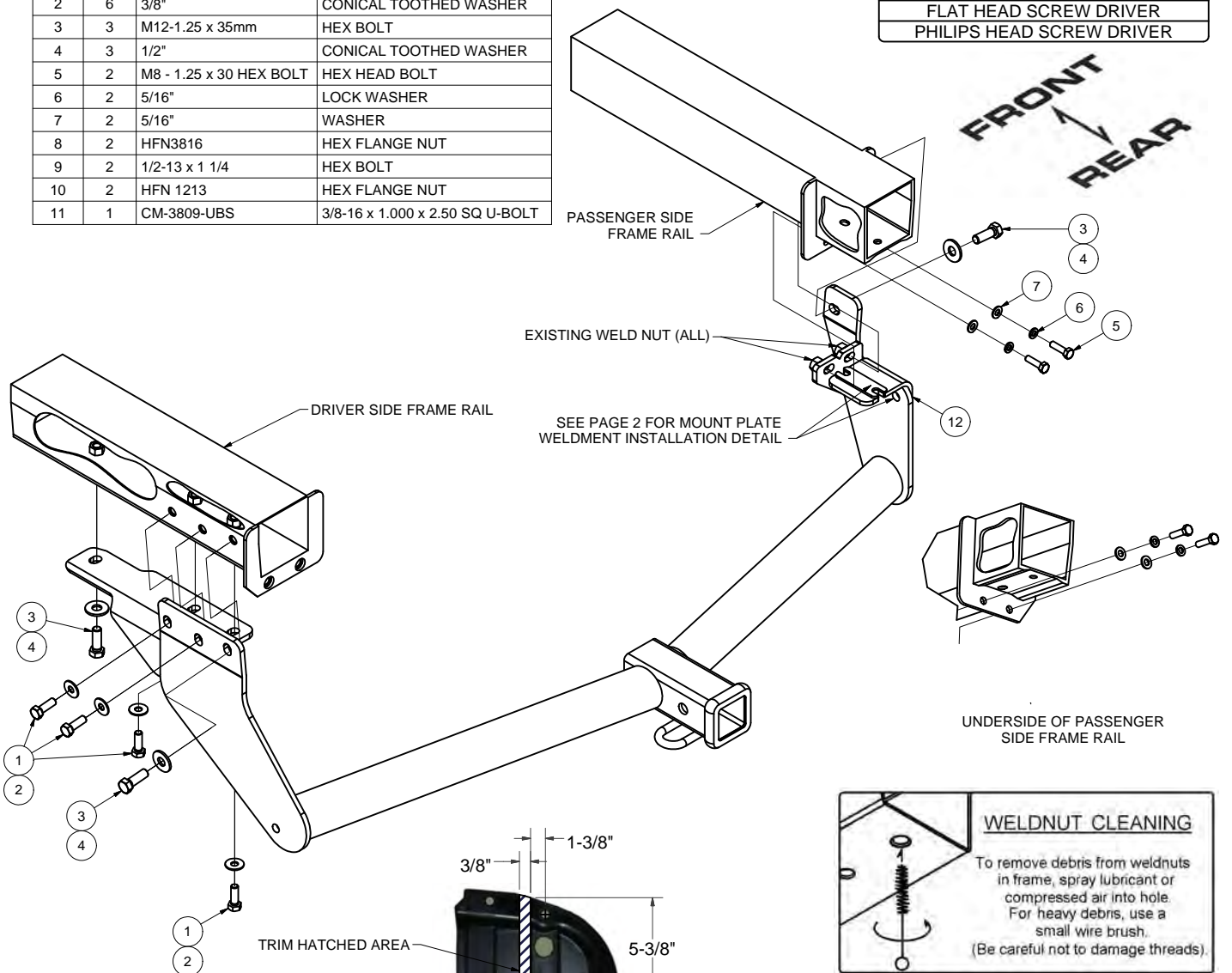

WELDNUT CLEANING

To remove debris from weldnuts in frame, spray lubricant or compressed air into hole. For heavy debris, use a small wire brush. (Be careful not to damage threads.)



PASSENGER SIDE UNDERBODY PANEL TRIM DIAGRAM

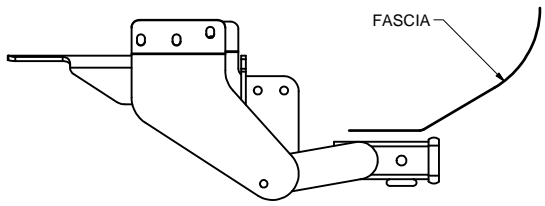

INSTALLED HITCH POSITION

HITCH WEIGHT: 39 LBS.

INSTALL TIME

PROFESSIONAL: 40 MINUTES

NOVICE (DIY): 80 MINUTES

INSTALL NOTES:

- NO DRILLING REQUIRED
- REMOVE SPLASH GUARDS
- REMOVE TOW HOOK
- REMOVE AND TRIM UNDERBODY PANELS

PERIODICALLY CHECK THIS RECEIVER HITCH TO ENSURE THAT ALL FASTENERS ARE TIGHT AND THAT ALL STRUCTURAL COMPONENTS ARE SOUND.

Curt Manufacturing Inc., warrants this product to be free of defects in material and/or workmanship at the time of retail purchase by the original purchaser. If the product is found to be defective, Curt Manufacturing Inc., may repair or replace the product, at their option, when the product is returned, prepaid, with proof of purchase. Alteration to, misuse of, or improper installation of this product voids the warranty. Curt Manufacturing Inc.'s liability is limited to repair or replacement of products found to be defective, and specifically excludes liability for incidental or consequential loss or damage.

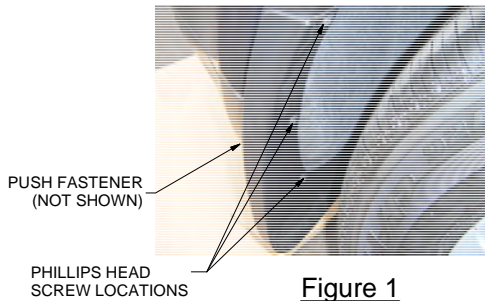

Figure 1

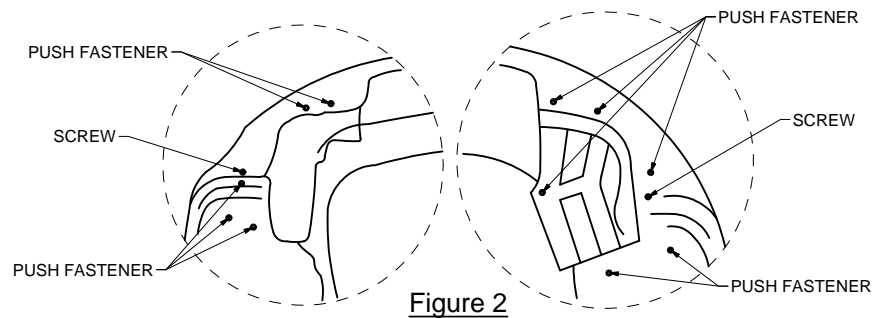
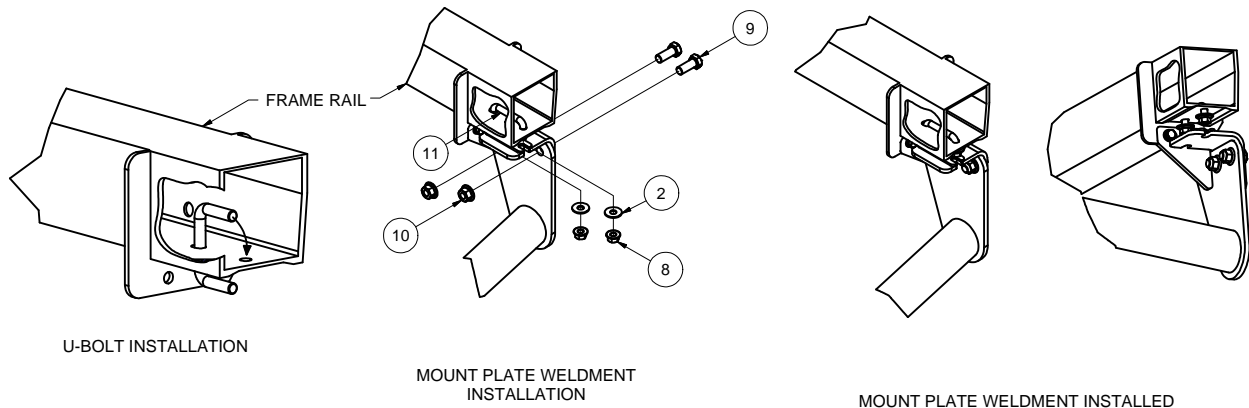

Figure 2



INSTALLATION STEPS

1. Remove the rear splash guards from driver and passenger side of vehicle. Keep the splash guards and fasteners for reinstallation in Step 13. (See Figure 1)
2. Remove the underbody panels by removing the (2) bolts and (11) push fasteners. Save the panels for reinstallation in Steps 11 and 12. (See Figure 2)
3. Remove the tow hook from driver side frame rail by removing the (4) bolts securing it. Return the tow hook and bolts to the vehicle owner.
4. Remove the (2) M8 bolts from the bottom of the flange on the passenger side frame rail. Return the bolts to the vehicle owner.
5. Raise the hitch into position and install the (4) M10 hex bolts with 3/8" conical toothed washers and (2) M12 hex bolts with 1/2" conical toothed washers into the driver side frame rail as shown on Page 1.
6. Secure the passenger side to the frame rail using (2) M8 hex bolts with 5/16" lock and flat washers in the position the bolts were removed from in Step 4 as shown. Also, install a M12 hex bolt with a 1/2" conical toothed washer as shown in the forwardmost hole.
7. Install the u-bolt into the frame rail as shown. (See U-Bolt Installation)
8. Attach the mount plate weldment to the passenger side plate using (2) 1/2-13 bolts and hex flange nuts as shown.
9. Secure the mount plate weldment to the frame rail using (2) conical toothed washers and 3/8" hex nuts as shown.
10. Torque Hardware: M8 to 23 ft-lbs; M10 to 45 ft-lbs; M12 to 79 ft-lbs; 1/2-13 to 110 ft-lbs
11. Reinstall the driver side underbody panel. (No modifications are required.)
12. Trim and reinstall the passenger side underbody panel. (See Passenger Side Underbody Panel Trim Diagram on Page 1)
13. Reinstall splash guards removed in Step 1.

PERIODICALLY CHECK THIS RECEIVER HITCH TO ENSURE THAT ALL FASTENERS ARE TIGHT AND THAT ALL STRUCTURAL COMPONENTS ARE SOUND.