

13563**NISSAN QUEST****5/26/2015**

**GROSS LOAD CAPACITY WHEN USED AS A WEIGHT CARRYING HITCH: 3,500 LBS. TRAILER WEIGHT & 300 LBS. TONGUE WEIGHT.
GROSS LOAD CAPACITY WHEN USED AS A WEIGHT DISTRIBUTION HITCH: 5,000 LBS. TRAILER WEIGHT & 500 LBS. TONGUE WEIGHT**

*****DO NOT EXCEED VEHICLE MANUFACTURER'S RECOMMENDED TOWING CAPACITY.*****

HAVING INSTALLATION QUESTIONS? CALL TECHNICAL SUPPORT AT 1-800-798-0813

Parts List			
ITEM	QTY	PART NUMBER	DESCRIPTION
1	6	1/2"	CONICAL TOOTHED WASHER
2	6	M12 - 1.25 x 40 HEX	HEX TAP BOLT

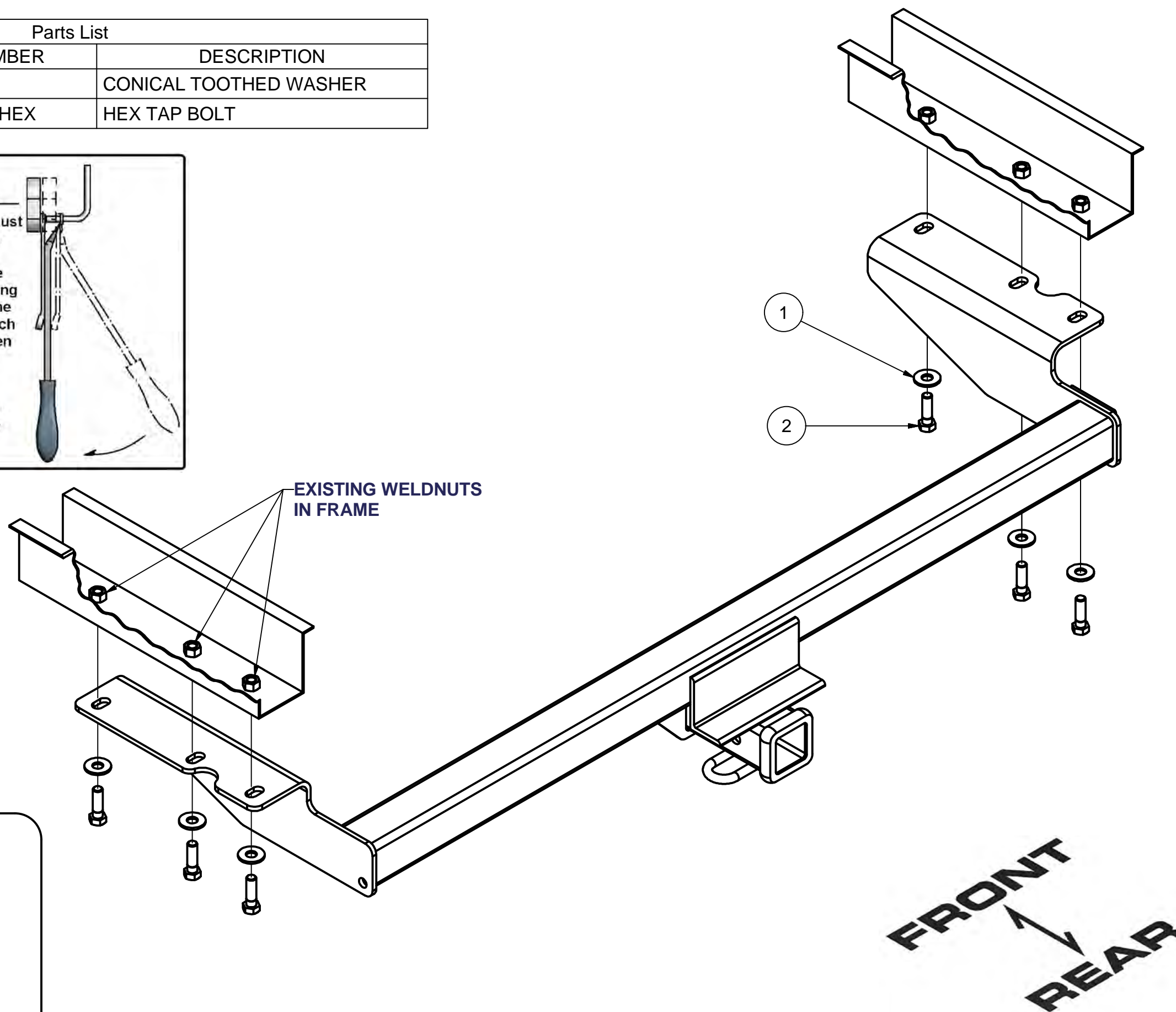
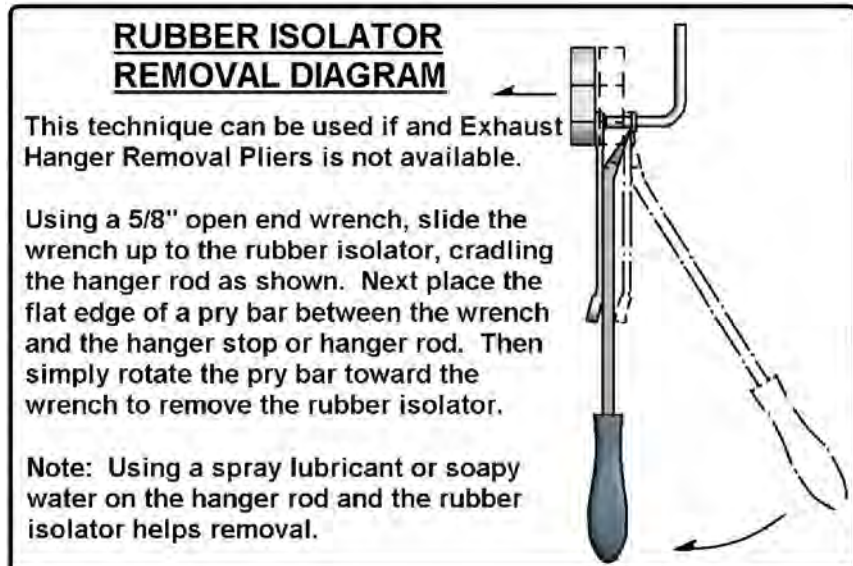

HITCH WEIGHT: 48 LBS.

INSTALL TIME

PROFESSIONAL: 25 MINUTES

NOVICE (DIY): 50 MINUTES

INSTALL NOTES:

- LOWER EXHAUST
- NO DRILLING REQ

INSTALLATION STEPS

1. Remove the plastic rivets that fasten the bumper fascia tabs to the back of vehicle. **(Note: To do this, remove the center of the rivet with a screwdriver, or from the top side, push down on the center piece in rivet and remove. Keep these rivets and put them back in after hitch is installed.)**
2. Lower the exhaust by removing the rubber from the muffler hanger and by loosening the two nuts that secure the exhaust hanger bracket to the chassis, ahead of the muffler adjacent to rear axle.
3. Pull and hold muffler to the side to remove the screw attaching the ground strap to the passenger side frame rail. Keep this screw. Remove the two screws that attach the aluminum heat shield to the frame. Return heat shield and screws to customer.
4. Raise hitch into place and loosely install the 12mm hex bolts and conical toothed washers. **(Note: Position hitch toward driver side to allow maximum muffler clearance.)**
5. Torque all 12mm fasteners to 86 lb.-ft.
6. Reinstall ground strap and screw. Lift exhaust back into position and re-install hangers.

PERIODICALLY CHECK THIS RECEIVER HITCH TO ENSURE THAT ALL FASTENERS ARE TIGHT AND THAT ALL STRUCTURAL COMPONENTS ARE SOUND.

Curt Manufacturing Inc., warrants this product to be free of defects in material and/or workmanship at the time of retail purchase by the original purchaser. If the product is found to be defective, Curt Manufacturing Inc., may repair or replace the product, at their option, when the product is returned, prepaid, with proof of purchase. Alteration to, misuse of, or improper installation of this product voids the warranty. Curt Manufacturing Inc.'s liability is limited to repair or replacement of products found to be defective, and specifically excludes liability for incidental or consequential loss or damage.