

13574**HONDA ELEMENT LX & EX**

10/22/2015

WILL NOT FIT SC MODEL

GROSS LOAD CAPACITY WHEN USED AS A WEIGHT CARRYING HITCH: 3500 LBS. TRAILER WEIGHT & 350 LBS. TONGUE WEIGHT.
*****DO NOT EXCEED VEHICLE MANUFACTURER'S RECOMMENDED TOWING CAPACITY.*****

Parts List			
ITEM	QTY	PART NUMBER	DESCRIPTION
1	2	1/2-13	HANDLE NUT
2	6	1/2"	WASHER
3	2	1/2-13 x 1 1/4	HEX BOLT
4	2	1/2-13 x 1 1/2	CARRIAGE BOLT
5	2	CM-SP19	.250 x 1.25 x 3.00" SQUARE HOLE SPACER
6	2	HFN 1213	HEX FLANGE NUT
7	1	7_16 - 14 x 1.75" x 1.00" C-C	U-BOLT
8	2	7/16-14	HEX FLANGE NUT
9	1	1_2 FISHWIRE	1/2" FISHWIRE

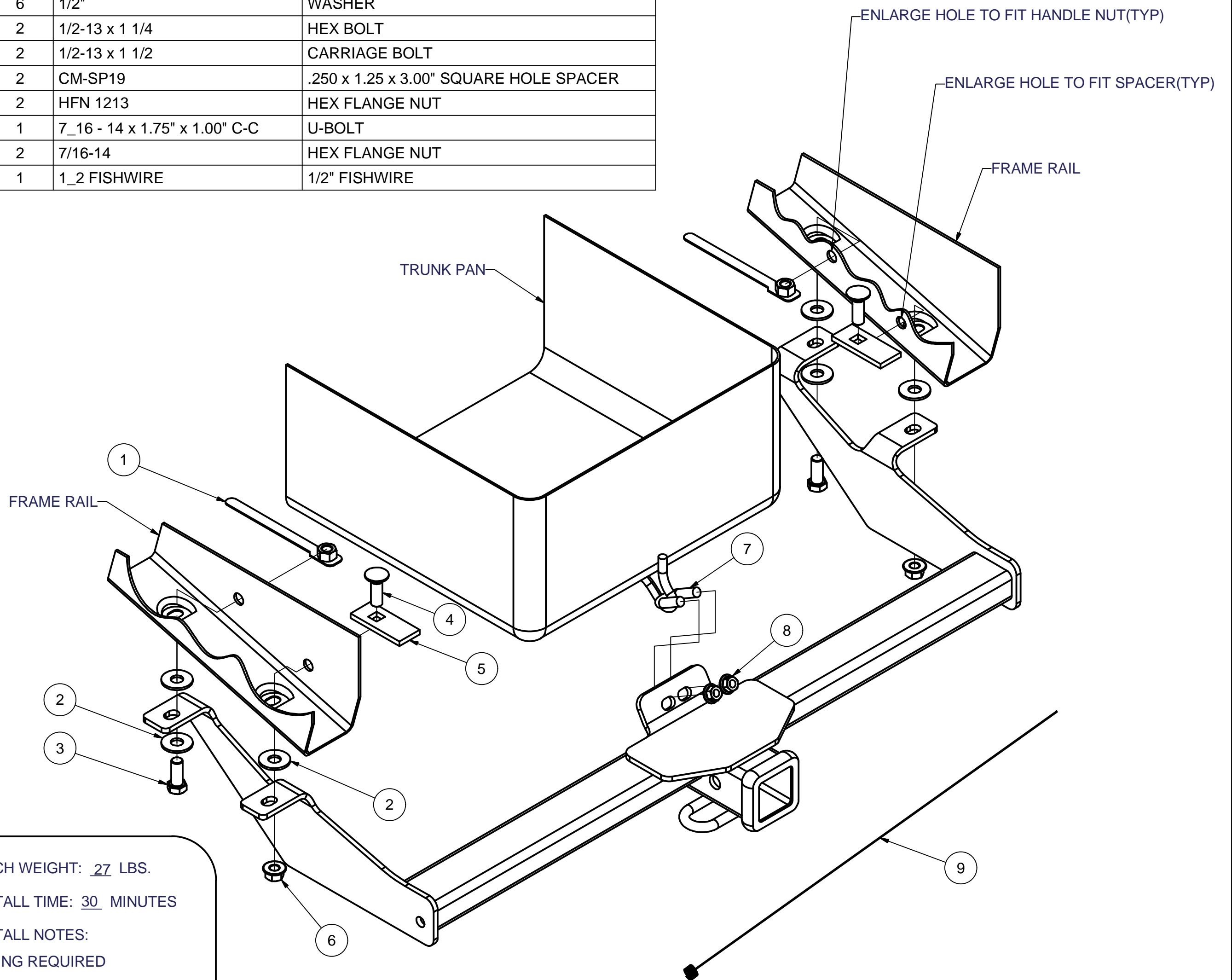

HITCH WEIGHT: 27 LBS.
 INSTALL TIME: 30 MINUTES
 INSTALL NOTES:
 -DRILLING REQUIRED

INSTALLATION STEPS

- 1) Enlarge holes in frame rails as shown.
- 2) Insert handle nut into hole as shown. Bending is required, handle end will stick out of existing frame rail hole.
- 3) Fishwire spacer through existing frame rail hole as shown.
- 4) Raise hitch into position and align holes.
- 5) Secure hitch to frame with remaining hardware.
- 6) Torque all 7/16" hardware to 50 lb-ft. and all 1/2" hardware to 110 lb-ft.

PERIODICALLY CHECK THIS RECEIVER HITCH TO ENSURE THAT ALL FASTENERS ARE TIGHT AND THAT ALL STRUCTURAL COMPONENTS ARE SOUND.

Curt Manufacturing Inc., warrants this product to be free of defects in material and/or workmanship at the time of retail purchase by the original purchaser. If the product is found to be defective, Curt Manufacturing Inc., may repair or replace the product, at their option, when the product is returned, prepaid, with proof of purchase. Alteration to, misuse of, or improper installation of this product voids the warranty. Curt Manufacturing Inc.'s liability is limited to repair or replacement of products found to be defective, and specifically excludes liability for incidental or consequential loss or damage.