

10/1/2012

GROSS LOAD CAPACITY WHEN USED AS A WEIGHT CARRYING HITCH: 5000 LBS. TRAILER WEIGHT & 500 LBS. TONGUE WEIGHT.  
 GROSS LOAD CAPACITY WHEN USED AS A WEIGHT DISTRIBUTION HITCH: 8000 LBS. TRAILER WEIGHT & 800 LBS. TONGUE WEIGHT  
**\*\*\* DO NOT EXCEED VEHICLE MANUFACTURER'S RECOMMENDED TOWING CAPACITY. \*\*\***

Parts List				
ITEM	QTY	PART NUMBER	DESCRIPTION	
1	1	1/2"	FISHWIRE TOOL	
2	4	M12 x 1.25 x 45	HEX BOLT	
3	6	HFN 1213	HEX FLANGE NUT	
4	2	1/2 - 13 x 1 1/2	HEX BOLT	
5	6	1/2"	CONICAL TOOTHED WASHER	
6	4	CM-SP33	.250 x 1.50 x 2.00" SQUARE HOLE SPACER	
7	4	1/2-13 x 1 3/4	CARRIAGE BOLT	

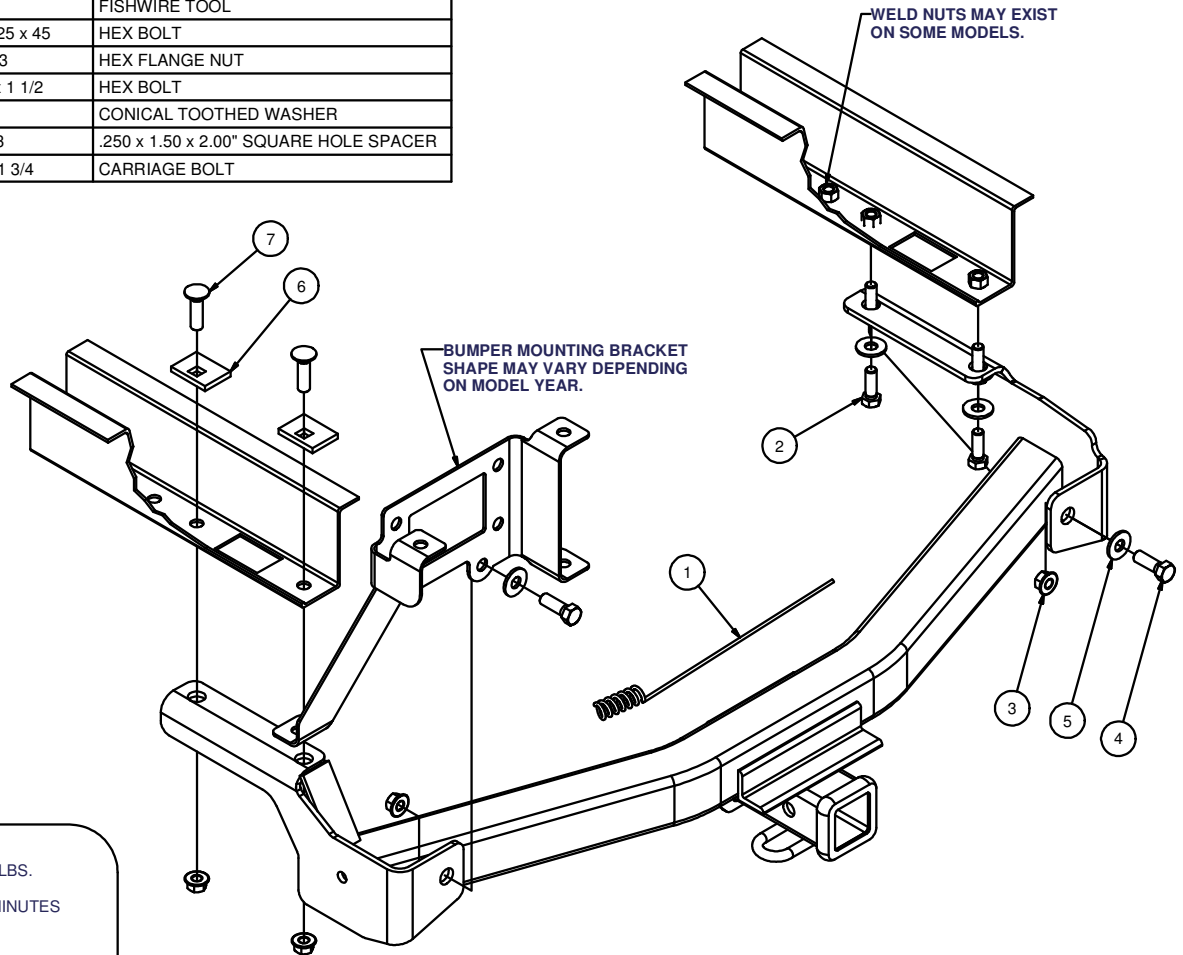

HITCH WEIGHT: 41 LBS.

INSTALL TIME: 30 MINUTES

INSTALL NOTES:

No drilling required, fishwire fasteners into place.

## INSTALLATION STEPS

**Caution:** Wiring harness is located inside passenger side frame rail, do not sandwich wires between frame rail and fasteners.

**Note:** If vehicle has a heat shield, remove one screw from the bottom of the frame rail so that models with bracket will mount flat.

- 1) Fishwire fasteners through access hole on underside of each frame rail. (**Note: Vehicles with weldnuts in frame use the M12 hex bolts and conical washers provided.**)
- 2) Raise hitch into position and install remaining fasteners through bumper mounting bracket as shown above.
- 3) Torque all 12 mm fasteners to 86 lb.-ft. and all 1/2" fasteners to 110 lb-ft.

**PERIODICALLY CHECK THIS RECEIVER HITCH TO ENSURE THAT ALL FASTENERS ARE TIGHT AND THAT ALL STRUCTURAL COMPONENTS ARE SOUND.**

Curt Manufacturing Inc., warrants this product to be free of defects in material and/or workmanship at the time of retail purchase by the original purchaser. If the product is found to be defective, Curt Manufacturing Inc., may repair or replace the product, at their option, when the product is returned, prepaid, with proof of purchase. Alteration to, misuse of, or improper installation of this product voids the warranty. Curt Manufacturing Inc.'s liability is limited to repair or replacement of products found to be defective, and specifically excludes liability for incidental or consequential loss or damage.