

13707

92-11 FORD CROWN VICTORIA
87-91 FORD COUNTRY SQUIRE
81-11 LINCOLN TOWN CAR
80-83 LINCOLN MARK VI

79-11 MERCURY GRAND MARQUIS SEDAN
79-82 MERCURY GRAND MARQUIS WAGON
03-04 MERCURY MARAUDER
79-82 MERCURY MONTEREY

7/12/2012

GROSS LOAD CAPACITY WHEN USED AS A WEIGHT CARRYING HITCH: 4,000 LBS. TRAILER WEIGHT & 400 LBS. TONGUE WEIGHT.
GROSS LOAD CAPACITY WHEN USED AS A WEIGHT DISTRIBUTION HITCH: 6,000 LBS. TRAILER WEIGHT & 600 LBS. TONGUE WEIGHT
DO NOT EXCEED VEHICLE MANUFACTURER'S RECOMMENDED TOWING CAPACITY.

Parts List			
ITEM	QTY	PART NUMBER	DESCRIPTION
1	1	CM-500-FW	FISHWIRE TOOL
2	4	HFN 1213	HEX FLANGE NUT
3	2	CM-SP38	1/2" WEDGE SPACER
4	10	CM-SP1	.250 x 1.50 x 2.00" SQUARE HOLE SPACER
5	4	1/2 - 13 x 2 1/4	CARRIAGE BOLT
6	1	5/16-18	HEX FLANGE NUT
7	4	5/16"	WASHER
8	1	5/16-18 x 1 1/4	HEX TAP BOLT

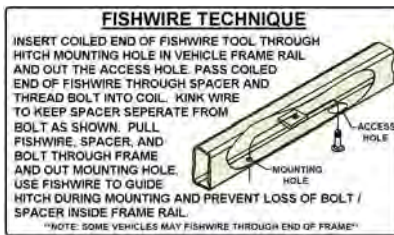
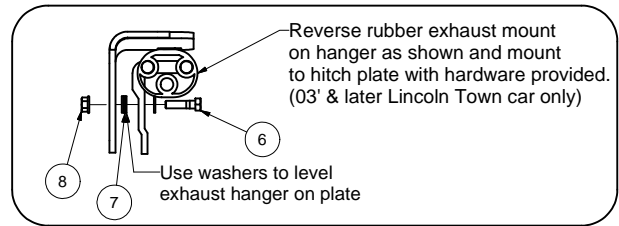

NOTE:
FOR MODELS WITH **DUAL EXHAUST** RELOCATION OF EXHAUST PIPE HANGER REQUIRED TO PROVIDE EXHAUST PIPE CLEARANCE

USE WEDGE SPACER PROVIDED AT THIS LOCATION WHEN INSTALLING HITCH ON WAGON APPLICATIONS

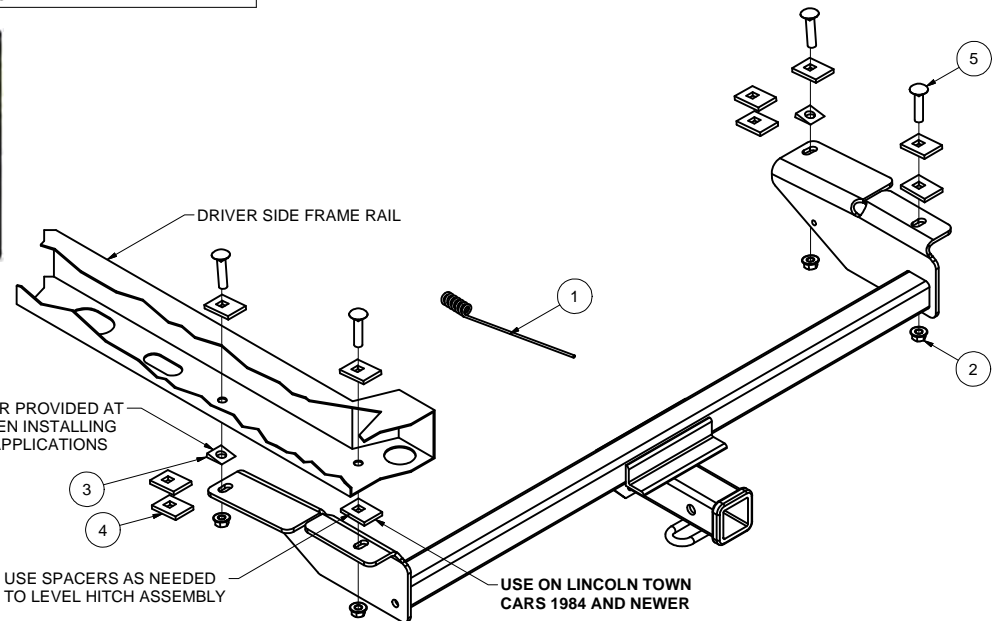

USE SPACERS AS NEEDED TO LEVEL HITCH ASSEMBLY

HITCH WEIGHT: 38 LBS.

INSTALL TIME: 45 MINUTES

INSTALL NOTES:

DRILLING REQUIRED

INSTALLATION STEPS

Notes: 1995, 2003 & later Lincoln Town car external dress panel beneath vehicle must be removed for hitch installation and returned to vehicle owner. 2003 & later Lincoln Town car requires the relocation of passenger side exhaust hanger bracket. The exhaust hanger bracket must be removed from the vehicle frame and rubber mount. With parts separated rotate bumper hanger and reattach to hanger bracket as shown. Attach hanger assembly to hitch mounting plate and exhaust after completing hitch installation.

- 1) Remove all but a thin film of undercoating from the frame at the hitch mounting location. The attaching surfaces must be free of weld spatter and other objects that could prevent the hitch from being mounted flat to the frame.
- 2) Raise hitch into position on frame rails making sure that it is centered on the vehicle. The hitch should be positioned so that the mounting plates are approximately 1" from the end of the frame. Using the hitch as a template drill four holes in the frame. The holes required near the bumper should be drilled as close to the center of the vehicle as possible.
- 3) Fishwire carriage bolts and blocks into mounting locations.
- 4) Install spacers between vehicle frame and hitch as needed to level hitch assembly. Wagon applications will require the use of provided wedge block spacer. 1984 and later Lincoln Town car requires the use of two spacer blocks at mounting locations near the bumper and one spacer block at the forward mounting locations.
- 5) With proper spacers placed between hitch and frame attach flange nuts to all mounting bolts.
- 6) If required attach exhaust hanger bracket to passenger side mounting plate using hardware provided. Use washers as needed to level exhaust hanger on mounting plate.
- 7) Torque all 1/2" hardware to 110 lb-ft.

PERIODICALLY CHECK THIS RECEIVER HITCH TO ENSURE THAT ALL FASTENERS ARE TIGHT AND THAT ALL STRUCTURAL COMPONENTS ARE SOUND.

Curt Manufacturing Inc., warrants this product to be free of defects in material and/or workmanship at the time of retail purchase by the original purchaser. If the product is found to be defective, Curt Manufacturing Inc., may repair or replace the product, at their option, when the product is returned, prepaid, with proof of purchase. Alteration to, misuse of, or improper installation of this product voids the warranty. Curt Manufacturing Inc.'s liability is limited to repair or replacement of products found to be defective, and specifically excludes liability for incidental or consequential loss or damage.