

14029

92-00 CHEV/GMC SUBURBAN, YUKON, TAHOE,
99-02 ESCALADE, 92-96 CHEVY FULL SIZE BLAZER

6/13/2012

GROSS LOAD CAPACITY WHEN USED AS A WEIGHT CARRYING HITCH: 10,000 LBS. TRAILER WEIGHT & 1,000 LBS. TONGUE WEIGHT.
GROSS LOAD CAPACITY WHEN USED AS A WEIGHT DISTRIBUTION HITCH: 12,000 LBS. TRAILER WEIGHT & 1,200 LBS. TONGUE WEIGHT
***** DO NOT EXCEED VEHICLE MANUFACTURER'S RECOMMENDED TOWING CAPACITY.*****

Parts List			
ITEM	QTY	PART NUMBER	DESCRIPTION
1	6	CM-SP1	.250 x 1.50 x 2.00" SQUARE HOLE SPACER
2	6	HFN 1213	HEX FLANGE NUT
3	1	1/2"	FISHWIRE TOOL
4	6	1/2-13 x 1 3/4	CARRIAGE BOLT

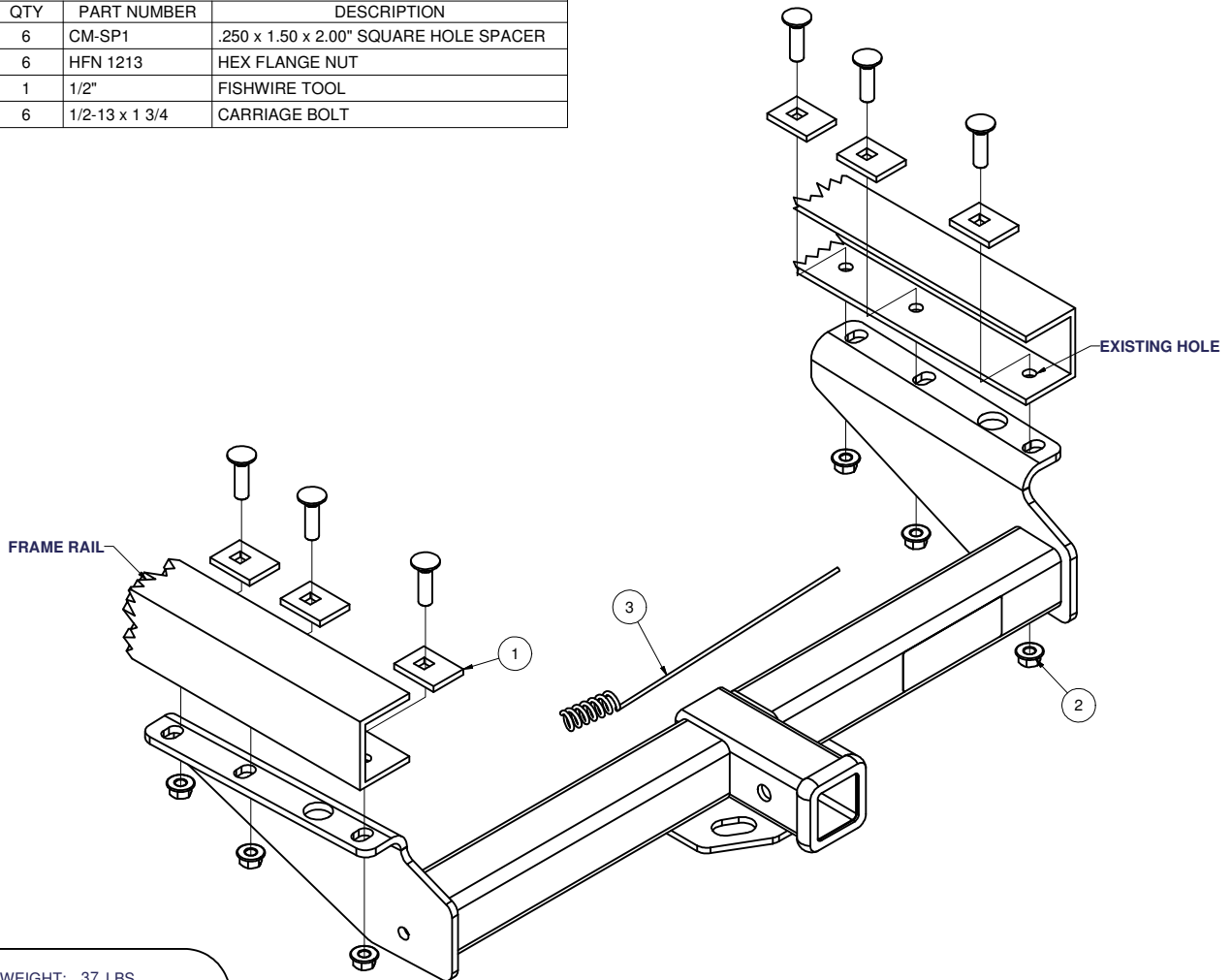

HITCH WEIGHT: 37 LBS.

INSTALL TIME: 30 MINUTES

INSTALL NOTES:

ENLARGE EXISTING HOLES TO 1/2"

INSTALLATION STEPS

- 1) Install fasteners as shown. Some models may require mounting hole to be reamed out to 1/2".
- 2) Installations on boxed-in frames will be made easier by fishwiring the bolts and spacers into the holes from an existing access hole. Wrap a wire around the threads of the bolt at the end and pull wire, bolt, and spacers back through the access hole through the attachment hole.
- 3) Raise the hitch into position, taking care not to push bolts back into frame. The large slot on each side fits over the rivet. Secure each bolt with a flange nut.
- 4) Torque all hardware to 110 lb.-ft.

PERIODICALLY CHECK THIS RECEIVER HITCH TO ENSURE THAT ALL FASTENERS ARE TIGHT AND THAT ALL STRUCTURAL COMPONENTS ARE SOUND.

Curt Manufacturing Inc., warrants this product to be free of defects in material and/or workmanship at the time of retail purchase by the original purchaser. If the product is found to be defective, Curt Manufacturing Inc., may repair or replace the product, at their option, when the product is returned, prepaid, with proof of purchase. Alteration to, misuse of, or improper installation of this product voids the warranty. Curt Manufacturing Inc.'s liability is limited to repair or replacement of products found to be defective, and specifically excludes liability for incidental or consequential loss or damage.