

# 14082 / RRH14082

73-06 CHEVROLET/GM ALL FULL SIZE W/34" FRAME, 62-73 CHEVROLET/GM FULL SIZE, 73-79 FORD F-250 CREW CAB & 73-97 FORD F-350 W/34" FRAME

2/15/13

GROSS LOAD CAPACITY WHEN USED AS A WEIGHT CARRYING HITCH: 10,000 LBS. TRAILER WEIGHT & 1,000 LBS. TONGUE WEIGHT.  
GROSS LOAD CAPACITY WHEN USED AS A WEIGHT DISTRIBUTION HITCH: 12,000 LBS. TRAILER WEIGHT & 1,200 LBS. TONGUE WEIGHT

**\*\*\*DO NOT EXCEED VEHICLE MANUFACTURER'S RECOMMENDED TOWING CAPACITY.\*\*\***

| Parts List |     |               |  |
|------------|-----|---------------|--|
| ITEM       | QTY | PART NUMBER   | DESCRIPTION                            |
| 1          | 6   | 1/2 - 13 x 2" | CARRIAGE BOLT                          |
| 2          | 6   | HFN 1213      | HEX FLANGE NUT                         |
| 3          | 12  | CM-SP1        | .250 x 1.50 x 2.00" SQUARE HOLE SPACER |

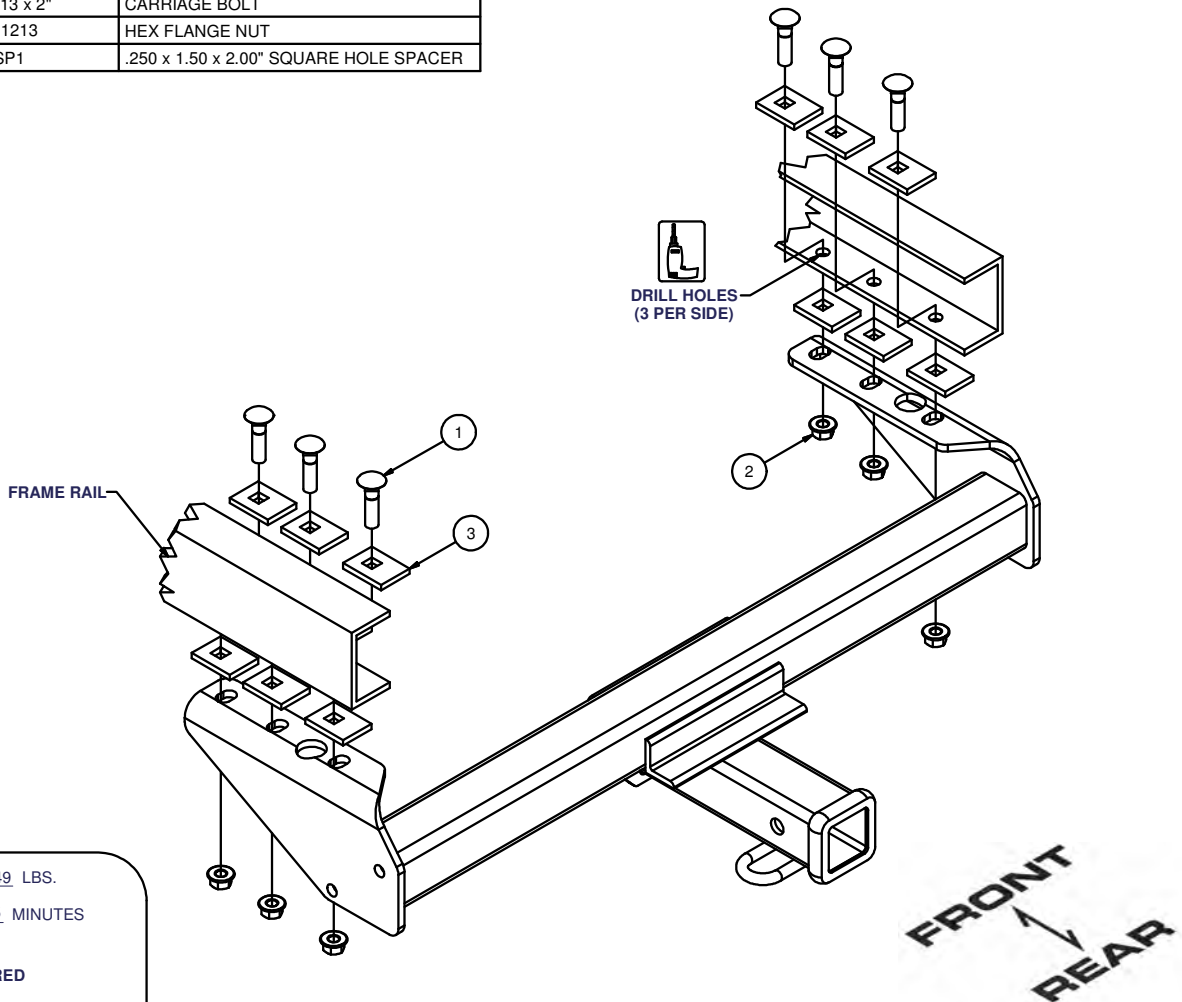

HITCH WEIGHT: 49 LBS.

INSTALL TIME: 45 MINUTES

INSTALL NOTES:

**DRILLING REQUIRED**

## INSTALLATION STEPS

- 1) Prepare the vehicle frame, remove the spare tire and rear bolt of spare tire holder. Clean away any mud and most of the undercoating if present.
- 2) Position the hitch onto the frame, (help may be required to hold the receiver in position while marking the mounting holes). Position the receiver so that the receiver tube extends approximately even with the end of the vehicle. A square hole spacer should be used between the side plates and the frame to clear rivets. Using the receiver as a template, mark the six holes to be drilled for mounting the receiver.
- 3) Drill the mounting holes, CAUTION - Always use proper eye protection when operating a drill. Check the frame of the vehicle to be sure no wires or hoses will be damaged while drilling the mounting holes. Drill all mounting holes with 1/2" drill bit.
- 4) Attach receiver to vehicle frame as shown.
- 5) Torque all mounting hardware to 110 lb.-ft.

**PERIODICALLY CHECK THIS RECEIVER HITCH TO ENSURE THAT ALL FASTENERS ARE TIGHT AND THAT ALL STRUCTURAL COMPONENTS ARE SOUND.**

Curt Manufacturing Inc., warrants this product to be free of defects in material and/or workmanship at the time of retail purchase by the original purchaser. If the product is found to be defective, Curt Manufacturing Inc., may repair or replace the product, at their option, when the product is returned, prepaid, with proof of purchase. Alteration to, misuse of, or improper installation of this product voids the warranty. Curt Manufacturing Inc.'s liability is limited to repair or replacement of products found to be defective, and specifically excludes liability for incidental or consequential loss or damage.