

15325

1988 - 2000 CHEVROLET / GMC FULL SIZE PICKUPS,
LONG & SHORT BED, OLD BODY STYLE

10/3/2012

SHEET 1 of 2

GROSS LOAD CAPACITY WHEN USED AS A WEIGHT CARRYING HITCH: 16,000 LBS. TRAILER WEIGHT & 2,400 LBS. TONGUE WEIGHT.
GROSS LOAD CAPACITY WHEN USED AS A WEIGHT DISTRIBUTION HITCH: 17,000 LBS. TRAILER WEIGHT & 2,400 LBS. TONGUE WEIGHT

DO NOT EXCEED VEHICLE MANUFACTURER'S RECOMMENDED TOWING CAPACITY.

HAVING INSTALLATION QUESTIONS? CALL TECHNICAL SUPPORT AT 1-800-798-0813

Parts List			
ITEM	QTY	PART NUMBER	DESCRIPTION
1	4	1/2-13 x 1 3/4	CARRIAGE BOLT
2	2	CM-SP1	.250 x 1.50 x 2.00" SQUARE HOLE SPACER
3	2	CM-SP4	.250 x 1.50 x 3.00" SQUARE HOLE SPACER
4	8	1/2-13 x 1 1/2	CARRIAGE BOLT
5	12	HFN 1213	HEX FLANGE NUT
6	2	M12 - 1.75 x 50mm	HEX BOLT
7	2	1/2	CONICAL TOOTHED WASHER
8	2	CM-SP22	.250 x 1.50 x 1.50" ROUND HOLE SPACER
9	2	M12-1.75	HEX FLANGE NUT

TOOLS REQUIRED
RATCHET
TORQUE WRENCH
12" SOCKET EXTENSION
3/4" SOCKET
18mm SOCKET

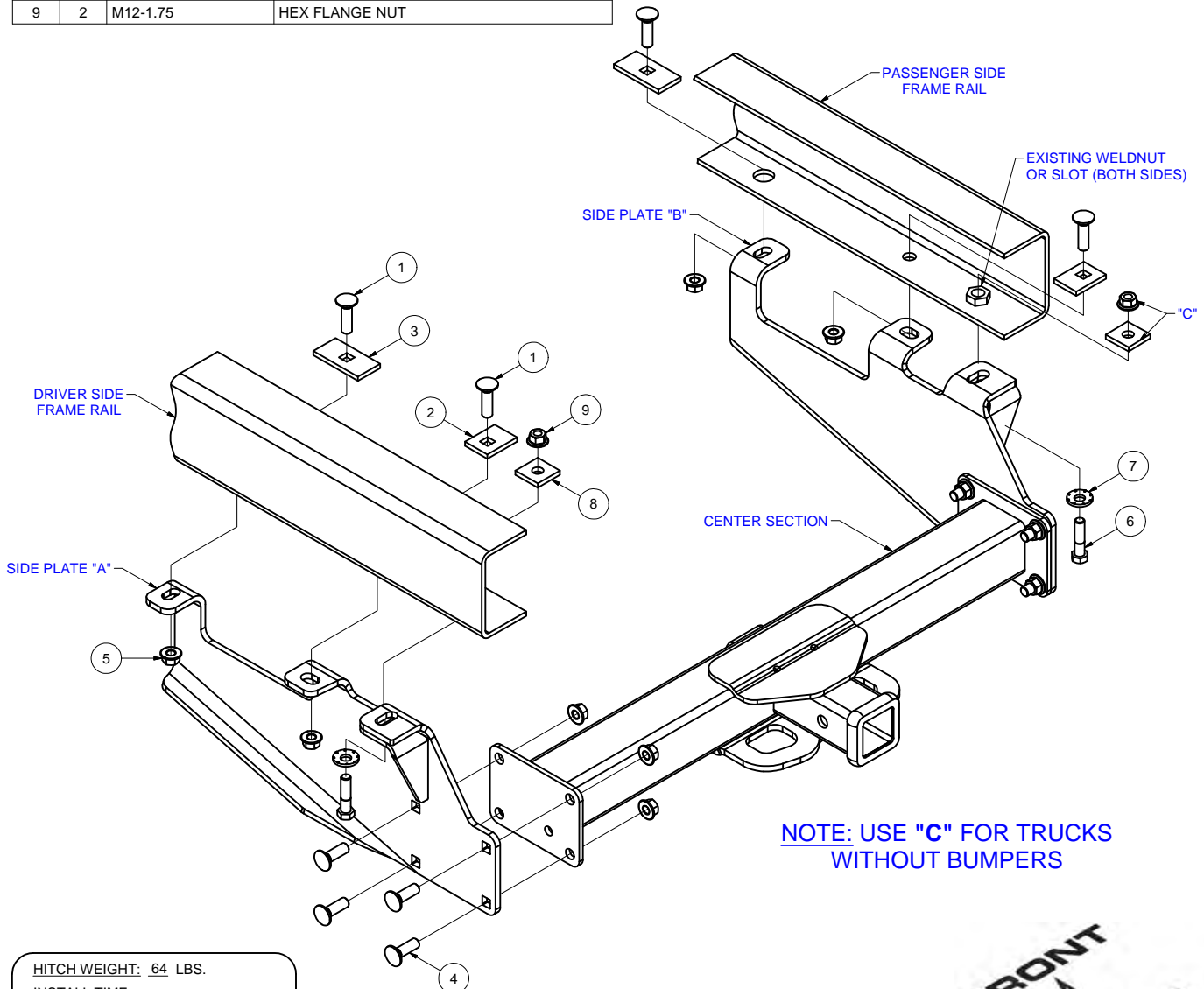
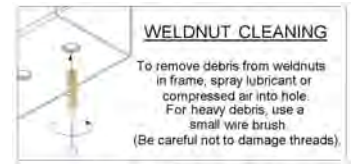

NOTE: USE "C" FOR TRUCKS WITHOUT BUMPERS



HITCH WEIGHT: 64 LBS.

INSTALL TIME

PROFESSIONAL: 30 MINUTES

NOVICE (DIY): 60 MINUTES

INSTALL NOTES:

- NO DRILLING REQUIRED
- LOWER SPARE TIRE

PERIODICALLY CHECK THIS RECEIVER HITCH TO ENSURE THAT ALL FASTENERS ARE TIGHT AND THAT ALL STRUCTURAL COMPONENTS ARE SOUND.

Curt Manufacturing LLC., warrants this product to be free of defects in material and/or workmanship at the time of retail purchase by the original purchaser. If the product is found to be defective, Curt Manufacturing LLC., may repair or replace the product, at their option, when the product is returned, prepaid, with proof of purchase. Alteration to, misuse of, or improper installation of this product voids the warranty. Curt Manufacturing LLC.'s liability is limited to repair or replacement of products found to be defective, and specifically excludes liability for incidental or consequential loss or damage.

15325

**1988 - 2000 CHEVROLET / GMC FULL SIZE PICKUPS,
LONG & SHORT BED, OLD BODY STYLE**

SHEET 2 of 2

**GROSS LOAD CAPACITY WHEN USED AS A WEIGHT CARRYING HITCH: 16,000 LBS. TRAILER WEIGHT & 2,400 LBS. TONGUE WEIGHT.
GROSS LOAD CAPACITY WHEN USED AS A WEIGHT DISTRIBUTION HITCH: 1,700 LBS. TRAILER WEIGHT & 17,000 LBS. TONGUE WEIGHT**

*****DO NOT EXCEED VEHICLE MANUFACTURER'S RECOMMENDED TOWING CAPACITY.*****

HAVING INSTALLATION QUESTIONS? CALL TECHNICAL SUPPORT AT 1-800-798-0813

INSTALLATION STEPS

NOTE: Determine which installation method will work best for you, instructions "A" or "B".

Instructions "A"

1. Lower and remove spare tire for ease of installation. Spare will be put back in place after hitch is installed.
2. Bolt the center section to side plates "A" and "B" with the 1/2" x 1 1/2" carriage bolts and 1/2"-13 hex flange nuts, as shown.
3. If the vehicle is equipped with a factory installed bumper, remove the 12mm bumper bracket bolts from both sides and move on to step (4a). If no bumper is installed move on to step (4b).
4. a) Raise hitch into position aligning the rearmost holes in the side plates with the holes in each frame rail where the 12mm bolts were removed in step (3). Loosely secure hitch in place using 12mm bolts and conical toothed washers with existing weldnuts, as shown. (Bolts will be tightened in step 7.)

b) Raise hitch into position aligning the rearmost holes in the side plates with the rearmost slots in the frame rails. Loosely secure hitch in place using 12mm bolts, conical toothed washers, 12mm flange nuts and SP-22 spacers, as shown. (Bolts will be tightened in step 7.)
5. Place a 1/2"-13 x 1 3/4" carriage bolt along with a CM-SP4 spacer in the forwardmost hole in the frame rail (one each side). Secure with a 1/2"-13 hex flange nut, as shown.
6. Place a 1/2"-13 x 1 3/4" carriage bolt along with a CM-SP1 spacer in the center holes in the frame rail (one each side). Secure with a 1/2"-13 hex flange nut, as shown.
7. Torque all 1/2" hardware to 110 ft-lbs and 12mm hardware to 79 ft-lbs.
8. Reinstall spare tire removed in step 1.

Instructions "B"

1. Lower and remove spare tire for ease of installation. Spare will be put back in place after hitch is installed.
2. If the vehicle is equipped with a factory installed bumper, remove the 12mm bumper bracket bolts from both sides and move on to step (3a). If no bumper is installed move on to step (3b).
3. a) Raise side plates "A" and "B" into position aligning the rearmost holes with the holes in each frame rail where the 12mm bolts were removed in step (2). Loosely secure side plates using 12mm bolts and conical toothed washers with existing weldnuts, as shown. (Bolts will be tightened in step 7.)

b) Raise side plates "A" and "B" into position aligning the rearmost holes in the side plates with the rearmost slots in the frame rails. Loosely secure side plates using 12mm bolts and conical toothed washer with 12mm flange nuts and SP-22 spacers, as shown. (Bolts will be tightened in step 7.)
4. Place a 1/2"-13 x 1 3/4" carriage bolt along with a CM-SP4 spacer in the forwardmost hole in the frame rail (one each side). Loosely secure with a 1/2"-13 hex flange nut, as shown. (Bolts will be tightened in step 7.)
5. Place a 1/2"-13 x 1 3/4" bolt along with a CM-SP1 spacer in the center holes in the frame rail (one each side). Loosely Secure with a 1/2"-13 hex flange nut, as shown. (Bolts will be tightened in step 7.)
6. Raise the receiver tube assembly into position and secure the center section to side plates "A" and "B" with the 1/2" -13 x 1 1/2" carriage bolts and 1/2"-13 hex flange nuts, as shown.
7. Center hitch on vehicle and torque all 1/2" hardware to 110 ft-lbs and 12mm hardware to 79 ft-lbs.
8. Reinstall spare tire removed in step 1.

**PERIODICALLY CHECK THIS RECEIVER HITCH TO ENSURE THAT ALL FASTENERS
ARE TIGHT AND THAT ALL STRUCTURAL COMPONENTS ARE SOUND.**

Curt Manufacturing LLC., warrants this product to be free of defects in material and/or workmanship at the time of retail purchase by the original purchaser. If the product is found to be defective, Curt Manufacturing LLC., may repair or replace the product, at their option, when the product is returned, prepaid, with proof of purchase. Alteration to, misuse of, or improper installation of this product voids the warranty. Curt Manufacturing LLC.'s liability is limited to repair or replacement of products found to be defective, and specifically excludes liability for incidental or consequential loss or damage.