

15445**1999-CURRENT FORD F350, F450, F-550, F-650****9/18/2017**

**GROSS LOAD CAPACITY WHEN USED AS A WEIGHT CARRYING HITCH: 17,000 LBS. TRAILER WEIGHT & 2,550 LBS. TONGUE WEIGHT.
GROSS LOAD CAPACITY WHEN USED AS A WEIGHT DISTRIBUTION HITCH: 17,000 LBS. TRAILER WEIGHT & 2,550 LBS. TONGUE WEIGHT**

*****DO NOT EXCEED VEHICLE MANUFACTURER'S RECOMMENDED TOWING CAPACITY.*****

HAVING INSTALLATION QUESTIONS? CALL TECHNICAL SUPPORT AT 1-800-798-0813

Parts List			
ITEM	QTY	PART NUMBER	DESCRIPTION
1	2	CM-SP142	.313" SPACER
2	4	CM-SP1	.250 x 1.50 x 2.00" SQUARE HOLE SPACER
3	10	HFN 1213	HEX FLANGE NUT
4	4	1/2-13 x 1 3/4	CARRIAGE BOLT
5	6	1/2-13 x 1 1/2	CARRIAGE BOLT

TOOLS REQUIRED
RATCHET
TORQUE WRENCH
3/4" SOCKET
DRILL
17/32" DRILL BIT

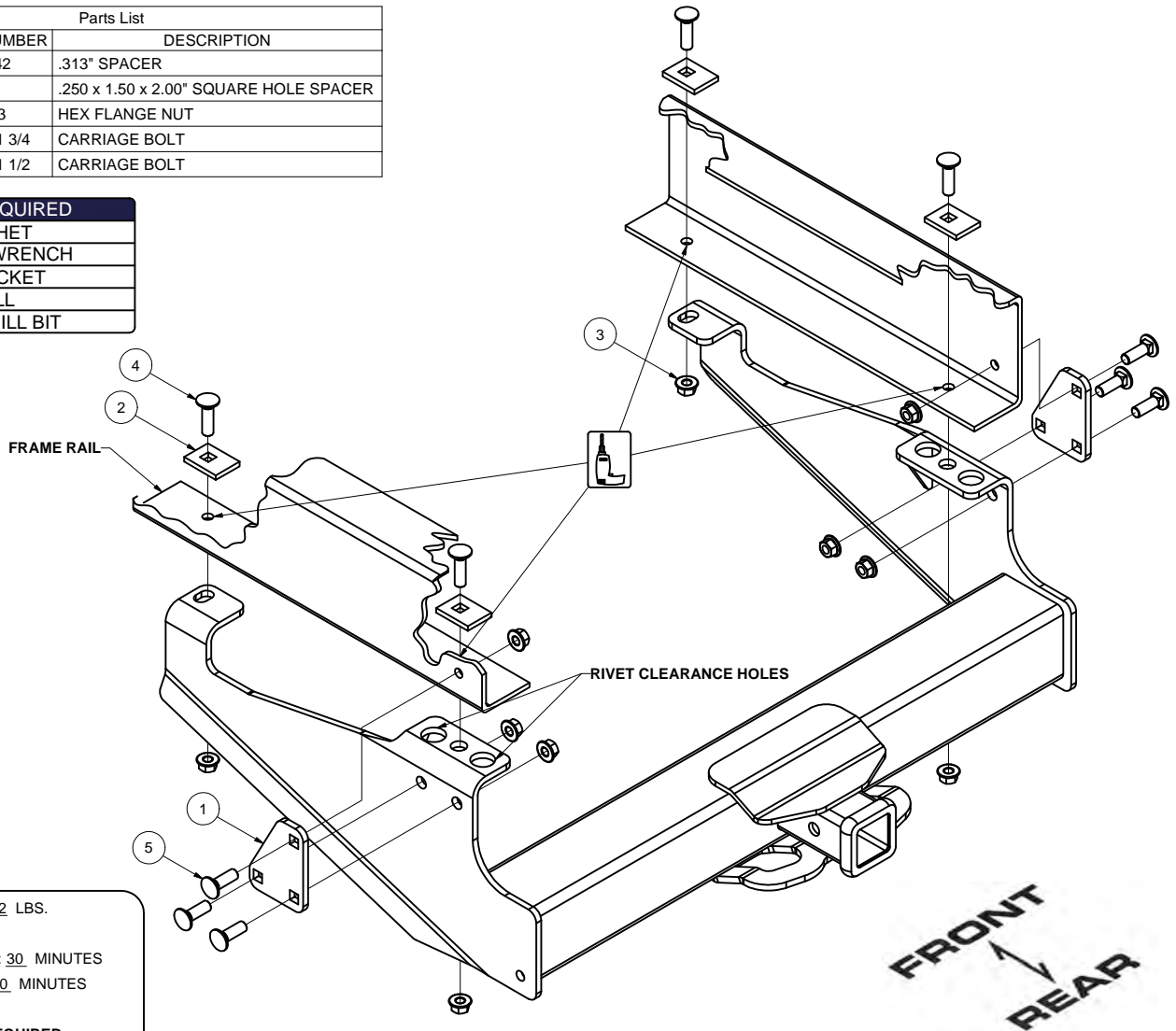

HITCH WEIGHT: 72 LBS.

INSTALL TIME

PROFESSIONAL: 30 MINUTES

NOVICE (DIY): 60 MINUTES

INSTALL NOTES:

- DRILLING REQUIRED

INSTALLATION STEPS

Warning: When drilling the hitch mounting holes, use a metal or wood shield between the frame and fuel tank, fuel filler hose or electrical wires to prevent damage when the frame is drilled through.

1. Raise hitch into position and clamp in place. Use the rivet clearance holes in the side plates for proper alignment.
2. With the hitch in place, mark the hole furthest from the bumper, for drilling. When you have the drill location marked, use a 17/32" drill bit to make the required mounting hole.
3. Fasten the hitch to the frame as shown, fastening to the drilled holes in the back of the frame first and then to the drilled holes in the front.
4. Attach the mounting plates to the hitch and fasten to the truck as shown.
5. Torque all hardware to 110 ft-lbs.

PERIODICALLY CHECK THIS RECEIVER HITCH TO ENSURE THAT ALL FASTENERS ARE TIGHT AND THAT ALL STRUCTURAL COMPONENTS ARE SOUND.

Curt Manufacturing LLC., warrants this product to be free of defects in material and/or workmanship at the time of retail purchase by the original purchaser. If the product is found to be defective, Curt Manufacturing LLC., may repair or replace the product, at their option, when the product is returned, prepaid, with proof of purchase. Alteration to, misuse of, or improper installation of this product voids the warranty. Curt Manufacturing LLC.'s liability is limited to repair or replacement of products found to be defective, and specifically excludes liability for incidental or consequential loss or damage.