

15661

CHEVROLET / GMC 2500 / 3500 (LONG BOX)

6/15/2012

GROSS LOAD CAPACITY WHEN USED AS A WEIGHT CARRYING HITCH: 18,000 LBS. TRAILER WEIGHT & 1,800 LBS. TONGUE WEIGHT.
 GROSS LOAD CAPACITY WHEN USED AS A WEIGHT DISTRIBUTION HITCH: 18,000 LBS. TRAILER WEIGHT & 1,800 LBS. TONGUE WEIGHT

DO NOT EXCEED VEHICLE MANUFACTURER'S RECOMMENDED TOWING CAPACITY.

HAVING INSTALLATION QUESTIONS? CALL TECHNICAL SUPPORT AT 1-800-798-0813

Parts List			
ITEM	QTY	PART NUMBER	DESCRIPTION
1	4	M14 - 2 x 45 HEX	HEX BOLT
2	4	9/16" CONICAL WASHER	CONICAL TOOTHED WASHER
3	4	1/2-13 x 1 3/4	CARRIAGE BOLT
4	4	CM-SP1	.250 x 1.50 x 2.00" SQUARE HOLE SPACER
5	4	HFN 1213	HEX FLANGE NUT

TOOLS REQUIRED
RATCHET
TORQUE WRENCH
10" EXTENSION
21mm SOCKET
3/4" SOCKET

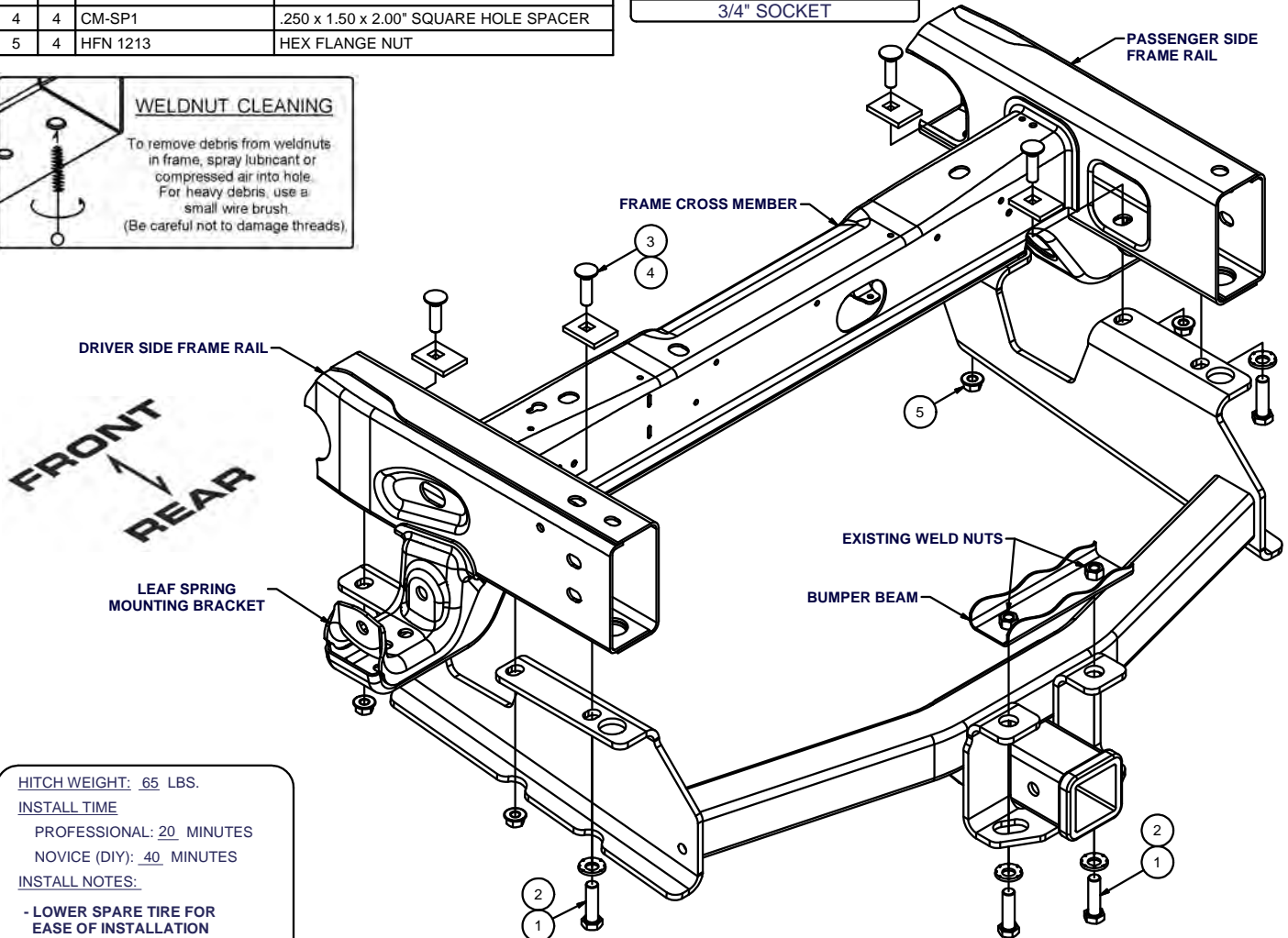
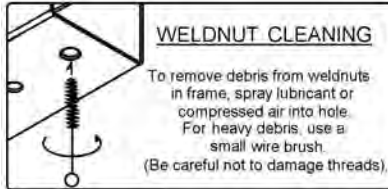

HITCH WEIGHT: 65 LBS.

INSTALL TIME

PROFESSIONAL: 20 MINUTES

NOVICE (DIY): 40 MINUTES

INSTALL NOTES:

- LOWER SPARE TIRE FOR EASE OF INSTALLATION
- NO DRILLING REQUIRED

INSTALLATION STEPS

1. Remove existing 14mm fasteners from end of each frame rail if present and return to customer. Lower spare tire from vehicle to ease installation.
2. Raise hitch into position, locating slots in hitch over weldnuts in vehicle frame.
3. Install 14mm bolts and conical toothed washers through hitch into weldnuts in vehicle frame and bumper. Install 1/2" carriage bolts, spacers, and nuts as shown above.
4. Torque all 14mm fasteners to 126 ft-lbs, and all 1/2" fasteners to 110 ft-lbs.
5. Raise spare back into position on vehicle.

PERIODICALLY CHECK THIS RECEIVER HITCH TO ENSURE THAT ALL FASTENERS ARE TIGHT AND THAT ALL STRUCTURAL COMPONENTS ARE SOUND.

Curt Manufacturing Inc., warrants this product to be free of defects in material and/or workmanship at the time of retail purchase by the original purchaser. If the product is found to be defective, Curt Manufacturing Inc., may repair or replace the product, at their option, when the product is returned, prepaid, with proof of purchase. Alteration to, misuse of, or improper installation of this product voids the warranty. Curt Manufacturing Inc.'s liability is limited to repair or replacement of products found to be defective, and specifically excludes liability for incidental or consequential loss or damage.