

# 15830

2001-2007 CHEVROLET SILVERADO 3500 CAB & CHASSIS (CLASSIC w/34" WIDE FRAMES)  
2001-2007 GMC SIERRA 3500 CAB & CHASSIS (CLASSIC w/34" WIDE FRAMES)  
2007-2009 CHEVROLET SILVERADO 3500 HD CAB & CHASSIS (NEW BODY STYLE w/34" WIDE FRAMES)  
2007-2009 GMC SIERRA 3500 HD CAB & CHASSIS (NEW BODY STYLE w/34" WIDE FRAMES)  
2007-2009 DODGE RAM 3500 HD CHASSIS CAB w/34" FRAMES  
2008-2009 DODGE RAM 4500/5500 HD CHASSIS CAB w/34" FRAMES

11/06/2012

GROSS LOAD CAPACITY WHEN USED AS A WEIGHT CARRYING HITCH: 20,000 LBS. TRAILER WEIGHT & 2,700 LBS. TONGUE WEIGHT.  
GROSS LOAD CAPACITY WHEN USED AS A WEIGHT DISTRIBUTION HITCH: 20,000 LBS. TRAILER WEIGHT & 2,700 LBS. TONGUE WEIGHT

\*\*\*DO NOT EXCEED VEHICLE MANUFACTURER'S RECOMMENDED TOWING CAPACITY.\*\*\*

HAVING INSTALLATION QUESTIONS? CALL TECHNICAL SUPPORT AT 1-800-798-0813

Parts List			
ITEM	QTY	PART NUMBER	DESCRIPTION
1	6	9_16-12 FLANGE NUT	HEX FLANGE NUT
2	6	9_16-12 x 1 3/4	CARRIAGE BOLT
3	6	CM-SP74	.250 x 1.50 x 3.00" 9/16" SQUARE HOLE SPACER

TOOLS REQUIRED
RATCHET
TORQUE WRENCH
7/8" SOCKET
DRILL
19/32" DRILL BIT
CHISEL
GRINDER
CLAMPS
CENTER PUNCH

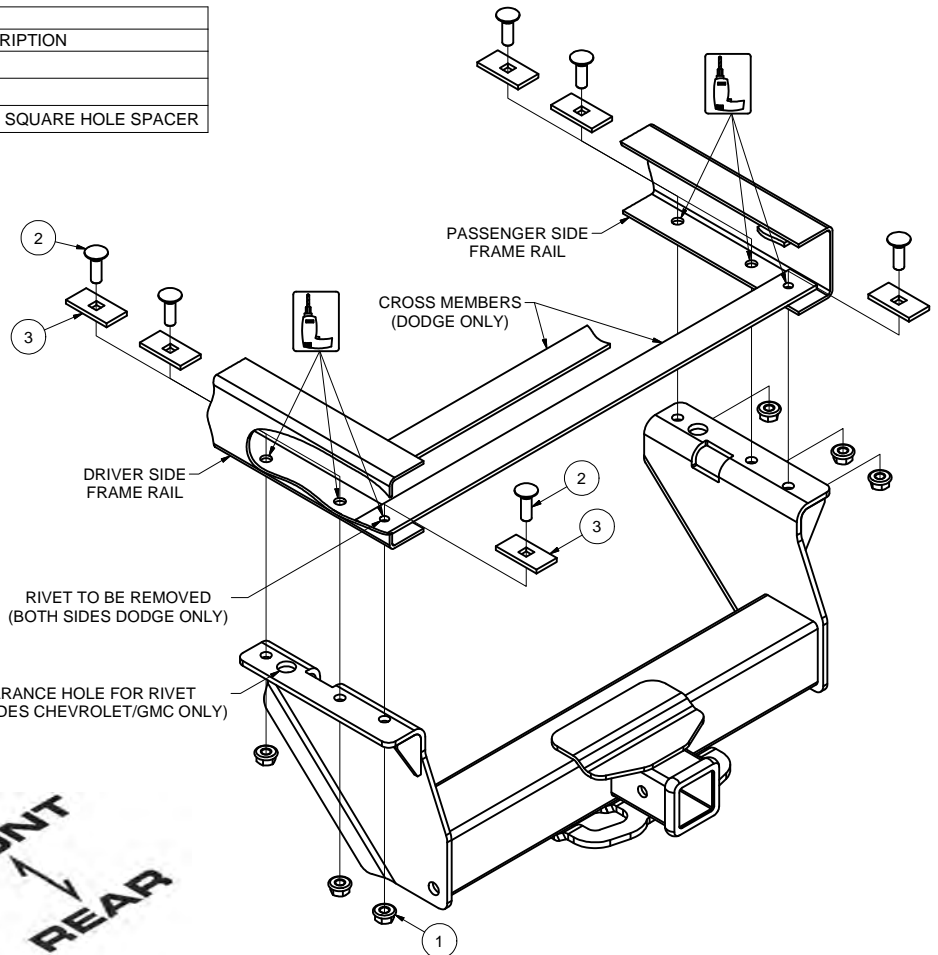
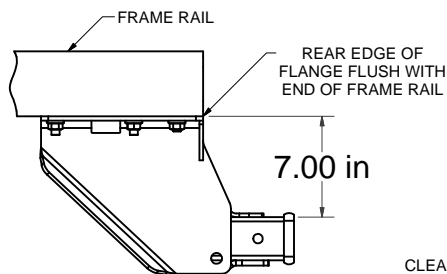

HITCH SHOWN IN PROPER POSITION

HITCH WEIGHT: 58 LBS.

INSTALL TIME

PROFESSIONAL: 30 MINUTES

NOVICE (DIY): 60 MINUTES

INSTALL NOTES:

- DRILLING REQUIRED



## INSTALLATION STEPS

### DODGE CHASSIS CAB

1. Remove rearmost rivet on bottom of frame rail, each side. (Rivet location will be enlarged in Step 3.)
2. Raise hitch into position, place rear edges of horizontal flanges flush with end of frame rails and clamp to frame rail.
3. Using hitch as a template, drill 3 holes on each side as shown.
4. Install carriage bolts and spacers through holes drilled in frame rails and out hitch side plates, as shown above. Secure with flange nuts.
5. Torque all 9/16" hardware to 150 ft-lbs.

### CHEVROLET/GMC CAB & CHASSIS

1. Raise hitch into position by aligning 1" diameter hole with the rivet on the bottom of the frame rail, on each side and clamp in place.
2. Using hitch as a template, drill (3) holes on each side as shown.
3. Install carriage bolts and spacers through holes drilled in frame rails and out hitch side plates, as shown above. Secure with flange nuts.
4. Torque all 9/16" hardware to 150 ft-lbs.

PERIODICALLY CHECK THIS RECEIVER HITCH TO ENSURE THAT ALL FASTENERS ARE TIGHT AND THAT ALL STRUCTURAL COMPONENTS ARE SOUND.

Curt Manufacturing LLC., warrants this product to be free of defects in material and/or workmanship at the time of retail purchase by the original purchaser. If the product is found to be defective, Curt Manufacturing LLC., may repair or replace the product, at their option, when the product is returned, prepaid, with proof of purchase. Alteration to, misuse of, or improper installation of this product voids the warranty. Curt Manufacturing LLC.'s liability is limited to repair or replacement of products found to be defective, and specifically excludes liability for incidental or consequential loss or damage.