

16465 TOYOTA TUNDRA (STANDARD CAB LONG BOX)

DO NOT EXCEED VEHICLE MANUFACTURER'S RECOMMENDED TOWING CAPACITY.

Parts List			
ITEM	QTY	PART NUMBER	DESCRIPTION
1	1	CM16465-DS	.250" DRIVER SIDE PLATE
2	1	CM16465-PS	.250" PASSENGER SIDE PLATE
3	4	5_8 - 11 x 2 HEX	HEX BOLT
4	4	5/8-11	HEX FLANGE NUT
5	4	5/8"	WASHER WIDE
6	4	CM-SP132	.25 x 2.50 SPACER
7	10	CM-SP136	.313" x 1.00 x 2.00" U-SHAPE SPACER
8	10	1/2 - 13 x 2"	CARRIAGE BOLT
9	10	HFN 1213	HEX FLANGE NUT
10	10	CM-SP33	.250 x 1.50 x 2.00" SQUARE HOLE SPACER

DRILL APPLICATION : NO
APPROX. INSTALL TIME: 60 MIN.
OTHER NOTES:

RAISE REAR BODY OF TRUCK

FRONT OF TRUCK

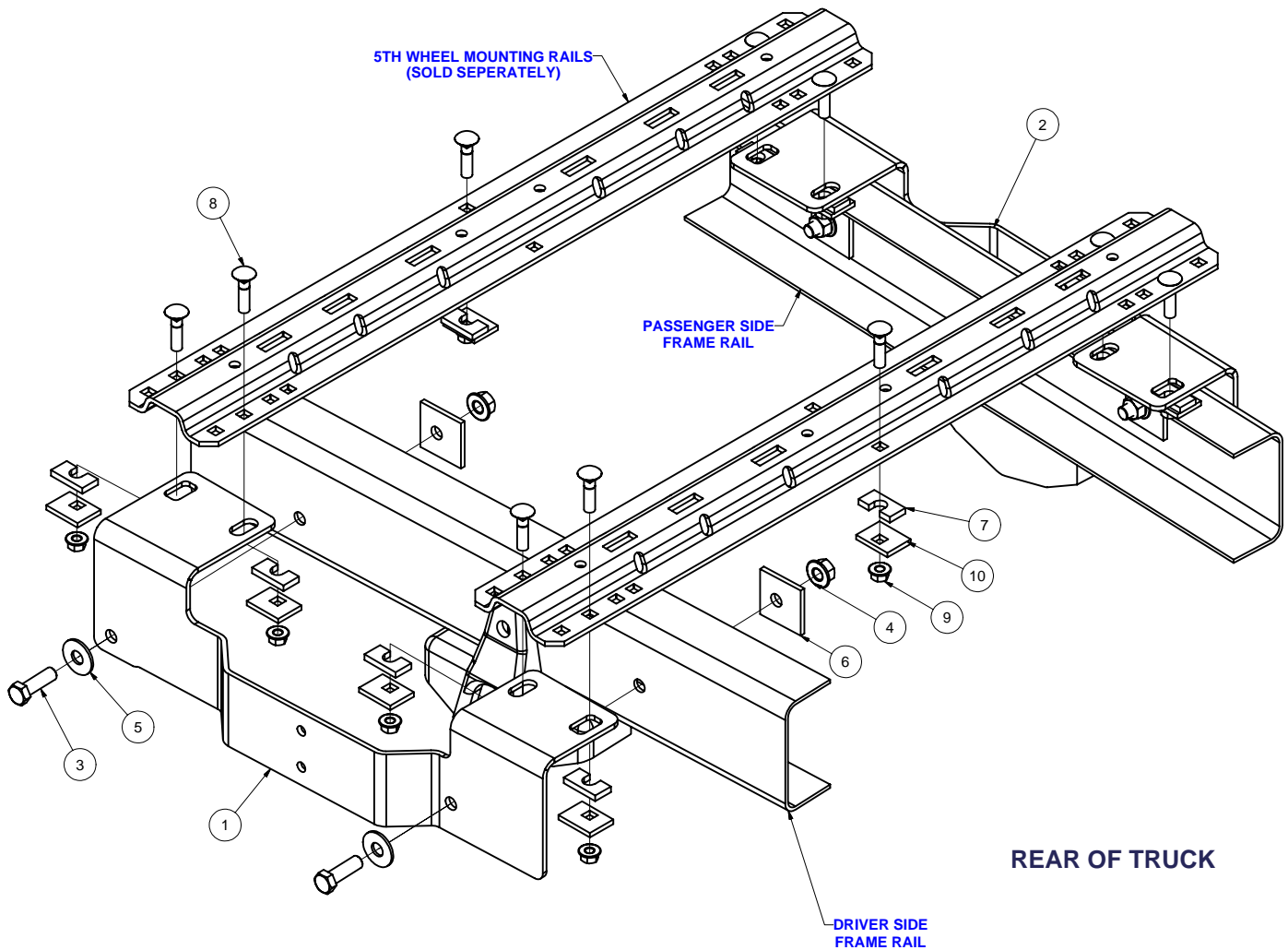

REAR OF TRUCK

RAIL LOCATION DIAGRAM

!!IMPORTANT!
 SYSTEM MAY NOT WORK WITH
 2003 AND EARLIER COMPETITOR
 PRODUCTS

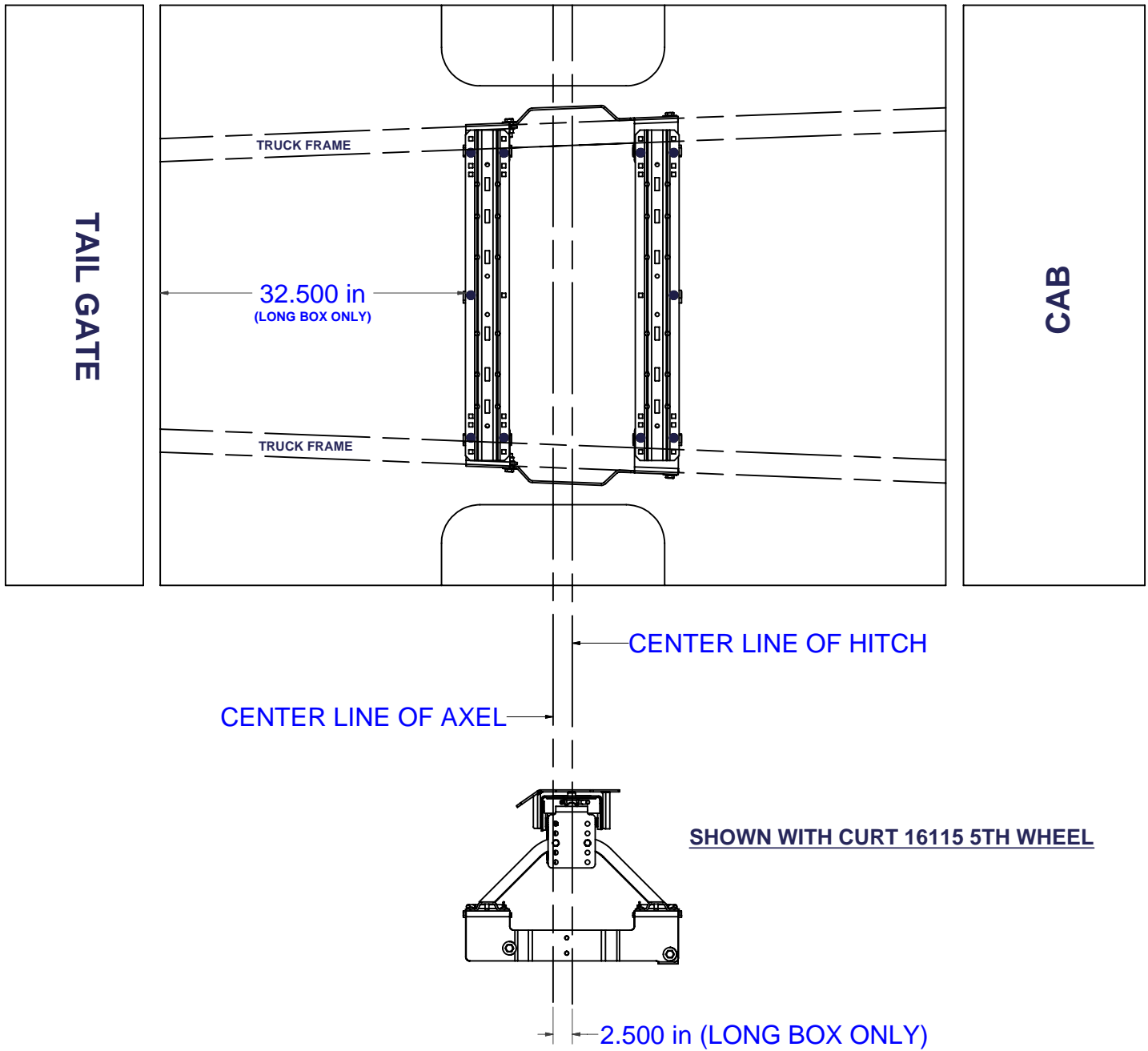



16465 TOYOTA TUNDRA (STANDARD CAB LONG BOX)

!WARNING!

- Do not install mounting rails over plastic bed liners. Plastic liners must be trimmed for metal-to-metal contact. May be installed on spray in liner.
- Use only supplied fasteners for installation.
- Before installing hitch measure to be sure there will be enough clearance between the truck and trailer to allow for turns.
- Frame rail must be clear of any electrical or brake components where side plates attach.

- 1) Raise rear of truck high enough to allow jack stands to be placed under the rear spring hanger bracket of the truck. This will provide maximum room to install the 5th wheel brackets.
- 2) Place one mounting rail in the box of the truck, using your tape measure, center the rail on the truck box floor and the proper distance from the rear edge of the truck box as shown on the "rail location diagram" page.
- 3) Using a center punch, mark the holes as per the rail location diagram. Move the mounting rail out of the way and drill each position with a 1/8" drill bit.
- 4) Temporarily position the side plate on the side of the frame and check that the 1/8" drilled holes align with the slots of the side plate. Remove the side plate from the vehicle.
- 5) Enlarge the 1/8" drill holes to the 9/16" with a step drill.
- 6) Fasten the side plate to the side of the frame using the appropriate hardware. Tighten hand tight.
- 7) Reposition the mounting rail over the holes and fasten the mounting rail to the side plates using the supplied carriage bolts. Use the supplied spacers between the frame bracket or mounting rails and the truck box so as to ensure a metal to metal contact and to eliminate "rib crush" of the bed.
- 8) Place the unassembled 5th wheel / roller / gooseneck hitch into the already installed mounting rail. Position the second mounting rail with the 5th wheel / roller / gooseneck hitch by inserting the tabs into the mounting rail and pushing the mounting rail tight towards the other mounting rail. Ensure that the mounting rail is centered on the truck box floor. This will position the rail in the correct location and ensure that the 5th wheel will have a snug fit to the truck.

NOTE: If more than one hitch product will be used with the mounting rails then both should be used at the same time to align the second mounting rail. This will ensure that one product does not compromise the fit of the other.

- 9) Repeat steps 3, 5, 6
- 10) Starting with the carriage bolts that fasten the rails to the frame bracket, torque all the nuts. Torque all 1/2" fasteners to 75 lb-ft and all 5/8" fasteners to 150 lb-ft.