



# CURT™

The FIRST Name  
in Towing Products™

# Q20 5TH WHEEL

## INSTRUCTION MANUAL



Installer: read and understand this manual. Fully instruct and demonstrate the operation of this 5th wheel hitch to the end user. Include the importance of observing all warnings contained herein, including warning labels on 5th wheel hitch mid section. Provide this manual in its entirety to the end-user.

*WARNING: to avoid serious injury, do not expose hands, body parts, or clothing between the truck and trailer or the truck's bed sides and trailer. Extreme care should be observed to avoid serious injury to self, property, and observers.*

**Never Position yourself or others under the trailer's kingpin area during coupling and uncoupling. Serious injury or death may result if the warning above is not observed.**

# TABLE OF CONTENTS

Warning Statements	Page 2
<b>Assembly and Installation</b>	<b>Page 3 - 4</b>
Unpacking	Page 3
<b>Coupling and Locking</b>	<b>Page 5 - 7</b>
Coupling	Page 7
Pull test	Page 7
<b>Uncoupling and Resetting</b>	<b>Page 8</b>
<b>Removal and Reinstallation</b>	<b>Page 9 - 10</b>
<b>Maintenance Requirements</b>	<b>Page 11 - 12</b>
Warranty	Page 12

## ⚠ WARNING STATEMENTS ⚠

- **Never exceed the rated towing capacity of your vehicle.** Trailer and contents combined must not exceed tow vehicle, hitch, and or trailer tow ratings. Exceeding rated capacity may result in separation. Exceeding rated capacity may result in damage to 5th Wheel Hitch, towing vehicle, trailer, and or cause serious injury or death.
- **Do not expose hands, body parts, or clothing between the truck and trailer or the truck's bed sides and trailer (DANGER ZONES).** Extreme care should be observed to avoid serious injury to self, property, and observers.
- **Never position yourself or others under the trailer's kingpin area (DANGER ZONE) during coupling and uncoupling.** If for any reason, you must position any part of your body under the trailer or between the truck and trailer or between the trailer kingpin and 5th Wheel Hitch you **MUST FOLLOW THE STEPS IN THE "DANGER ZONE PRECAUTIONS" SECTION BELOW.**
- Improperly coupled trailers can separate and drop without notice.
- Read and understand instructions before using this product.
- Observe all warnings contained in this manual and all warning labels on the 5th Wheel Hitch.
- **Serious injury or death may result if the warnings above are not observed.**

## DANGER ZONE PRECAUTIONS

- 1.) Block all trailer tires in front and behind with appropriate wheel chocks. Do not substitute objects such as, but not limited to: stones, wood blocks, etc.
- 2.) Front trailer lifting jacks must be supporting the trailer and resting on a firm and level surface.
- 3.) Towing vehicle must be stationary with automatic transmission in park, emergency brake applied, and engine off. If equipped with a manual transmission place in neutral, apply emergency brake, and shut off the engine.

# ASSEMBLY AND INSTALLATION

**Your Q20 5th Wheel has been partially assembled, inspected and tested for fit, function and completeness. The Q20 5th Wheel is an engineered unit that has been designed and tested at the rating of 20,000 lbs. (trailer GVW).**

## UNPACKING

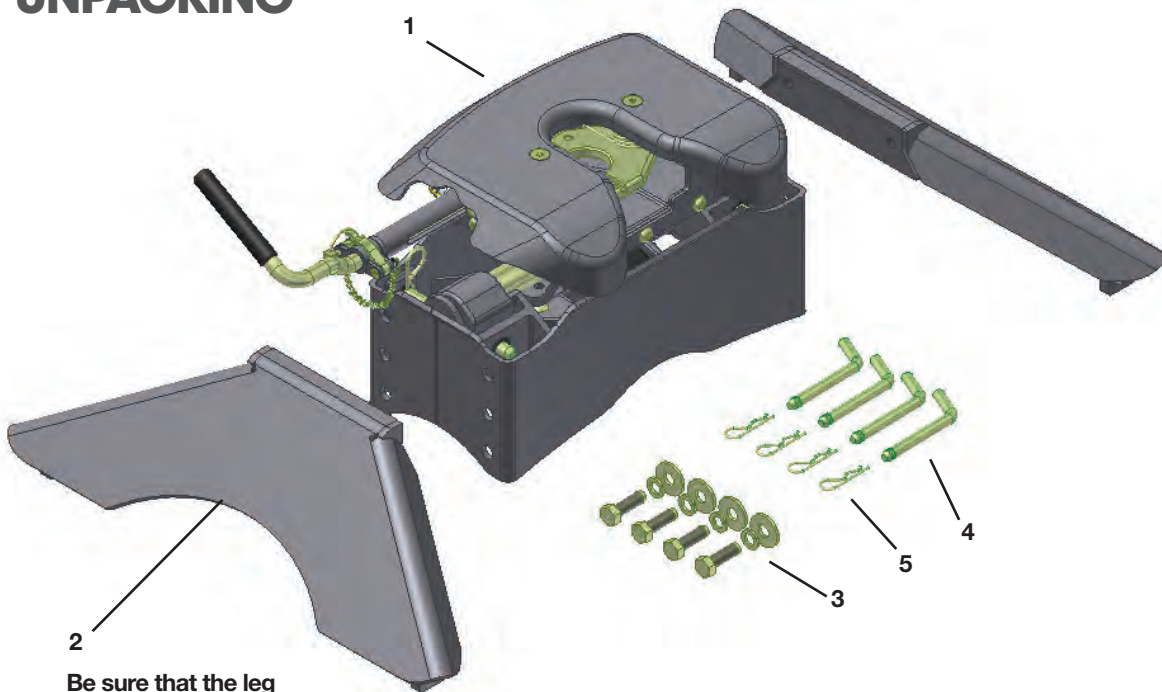

**2**  
Be sure that the leg with the Warning and Instruction labels is placed on the side of the unit with the activation bar.

The Q20 5th Wheel is packed in a reusable box. Contents will include:

1. (1) The Q20 5th Wheel Head assembled to the Mid-Section
2. (2) Legs (16130 only)
3. (4) M14, 2 x 45 mm Pilot Hex Bolts
4. (4) 14 mm Flat Washers
5. (4) 14 mm Lock Washers
6. (4) 1/2" diameter Base Rail Mounting Pins
7. (4) Base Rail Mounting Pin Hairpin Clips

# CALCULATING THE ASSEMBLY HEIGHT

Assembly includes measuring the height requirement for the Q20 5th Wheel Head in relation to your trailer ride height at the kingpin box and skid plate. Ideally the trailer should ride as near to level as possible. The Q20 5th Wheel is adjustable from 13 to 17 inches from the pickup bed to the top of its Skid Plate. Adjustment is attained by adjusting the Mid-Section up or down in relation to the legs in 2 inch increments (typical clearance between the pickup bed rails and the trailer should be a minimum of 5-1/2 inches.)

- Step 1. With your trailer on a firm and level surface, set chock blocks in front of and behind the tires. (Do not substitute wood blocks, rocks, etc. for chock blocks.) Extend front trailer lifting jacks, adjust as required to set trailer at or near level.)
- Step 2. Measure from the ground to under the trailer's kingpin box skid plate (or Lube Plate if used). This will be the portion in contact with the Q20 5th Wheel's Skid Plate once coupled.
- Step 3. Measure from the ground to the surface of the pickup bed.
- Step 4. Subtract the measurement from Step 2 from Step 1. This value will be near the height requirement for the Q20 5th Wheel.

## ASSEMBLY

Once you have determined the height adjustment required for your Q20 5th Wheel, assemble the legs to the Mid-Section using the appropriate holes. Occasionally, the trailer's kingpin "pin box" will require adjustment to facilitate correct ride height.

**Very Important! Torque the four pilot bolts to 100 ft-lbs. Retorque after initial 500 miles and every 1,000 miles thereafter and prior to each individual use.**

- Step 1. Depending on which holes are selected, attachment of the Legs to the Mid-Section may be easier with the Mid-Section upside-down sitting on its Skid Plate.
- Step 2. The Head Assembly can be removed from the Mid-Section to further aid in the installation of the pilot bolts.
- Step 3. If the Q20 5th Wheel is being mounted to existing Bed Mounting Rails, and alignment issues arise, it may be necessary to proceed as follows:
  - a. Loosely assemble the Legs to the Q20 5th Wheel Mid-Section. Place the unit on top of the existing Bed Mounting Rails aligning the Foot Tabs with the outermost rectangular slots of the Mounting Rails. When the 5th Wheel Foot Tabs drop into the 4 rectangular slots, pin the Foot Tabs using the (4) Pins and Clips provided. Continue assembly by tightening the Pilot Hex Bolts to 100 ft-lb.
  - b. If difficulty is still experienced fitting the Q20 5th Wheel to the existing Bed Mounting Rails, it may be necessary to loosen the Mounting Rail Bolts and realign the Mounting Rails as required to facilitate installation. It is recommended to replace old Lock Washers with new Lock Washers at this time. Torque Mounting Rail Bolts to (75 ft-lbs). Continue with the Q20 installation by tightening the Pilot Bolts to 100 ft-lb.
  - c. If using new Bed Mounting Rails follow the Mounting Rail's instructions for proper placement, alignment, and spacing.

# COUPLING AND LOCKING

## CAB VIEW

### Indicator Positions Showing Coupled and Locked 5th Wheel

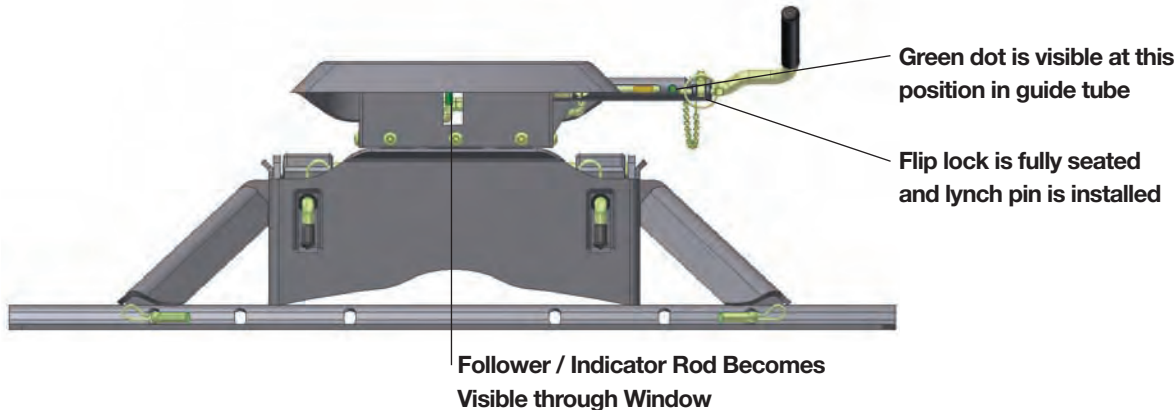

## PREPARING VEHICLE/ TRAILER TO COUPLE

1. It is advised to perform trailer connections to the 5th Wheel on a firm and level surface.
2. Multiple wheel chocks should be used in front of and behind trailer tires. Do NOT substitute objects such as, but not limited to: stones, wood blocks, etc.
3. Lower or remove truck tailgate as required.
4. Position towing vehicle with 5th Wheel centered and inline with trailer or coach kingpin. Do NOT engage kingpin into 5th Wheel at this time.
5. Set automatic transmissions to park and activate emergency brake. Set manual transmissions to neutral and activate emergency brake.
6. Rear stabilizer jacks must be retracted. Adjust the front trailer lifting jacks so the trailer's kingpin skid plate is approximately 1/2 inch below the top surface of 5th Wheel Skid Plate. Hooking up in this manner helps ensure proper engagement of the trailer kingpin to most 5th Wheel systems. NEVER LOWER THE TRAILER'S KINGPIN INTO THE 5TH WHEEL HITCH HEAD.

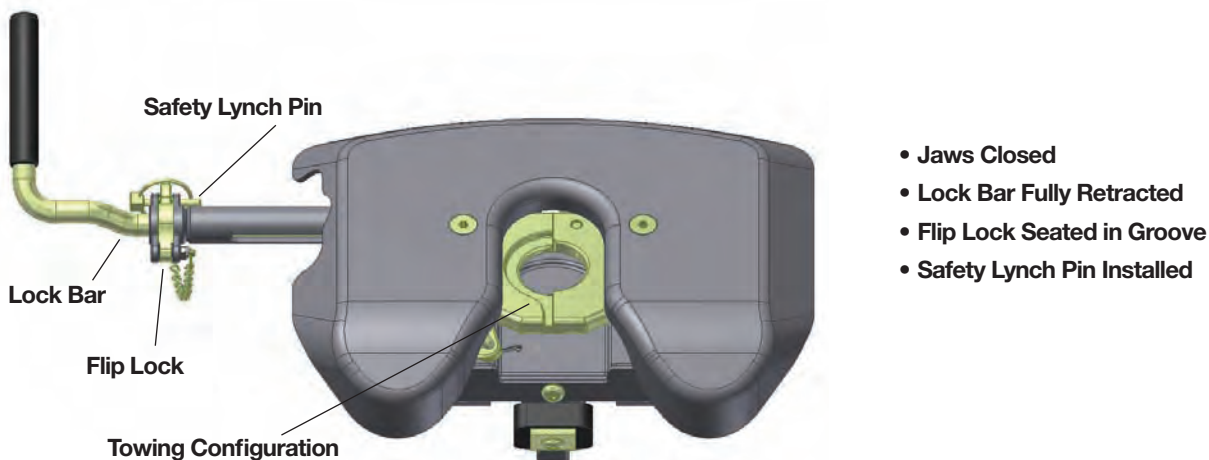

# PREPARING 5TH WHEEL TO COUPLE

Refer to “Cab View” on the top of page 5 and the coupling diagram on the bottom of page 5.

1. Note that Green Dot is visible (cab side) through Lock Bar Guide Tube and Indicator Rod is visible through window.
2. Flip Safety Lynch Pin Bail and remove Lynch Pin.
3. Lift Flip Lock, rotate clockwise and let hang.
4. Pull Lock Bar to full extension (approximately 3-1/2 inches) until Jaws activate and open, then release Lock Bar.
5. Visually check that Jaws are open and ready to receive trailer kingpin.
6. Note that Green Dot, and Indicator Rod have moved. This signifies that 5th Wheel Jaws are NOT in their closed and locked position. The Yellow Dot should now be visible. Yellow signifies the 5th Wheel is ready for coupling.
7. If the 5th Wheel is in any configuration other than that described in Step 1, follow the preparation troubleshooting guide below

## PREPARATION TROUBLESHOOTING

### Red Dot

**WARNING: DO NOT TOW IN THIS CONFIGURATION! JAWS WILL CLOSE BUT WILL NOT LOCK. FOLLOW STEPS BELOW TO PREPARE FOR COUPLING**

Jaws Open but Lock Bar is at extended position and being held by Flip Lock / Red Dot is visible (cab side) through Lock Bar Guide Tube.

1. Red Dot signifies that Jaws are open and that Lock Bar is in its extended position. Jaws will close, but will **NOT** lock in this configuration.
2. Lightly pull Lock Bar and release Flip Lock from its groove.
3. Release Lock Bar. Lock Bar will retract partially inward.
4. Visually check that Jaws are open and ready to receive trailer kingpin. The Yellow Dot should be visible from cab.

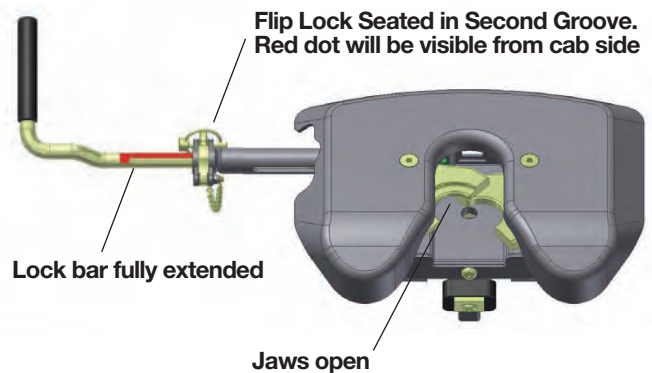

### Out of Sync Jaws

Jaws are semi-open and interlocked/interlaced with each other. Lock Bar is somewhere in between full retracted position and full extended position.

1. This configuration means that the Movable Jaw has become out of time with the second Fixed Jaw.
2. Inspect that Flip Lock is hanging free in its clockwise rotated position.
3. Pull Lock Bar to its full extended position and release.
4. Jaws will retune themselves.
5. Visually check that Jaws are open and ready to receive trailer kingpin (Yellow Dot).

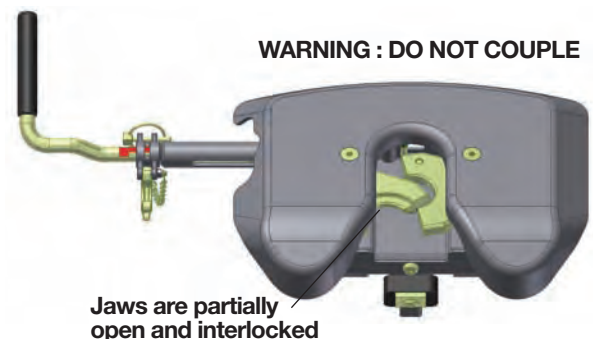

# COUPLING

If you are using a Lube Plate on the trailer kingpin, you are ready to couple the trailer to the 5th Wheel. (Up to (2) 3/16" thickness Lube Plates may be used). If you are not using a Lube Plate, apply a high pressure wheel bearing grease to the 5th Wheel Skid Plate.

**Never position yourself or others under the trailer's kingpin area (DANGER ZONE) during coupling and uncoupling.**

If for any reason, you must position any part of your body under the trailer or between the truck and trailer or between the trailer kingpin and 5th Wheel Hitch you **MUST FOLLOW THE STEPS IN THE "DANGER ZONE PRECAUTIONS" ON PAGE 2.**

Back towing vehicle while remaining centered and aligned to trailer kingpin. Trailer kingpin skid plate will compress the towing vehicle's suspension and "ramp" up onto 5th Wheel Skid Plate. Observe the following: See "cab view" on Page 5 for indicator location.

- a. Lock Bar will fully retract into 5th Wheel Head.
- b. Green Dot will become visible (viewing from cab).
- c. Green Indicator Rod is visible in window (viewing from cab).

Visually confirm that no space exists between trailer kingpin skid plate and 5th Wheel Skid Plate or between Lube Plate and 5th Wheel Skid Plate. If a gap is present then kingpin is NOT engaged into Jaws.

Step 1. Determine if kingpin is resting on top of Jaws and provide corrective action.

Step 2. Inspect for damage to 5th Wheel Unit. Under no circumstances should 5th Wheel Unit be used if damage exists due to improper coupling.

Step 3. If no damage exists, review coupling instructions and repeat procedure.

# PULL TEST

After coupling and prior to removing trailer wheel blocks and or raising front trailer jacks **YOU MUST DO THE FOLLOWING:**

Set towing vehicle in a forward gear and lightly "tug" on the trailer to **ensure that a 100% coupling has taken place.** If resistance is felt, release forward pressure, set vehicle to Park if equipped with an automatic transmission and activate emergency brake. Place in Neutral if equipped with a standard transmission and activate emergency brake.

**If resistance is not felt,** trailer may not be coupled correctly. Do not continue applying forward pressure, **immediately stop,** and back towing vehicle into original position. Do not allow the truck and trailer to separate. Separation can cause damage to towing vehicle, 5th Wheel Hitch, and or trailer. **Serious injury or death may result if all warnings are not observed.**

Review coupling instructions, apply corrective action and repeat coupling steps.

# PREPARING TO TOW

1. Rotate Flip Lock counterclockwise and seat in groove.
2. Insert Safety Lynch Pin and flip bail to secure.
3. Attach electrical harnesses.
4. Attach lanyard and insert electric-brake-break-away plunger. If hydraulic surge brakes are present, attach lanyard from the surge brake assembly as required.
5. Fully retract front trailer lifting jacks.
6. Close truck tailgate or reinstall tailgate as required.
7. Remove tire chock blocks.
8. Check running lights, directional signals, and brake lights for proper operation.
9. Pull forward a few feet and apply brakes to check that trailer brakes are activating. Adjust the electric brake controller if necessary.

# UNCOUPLING AND RESETTING

1. When parking it may be necessary to “unload” the forces on the kingpin by lightly backing “against” the kingpin. This maneuver helps put the kingpin and 5th Wheel in a “neutral” position. Once parked on a firm and level surface, set automatic transmission vehicles to Park and activate emergency brake, set standard transmission vehicles to Neutral and activate emergency brake.
2. Multiple wheel chocks should be used in front of and behind trailer tires. Do NOT substitute objects such as, but not limited to: stones, wood blocks, etc.
3. Disconnect as required, all harnesses, lanyards, safety devices, etc.
4. Do NOT extend rear trailer stabilizer jacks at this time.
5. Lower or remove truck tailgate as required.
6. Begin extending front trailer lifting jacks. Extend lifting jacks just enough to remove the weight of the trailer from the 5th Wheel Skid Plate. Creating a “gap” between the trailer skid plate and the 5th Wheel Skid Plate is NOT necessary and is NOT recommended. If a gap is present, it should be minimal and no more than 1/16 of an inch. Excessive gap while coupled can damage internal components of the 5th Wheel Hitch as well as components of your trailer.
7. Flip Safety Lynch Pin Bail and remove Lynch Pin.
8. Lift Flip Lock and pull Lock Bar outward approximately 1/2 inch. While holding Lock Bar in this position, drop Flip Lock back onto the lock bar. Pull Lock Bar to its full extension. Flip Lock will drop and engage second groove. Release Lock Bar. Lock Bar should remain in full extended position. Note that Red Dot is visible (cab side) through Lock Bar Guide Tube. This signifies that the jaws are NOT locked and are prepared to be uncoupled.
9. Reinsert Safety Lynch Pin and flip bail to secure.
10. Slowly pull vehicle out from underneath trailer skid plate. Observe that trailer is uncoupling. If resistance is encountered, determine corrective action and repeat uncoupling steps.
11. Once uncoupled from trailer, you may elect to reset 5th Wheel for future coupling at this time. To reset for future coupling, simply remove the Safety Lynch Pin and lift the Flip Lock from its groove. This will allow the Lock Bar to partially retract into its coupling position.

Important: Failure to reset Lock Bar in this manner prior to next coupling will NOT allow the jaws to lock around the trailer’s kingpin. See diagram below.

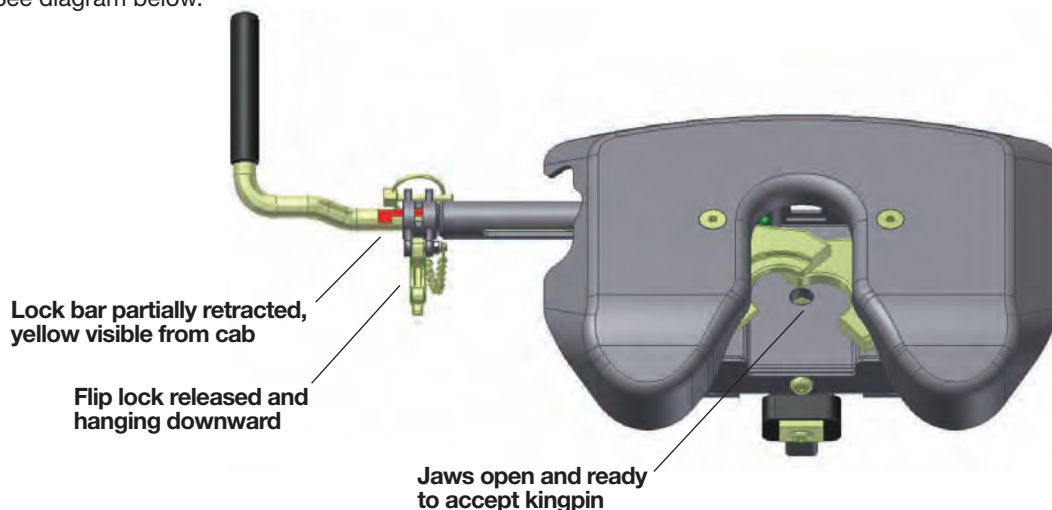

# REMOVAL AND REINSTALLATION

For your convenience the Q20 5th Wheel Hitch may be disassembled to ease removal. This section will discuss the three different way the Q20 hitch can be removed.

## OPTION 1

**Recommended:** Separate head from mid-section and remove mid-section and sides as one unit

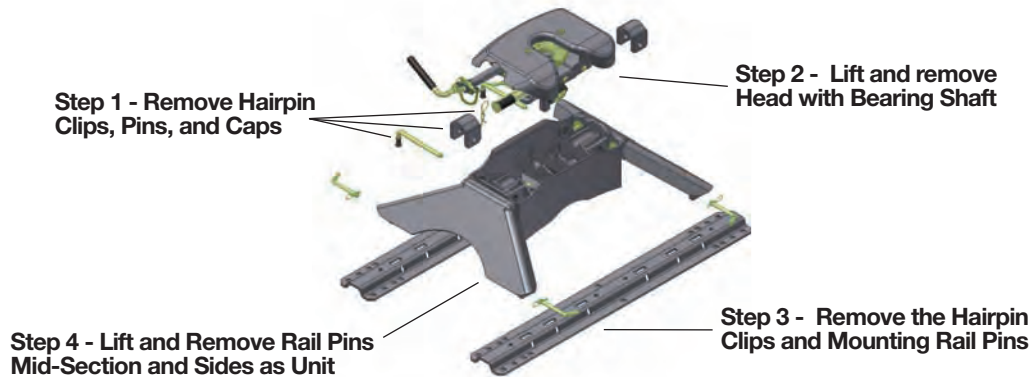

Note: it is helpful to reinstall the caps pins and clips

## OPTION 2

Separate head and legs from mid-section,

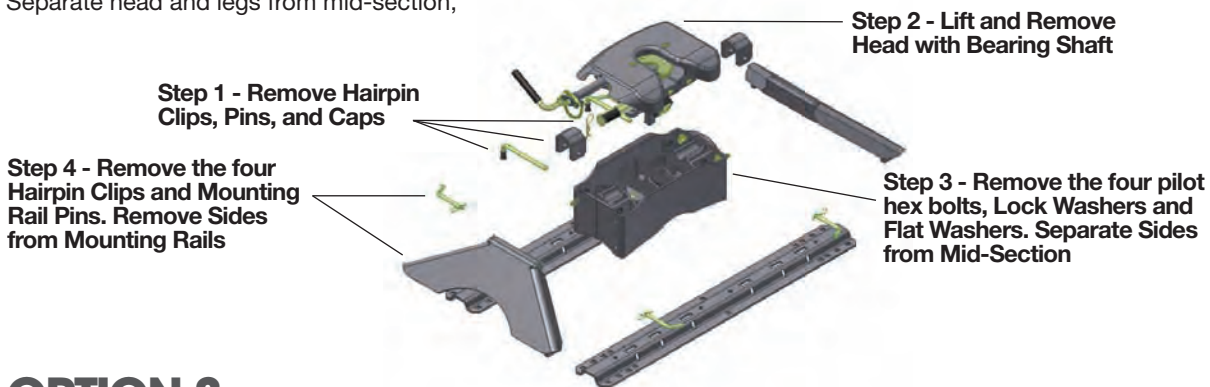

## OPTION 3

**Not recommended:** Separate entire 5th wheel hitch from base rails

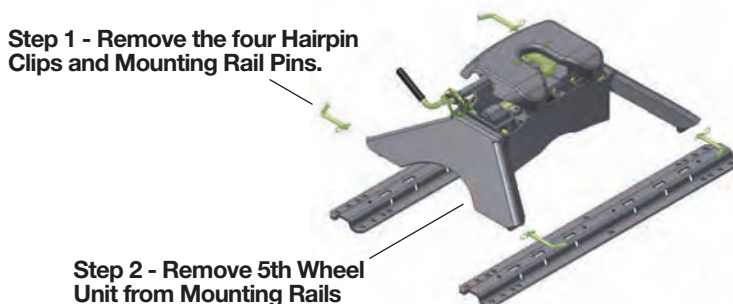

# REINSTALLATION

Reinstall the Q20 5th Wheel in the reverse order it was removed. If removal method was per **option 1**, please follow the steps below:

- a. Place the Mid-Section still securely bolted to the legs into the Mounting Rails
- b. Insert the (4) Mounting Rail Pins.
- c. Install the (4) Hairpin Clips.
- d. Retorque (4) Pilot Hex Bolts to 100 ft-lb.

**IMPORTANT:** When installing the 5th Wheel Head into the Mid-Section, the LONG END of the Bearing Shaft is inserted into the Lower Bearing Assembly. The Machined Bearing Retainer must be against the Lower Bearing Assembly. The Removable Bearing Retainer must be against the other side of the Lower Bearing Assembly. The O-Ring Retainer Stop is placed in its groove lastly.

Apply a light film of lubricant to the Lower Pilot. Guide Lower Pilot into Mid-Section while holding Bearing Shaft and its Retainers against Lower Bearing Assembly. Continue to guide Lower Pilot through the Lower Square Pad until the Bearing Shaft is fully seated in its Saddles. Place Shaft Caps over the Bearing Shaft. Install the two long Pins and insert two Hair Pin Clips. See diagrams below.

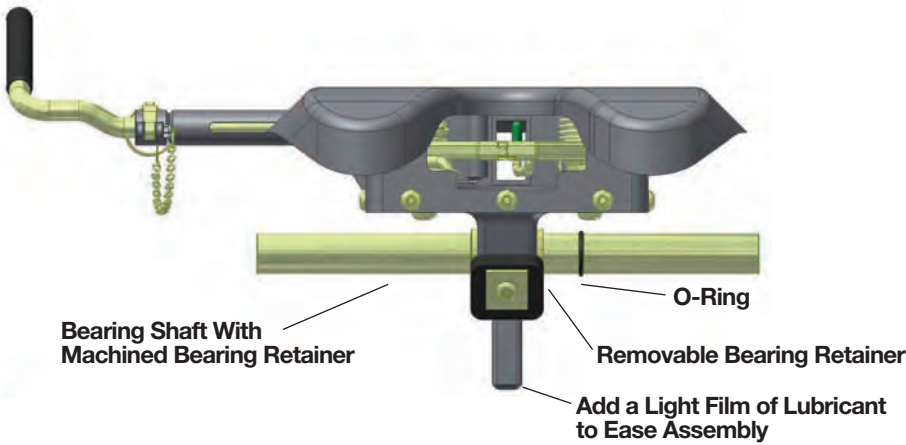

Ensure that the Machined Bearing Retainer and the Removable Bearing Retainer are against Lower Bearing Assembly. Both sit inboard of Mid-Section Bearing Shaft Cradles during assembly.

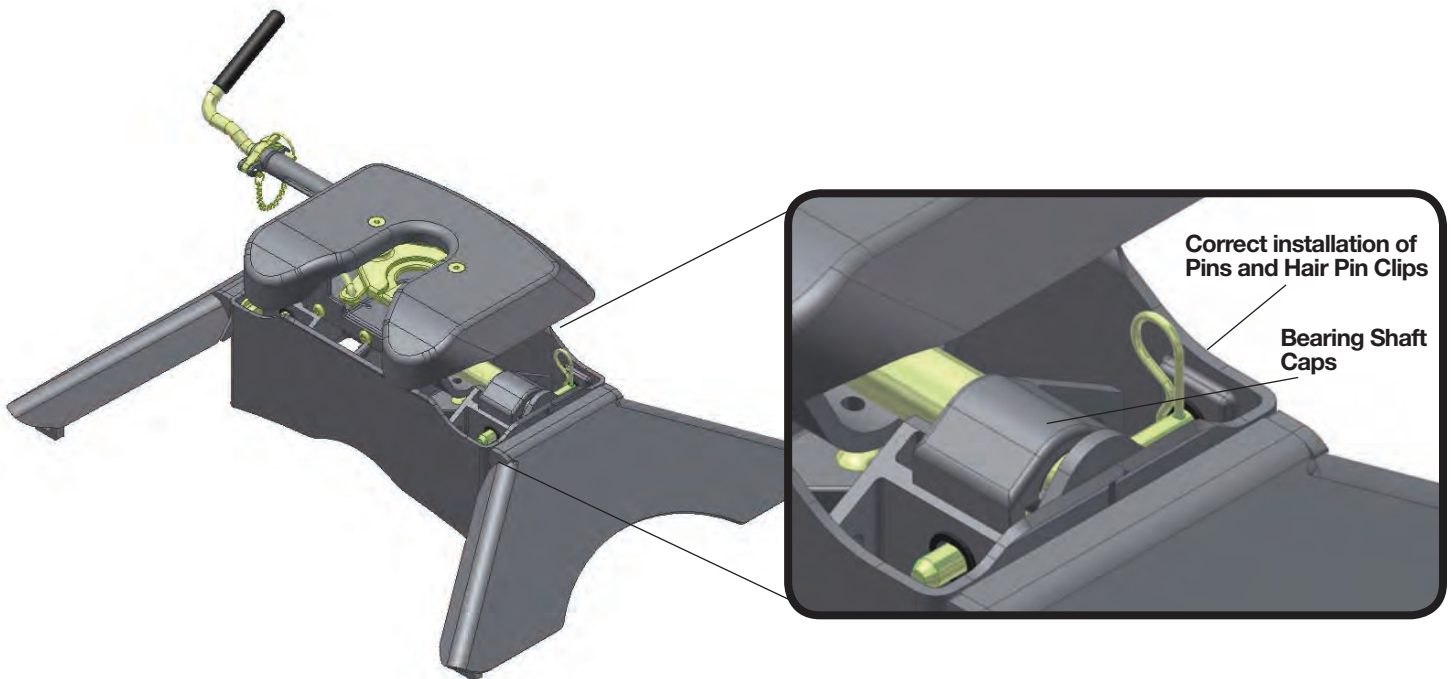
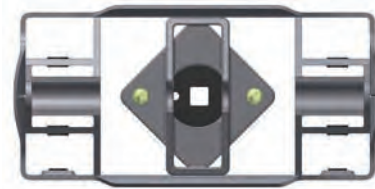

# MAINTENANCE REQUIREMENTS

Years of troublefree service may be achieved by adhering to a few simple maintenance points.

## JAW PIN GREASE FITTINGS

Each Jaw Pin is supplied with grease through a grease fitting located in each Jaw. These grease fittings are visible from each side of the Q20 5th Wheel.



## LOWER BEARING GREASE FITTING

The Lower Bearing Assembly is supplied with grease through the grease fitting centered in the Cast Base Plate. This grease fitting is visible while looking down through the Jaws in their LOCKED position.



## SPIRAL CAM GREASING

The Spiral Cam seated in the Cast Base Plate requires the application of grease into its pocket. To access, the Jaws must be open. Place the Lock Bar in its fully extended position and retain by seating the Flip Lock in its Uncoupling position. Insert the Safety Lynch Pin. Using a suitable probe, apply grease to the pocket under the Spiral Cam. When complete, remove the Safety Lynch Pin, rotate the Flip Lock from its seat and allow the Lock Bar to retract inward into the coupling position.

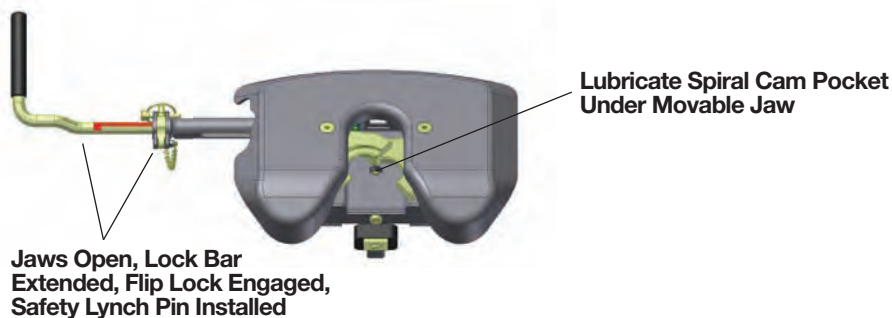

## SKID PLATE GREASING

The last lubrication point is the Q20's Skid Plate. Liberally apply Grease to the Skid Plate surface if NOT using a Lube Plate. A high-pressure wheel bearing grease is preferred. Apply as required between coupling and uncoupling the trailer from the Q20 5th Wheel.



Apply Grease to Skid Plate  
if NOT using Lube Plate

## MAINTENANCE SCHEDULE

Lubricate before each individual use and every 1000 miles thereafter. Black Graphite Grease is recommended for the Jaw Pins and the Lower Bearing Assembly Jaw. High pressure wheel bearing grease is preferred for the Skid Plate.

NOTE: In severe cold temperatures a lighter grease (such as White Lithium) may be substituted for the Jaw Pins and the Lower Bearing Assembly Jaw. This will ensure that all mechanisms work as designed.

**VERY IMPORTANT:** Torque the four Pilot Bolts to 100 ft-lbs. Retorque after initial 500 miles and every 1000 miles thereafter and prior to each individual use.

# CURT WARRANTY

## Ten Years Limited

CURT Manufacturing Incorporated ("CURT") warrants to the original purchaser ("Purchaser"), its products to be free from defect under normal use and service, ordinary wear and tear excepted, for the warranty period stated below, from the date of the original retail purchase, but subject to the limitations as set forth below.

### Limitation on Warranty

CURT's obligation under the above warranty is limited to repair or replacement of the CURT Product (Product), at its option due to a manufacturing defect of the Product. CURT shall not be liable for the loss of or use of vehicles, loss of or damage to personal property, expenses such as telephone, lodging, gasoline, towing, tire damage or any other incidental or consequential damages incurred by the Purchaser, or any other person or entity.

CURT will examine the returned Product. If CURT, in its exclusive discretion, determines that the defect or damaged Product is covered under this limited warranty, CURT will repair the Product or replace it at that time.

Alterations to or misuse of the Product will void the warranty. For example, overloading or exceeding an automobile or trailer manufacturers' weight ratings, or maneuvering motor vehicles equipped with Products at improper rate of speed, shall void the warranty on any of the Products. Failure to properly maintain and regularly inspect the Product according to the specific instruction sheet accompanying each Product shall also void the warranty.

Some states do not allow the exclusion or limitation of incidental or consequential damages. If such exclusions or limitations are prohibited under the applicable law, the above limitation or exclusion may not apply.

This Warranty gives you specific legal rights and you may also have other rights, which vary from state to state.

The Purchaser, when returning a CURT Product, must follow the following steps:

1. The Purchaser must have proof of purchase of any damaged Product and supply the same to the headquarters of CURT. The Purchaser must obtain from CURT (Toll free number is 1-877-CURTMFG) a Returned Goods Authorization (RGA) number in order to return any damaged Product to CURT for inspection and evaluation under this Limited Warranty.
2. The Purchaser must pay all handling charges and shipping costs to deliver Products to CURT and must send the damaged Product along with the RGA number and proof of purchase to CURT at 6208 Industrial Drive, Eau Claire, Wisconsin 54701.
3. Upon receipt of damaged Product, CURT will determine whether the damaged Product is covered under the Limited Warranty. If it is, CURT will repair or replace the Product. If the Product is replaced, the Product that is originally returned by the Purchaser shall become the exclusive property of CURT. If the returned Product is not covered under the Limited Warranty, CURT will notify the Purchaser before taking any further action with regard to repair or replacement, which would be at the Purchaser's cost.



# CURT™

The FIRST Name  
in Towing Products™

# R20 ROLLER

## INSTRUCTION MANUAL - 16550



Installer: read and understand this manual . Fully instruct and demonstrate the operation of this 5th wheel hitch to the end user. Include the importance of observing all warnings contained herein to include warning labels on 5th wheel hitch mid section. Provide this manual in its entirety to the end-user.

*WARNING: to avoid serious injury, do not expose hands, body parts, or clothing between the truck and trailer or the truck's bed sides and trailer. Extreme care should be observed to avoid serious injury to self, property, and observers.*

**Never Position yourself or others under the trailer's kingpin area during coupling and uncoupling. Serious injury or death may result if the warning above is not observed**

# 16550 R20 5th Wheel Roller Unpacking

## 1. Unpacking

The R20 5th Wheel Roller ships in two boxes as indicated below. Inspect all parts for damage and verify that all items listed are present.

### Box 1 Contains:

- (1) CM-16550-RA R20 Roller Assembly DS (Qty 1)
- (2) CM-16550-RA R20 Roller Assembly PS (Qty 1)
- (3) CM-16550-020 Lock Rod Weldment DS (Qty 1)
- (4) CM-16550-019 Lock Rod Weldment PS (Qty 1)
- (5) CM-16550-011 Outer Tube (Qty 1)
- (6) CM-16550-012 Compression Spring (Qty 1)
- (7) CM-16550-014 Handle (Qty 1)
- (8) CM-16550-015 Handle Grip (Qty 1)
- (9) CM-16550-021 Cross Member Weldment (Qty 1)
- (10) CM-16550-BK Bolt Kit (Qty 1)

### Box 2 Contains:

- (11) 16200 Mounting Rail Kit (Ordered Separately) (Qty 1)

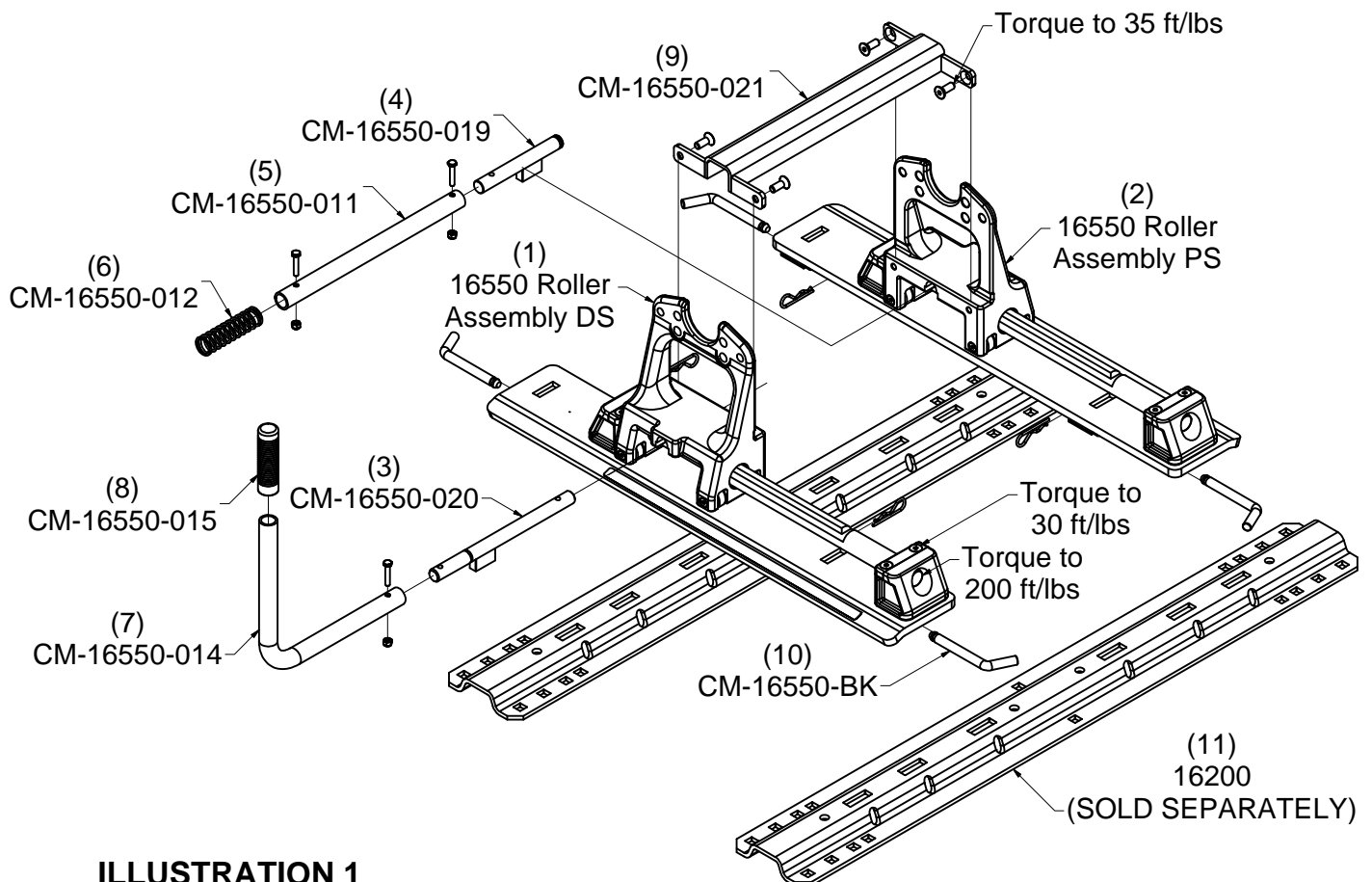
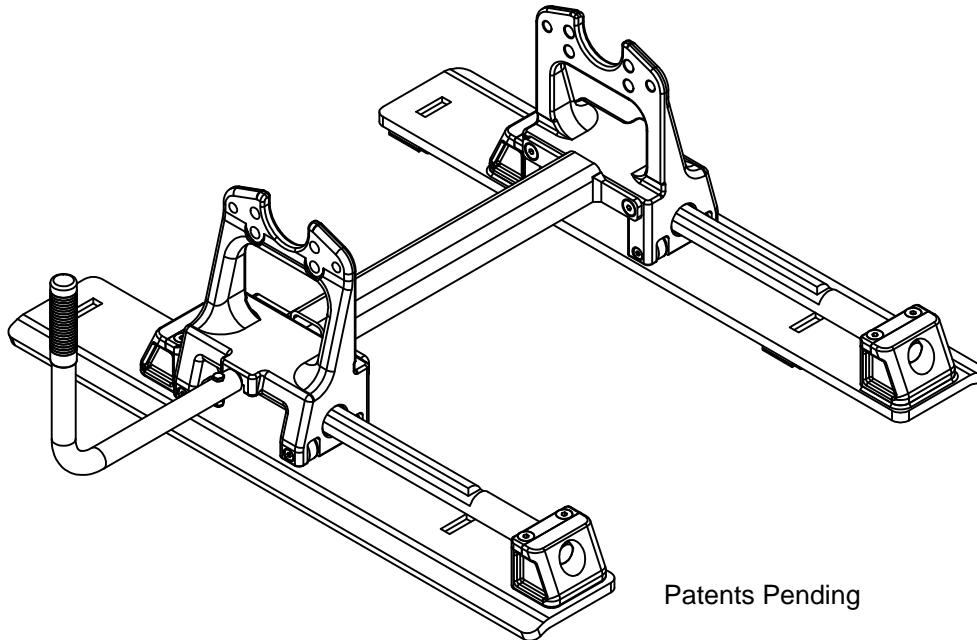

ILLUSTRATION 1

# 16550 R20 5th Wheel Roller Installation Instructions



Patents Pending

The **R20** roller is to be used with 5th wheel trailers which weigh up to 20,000 lbs. Never use on trailers exceeding 20,000 lbs.

**Caution:** The **R20** roller will reposition your 5th wheel hitch 12" rearward. HOWEVER this will **NOT** guarantee complete truck cab/trailer clearance when towing.

1. Before beginning assembly of the **R20** roller, check the base rails in your truck to be sure they are properly installed and are parallel with each other. The diagonal dimensions should be the same. See Illustration 2. With the base rails correctly positioned the assembled, the **R20** will drop into the slots on the top surface of the base rails.

**ILLUSTRATION 2**

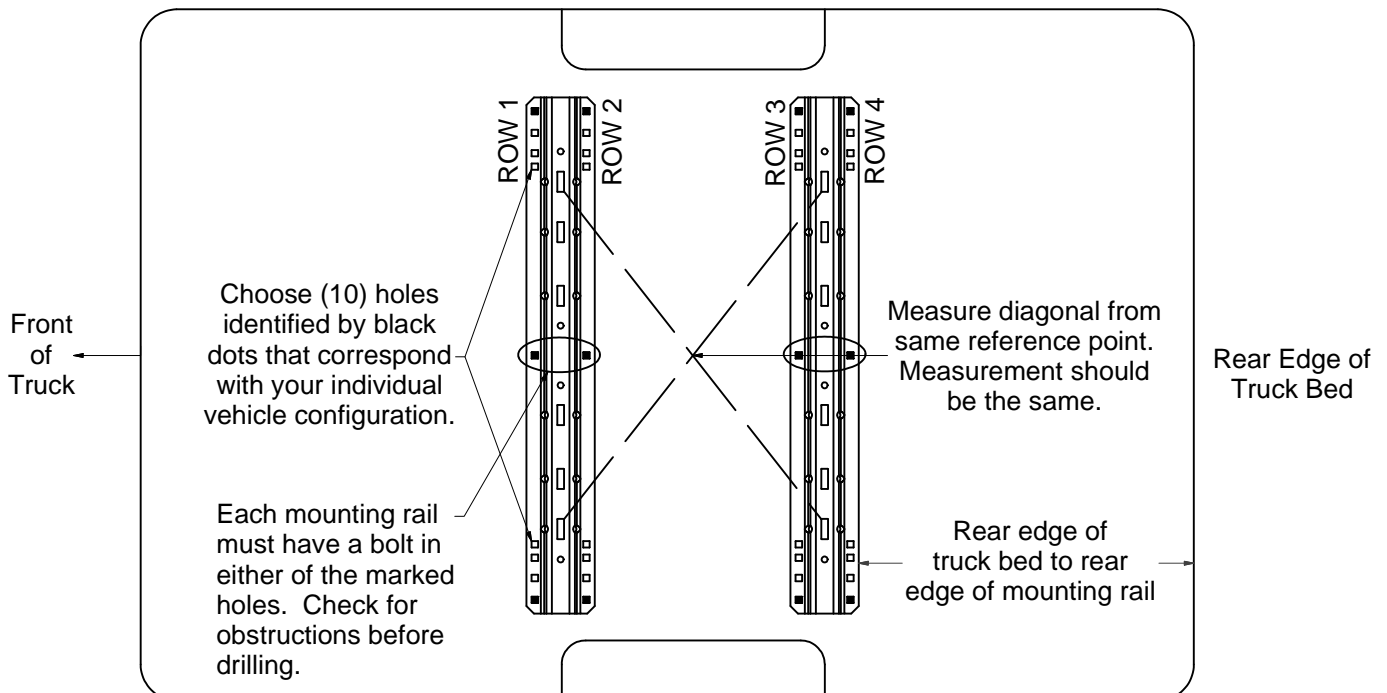

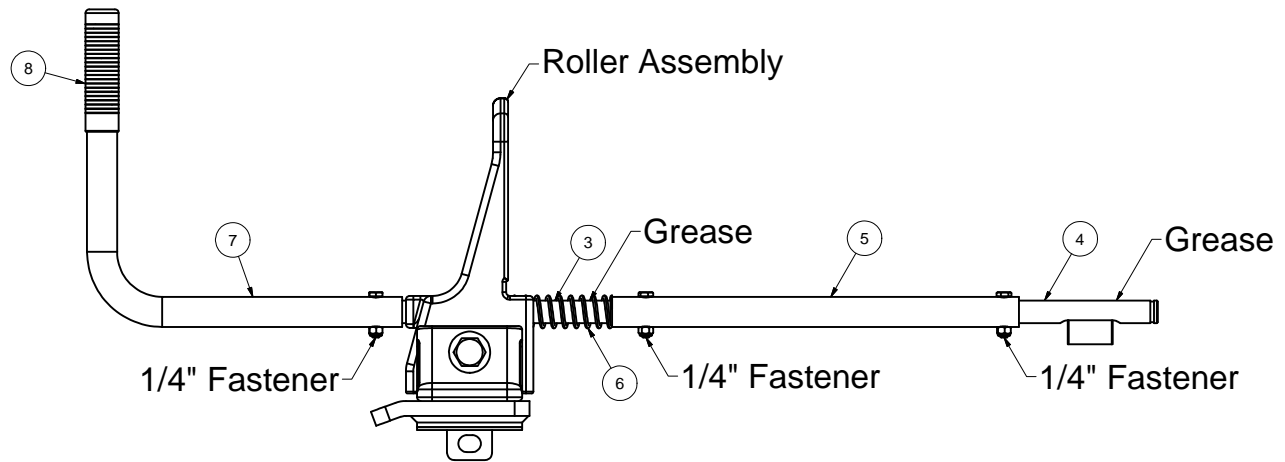
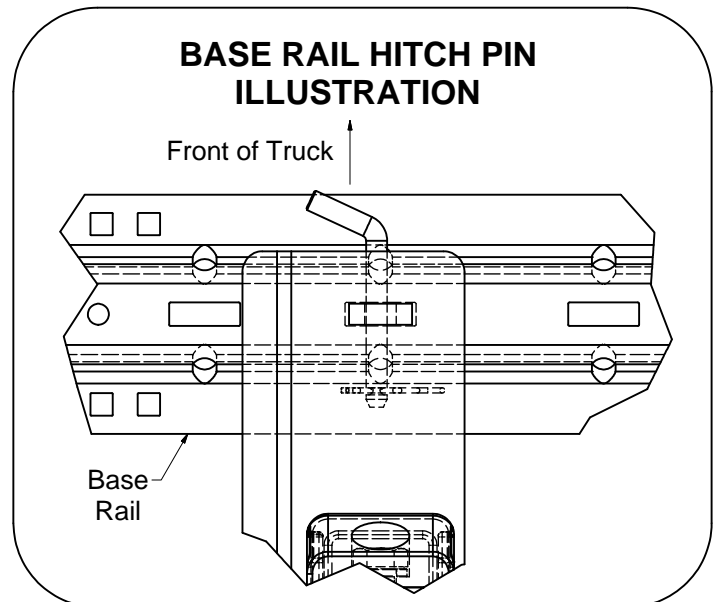

**ILLUSTRATION 3**

2. Grease the ends of the Lock Rod Weldments (3) and (4) as shown in Illustration 3.
3. Slide Lock Rod Weldment (3) into the DS Roller Assembly and slide Lock Rod Weldment (4) into the PS Roller Assembly.
4. Slide the Outer Tube (5) over Lock Rod Weldment (4) until holes line up. Secure with 1/4" fastener. Tighten until nylock nuts are fully engaged.
5. Slide Compression Spring (6) over Lock Rod Weldment (3).
6. Slide Lock Rod Weldment (3) with Compression Spring (6) into Outer Tube (5) until the holes line up. Secure with 1/4" fastener. Tighten until nylock nuts are fully engaged.
7. Slide Handle (7) over Lock Rod Weldment (3) until the holes line up. Secure with 1/4" fastener. Tighten until nylock nuts are fully engaged.
8. Slide Cross Member Weldment (9) between Roller Assembly DS (1), Roller Assembly PS (2) and over the Lock Rod assembly as shown in illustration 1. Secure with 3/8" flat head bolts and torque to 35 ft/lbs.
9. Place the assembled **R20** roller into the base rails and pin in place with the supplied hitch pins and clips.

**CAUTION**

Be sure that all base rail hitch pins are positioned as shown in the illustration to the right and that all hitch pin clips are secured before towing.



10. Pull handle out and rotate as shown on the operation decal on the roller. Roller should move smoothly fore and aft on the rails. **Note:** When the **R20** roller is locked in its fore and aft positions the lock bar handle should be vertical, the red indicator **WILL NOT** be showing and the green indicator **WILL** be showing. See illustration 4.
11. If unit binds, make sure all bolts are torqued to proper specifications. Make sure the base rails are square and parallel.

## ILLUSTRATION 4

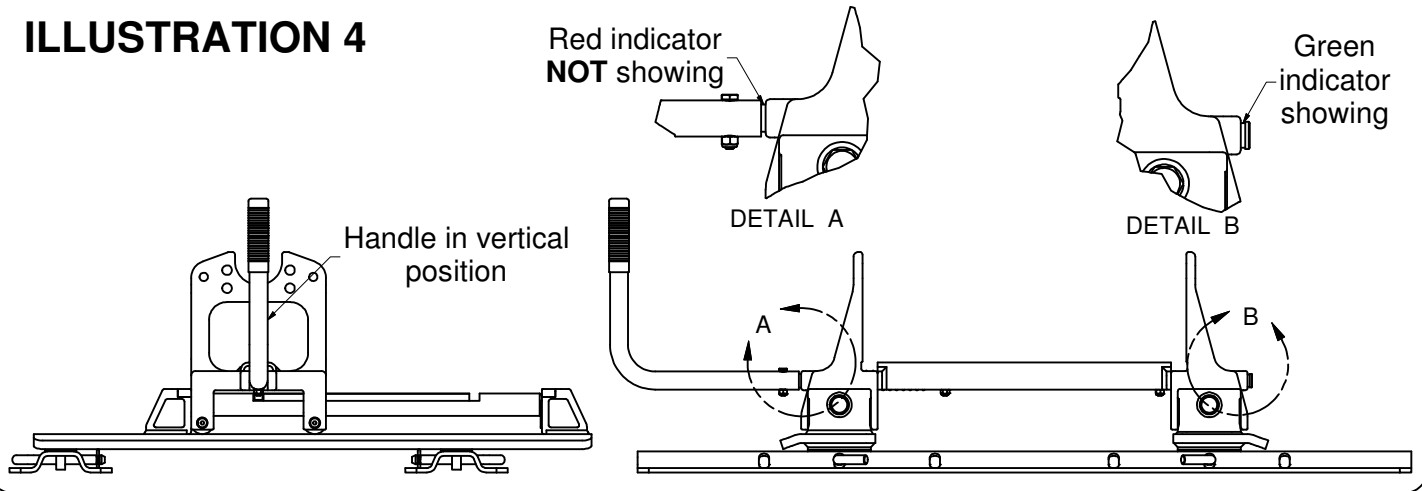

## Fifth Wheel Head Installation

To install the 16515 5th wheel head, slide the 16515 cross member weldment into the **R20** roller as shown. Select desired height using the adjustment holes in the cross member weldment. From the inside, insert four supplied 1/2" x 1 3/4" bolts into the four holes of the cross member weldment into the **R20** roller. Place 1/2" nylock nuts on each bolt. **Torque to 75 ft/lbs.** Place the 16515 5th wheel head into the cross member weldment saddle, insert supplied 3/8" hitch head pins and secure with hitch pin clips.

To install the 16530 5th wheel head, slide the 5th wheel head into the **R20** roller as shown. Select desired height using the adjustment holes in the mid section of the 5th wheel head. From inside, insert four supplied 14mm bolts into the four holes of the mid section into the **R20** roller. **Torque to 100 ft/lbs.**

Your **R20** is now ready for operation. See **OPERATION INSTRUCTIONS**.

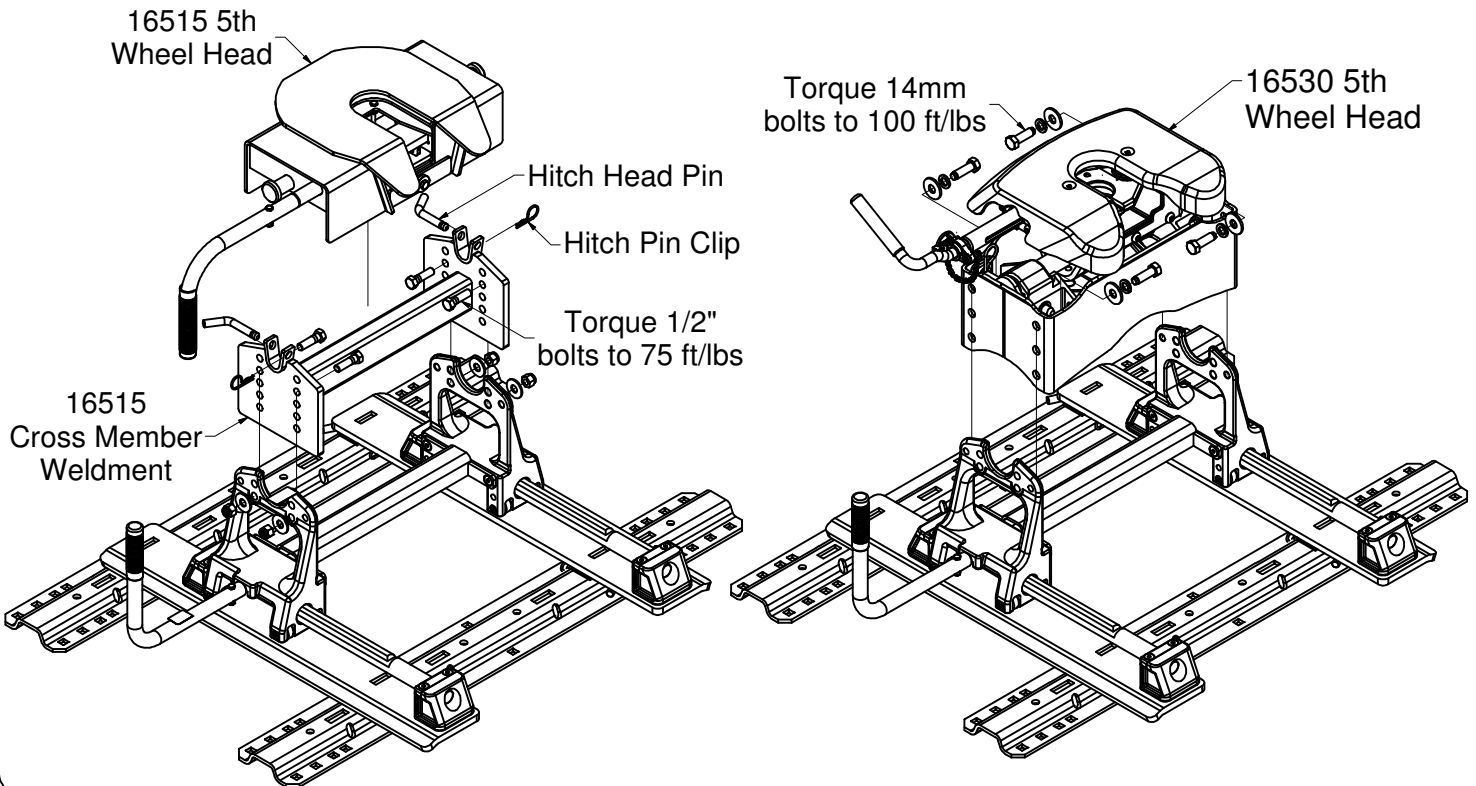

# OPERATION INSTRUCTIONS

## TO MANEUVER

1. Align trailer and tow vehicle in a straight line on a level surface.
2. Pull handle out and rotate counter clockwise to place lock bar in the ready to lock position.
3. Set trailer brakes and slowly drive the tow vehicle forward until **R20** roller stops. Locking bars will automatically engage in the Rear Locking Groove. **NOTE: Visually check that lock bar handle is vertical and both lock bars are fully engaged and that the green indicator is visible.**

### MANEUVER POSITION

Roller and Hitch will move 12" REARWARD

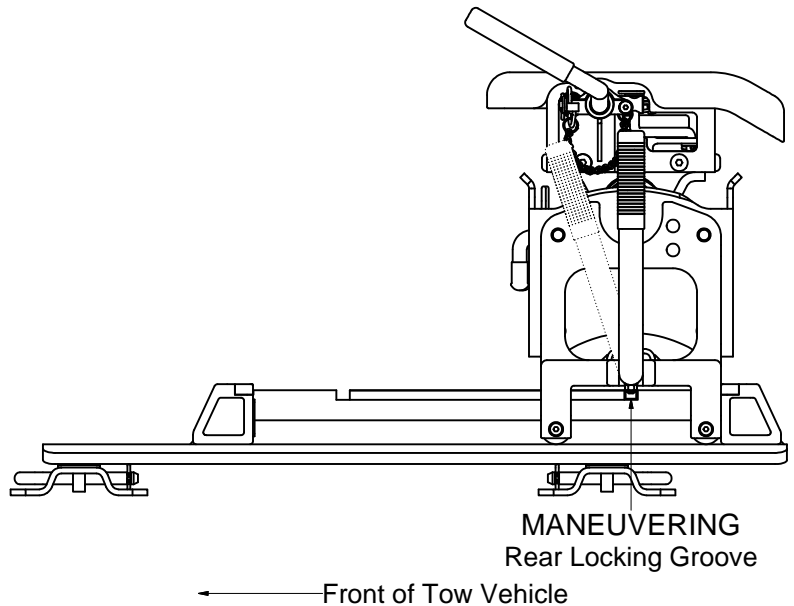

## TO TOW

1. Align trailer and tow vehicle in a straight line on a level surface.
2. Pull handle out and rotate clockwise to place lock bar in the ready to lock position.
3. Set trailer brakes and slowly back up the tow vehicle until **R20** roller stops. Lock bars will automatically engage in the Forward Locking Groove.
4. **NOTE:** Visually check that lock bar handle is vertical and both lock bars are fully engaged and that the green indicator is visible. Set trailer brakes and move the tow vehicle forward slightly to be sure both lock bars are fully engaged.
5. You are now ready to tow.

### TOWING POSITION

Roller and Hitch will move 12" FORWARD

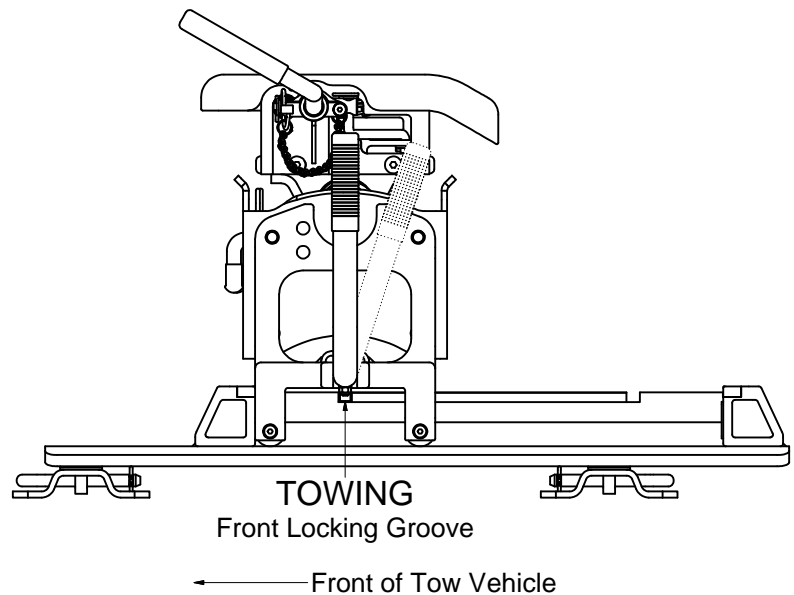

This product complies with **V-5** regulations and safety requirements for connecting devices and towing systems of the State of Wisconsin.

## **16515 / 16530 / 16550 REMOVAL**

1. For removal of the **16515** or **16530** fifth wheel head from the **16550 R20** Roller, reverse the steps found under the Fifth Wheel Head Installation on **page 5**. See Illustrations on **page 5**.
2. For removal of the **16550 R20** Roller, reverse steps 3-9 found under the **16550 R20** 5<sup>th</sup> Wheel Roller Installation Instructions on **page 4**. See Base Rail Hitch Pin Illustration & Illustration 3 found on **page 4**.

## **WARRANTY**

### **Limited 7 Year Warranty**

CURT Manufacturing LLC warrants, to the original purchaser, its products to be free from defect workmanship under normal use and service, ordinary wear and tear excepted for as long as product is owned by the original purchaser.

### **Limitations of the Warranty**

CURT Manufacturing LLC's obligation under this warranty is limited to repair or replacement, at its option. CURT Manufacturing LLC shall not be liable for the loss of or use of vehicles, cost of removal and /or installation, loss of time, inconvenience, rental of vehicles, loss or damage to personal property, expenses such as telephone, lodging, gasoline, towing, or any incidental or consequential damages. CURT Manufacturing LLC will examine the returned product. If the defect is covered under the warranty, CURT Manufacturing will repair the item or replace it at that time. Alterations or misuse of the items will not be covered under the warranty.

Some states do not allow the exclusion or limitation of incidental or consequential damages. So the above limitation or exclusion may not apply to you.

This warranty gives you specific legal rights and you may also have other rights, which vary, from state to state.

### **Obligations of Purchaser/Consumer**

The following steps need to be followed completely.

1. The purchaser/consumer must present proof of purchase of the defective CURT product to the headquarters of CURT Manufacturing LLC. Toll Free Number: 1-877-CURTMFG.
2. The purchaser/consumer must pay all handling charges and shipping charges incurred by the defective products to CURT Manufacturing LLC and for delivery of the replacement products by CURT Manufacturing LLC to the purchaser/consumer.

Curt Manufacturing, LLC.  
6208 Industrial Drive  
Eau Claire, WI 54701