

# INSTALLATION INSTRUCTIONS

**WARNING: NEVER EXCEED YOUR VEHICLE MANUFACTURER'S RECOMMENDED TOWING CAPACITY**

## CLAMP-ON BIKE RACK



### WARNINGS

Check straps for wear, and replace if worn.

This product is not intended for off-road use, tandems or recumbents.

Do not install on a trailer or other towed vehicle.

Check tightness of all bolts and knobs periodically.

### PARTS LIST

Item#	Qty	Description
1	1	Bike rack
2	1	Collapsing knob
3	6	Arm strap, rubber

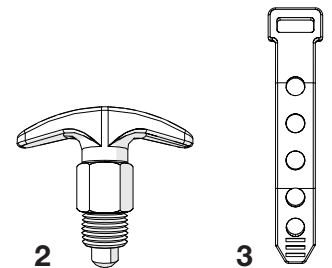
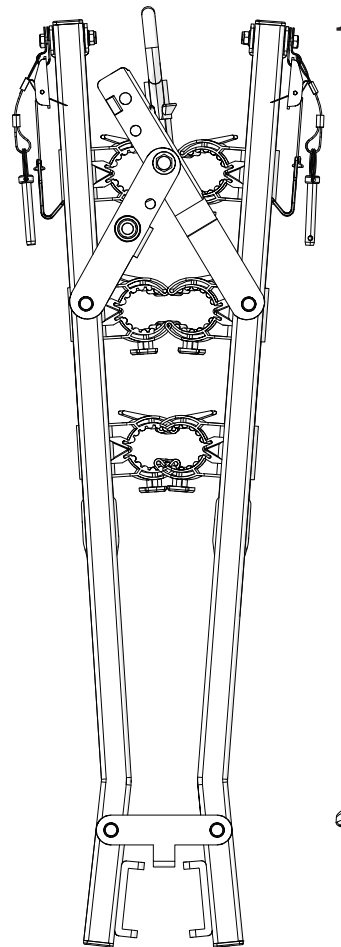

# ASSEMBLY & INSTALLATION

## Step 1

Insert the collapsing knob (#2) in the corresponding hole on the bike rack and turn clockwise to unlock the bike rack arm posts. Leave in until ready to store again. See figure 1. Raise the arm posts to the upright position. See figure 2.

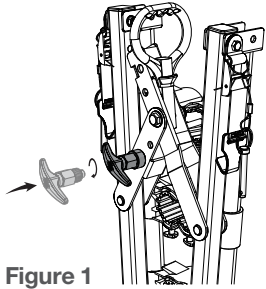

Figure 1

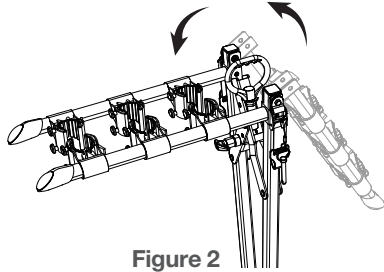

Figure 2

## Step 2

Adjust the bike clamps to the correct position for accepting bike frames. See figure 3. Insert the attached pin to lock the arm post in place before installation. See figure 4.

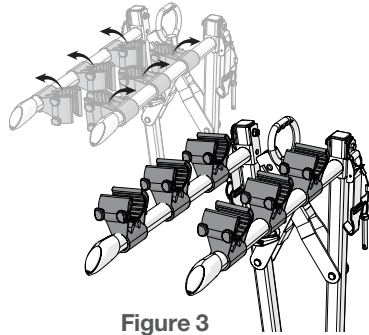

Figure 3

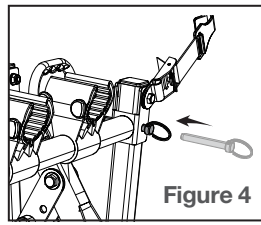

Figure 4

## Step 3

Securely clamp the bottom of the bike rack onto the shank of the ball mount. See the figures below.

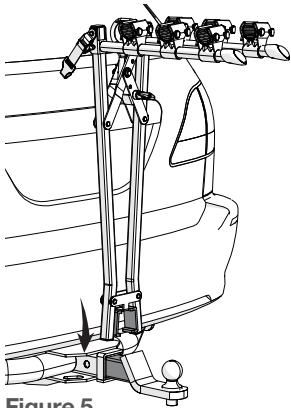

Figure 5

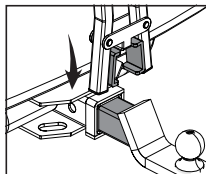

Figure 5-A

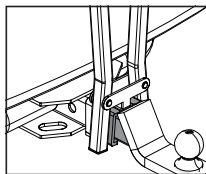

Figure 5-B

## Step 4

Loosen the collapsing knob (#2). Using the release handle, push down to spread the bike rack arms into the traveling position. Lock the collapsing knob (#2) into place.

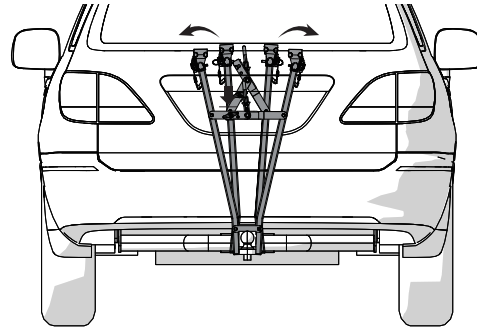

Figure 6

## Step 5

Install the safety support strap. Loop the straps onto each bike rack arm and cinch back to the connection to the hatch, as shown in the figure below. Secure the extra strap length.

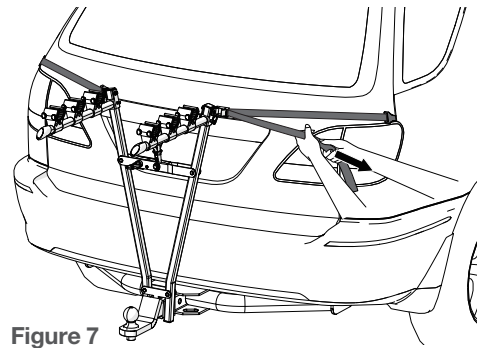

Figure 7

## Step 6

Install the bikes on the rack and secure with the provided rubber arm straps (#3). Be sure to secure the cross post and seat post to the rack. **Note:** When towing more than one bike, be sure to alternate the directions the bikes are facing on the rack. First bike faces right, 2nd bike faces left and so on. See the figure below.

