

INSTALLATION INSTRUCTIONS

WARNING: NEVER EXCEED YOUR VEHICLE MANUFACTURER'S RECOMMENDED TOWING CAPACITY

FIXED, HITCH-MOUNTED CARGO CARRIER



PARTS LIST

Item#	Qty	Description
1	18	Locknut, M6
2	18	Flat washer, M6
3	6	Support bracket, V-shape
4	2	Platform, bottom half
5	4	Locknut, M10
6	4	Spring washer, M10
7	4	Flat washer, M10*1.5
8	8	Hex head bolt, M8*35
9	1	Shank, 1 1/4"
10	4	Hex head bolt, M10*60
11	18	Hex head bolt, M6*35
12	2	Platform, top tubing
13	8	Locknut, M8
14	8	Flat washer, M8
15	2	Connection tube
16	1	Clip
17	1	Hex head bolt, 1/2" - 13
18	1	Flat washer, 1/2"
19	1	Star washer, 1/2"
20	1	U-type adapter

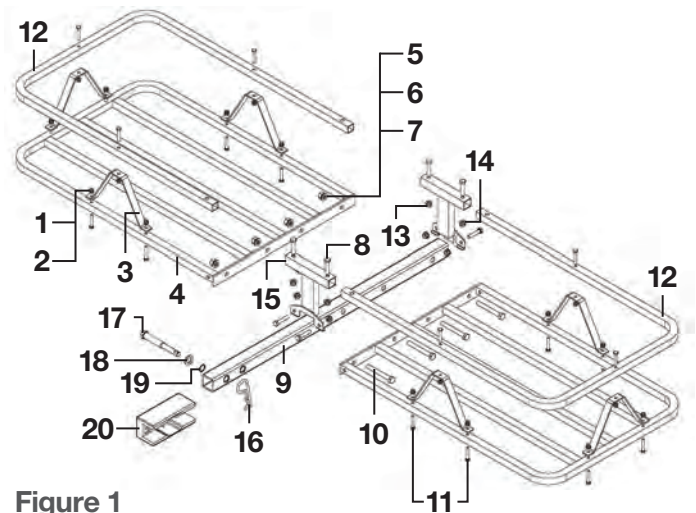

Figure 1

SUGGESTED TOOLS

Adjustable wrench, 0 to 30mm



WARNINGS

Do not exceed maximum weight capacity of 500 lbs. when using 2" receiver tube and 300 lbs. when using an 1 1/4" receiver tube. Distribute the weight evenly on platform when hauling a load. **NOTE:** This carrier is not intended for transporting people.

Do not carry loads wider or deeper than carrier. Do not carry flammable items on carrier. Do not allow exhaust fumes to blow directly on items. This is a fire hazard.

CURT Manufacturing, LLC is not responsible for any damage if warnings are not heeded.

ASSEMBLY

Step 1

Lay down the bottom platform (#4). The tube must be flush with top of plate for correct assembly. Assemble support brackets (#3) on platform half (#4) with M6*35 hex head bolt (#11), M6 flat washer (#2) and M6 locknut (#1) to 80% tightness. Connect the top platform tubing (#12) to the support bracket (#3) using the same hardware listed above. Repeat with other platform half (#4) and tubing (#12).

Step 2

Align the holes on assembled platforms with the 1 1/4" shank (#9). Secure with M10*60 hex head bolt (#10), M10 spring washer (#6), M10*1.5 flat washer (#7) and M10 locknut (#5) to 80% tightness.

Lock the shank (#9) with connection tube (#15), then assemble top platform tubing (#12) into the connection tubing and secure with M8*35 hex head bolts (#8), M8 flat washer (#14) and M8 locknut (#13) to 80% tightness.

NOTE: The connection tube with reflective tape should be located on the side facing away from the vehicle. The one without tape should be located on the shank side.

Step 3

Fully tighten all of the bolts and locknuts.

Step 4

Insert the cargo carrier shank into the vehicle's receiver tube. Secure with 1/2" hex head bolt (#17), flat washer (#18), star washer (#19) and clip (#16).

Step 5

To adapt the 1 1/4" shank to a 2" shank, assemble the U-type adapter (#20) onto the 1 1/4" shank (#9). Align the holes and secure with 1/2" hex head bolt (#17), flat washer (#18), star washer (#19) and clip (#16).

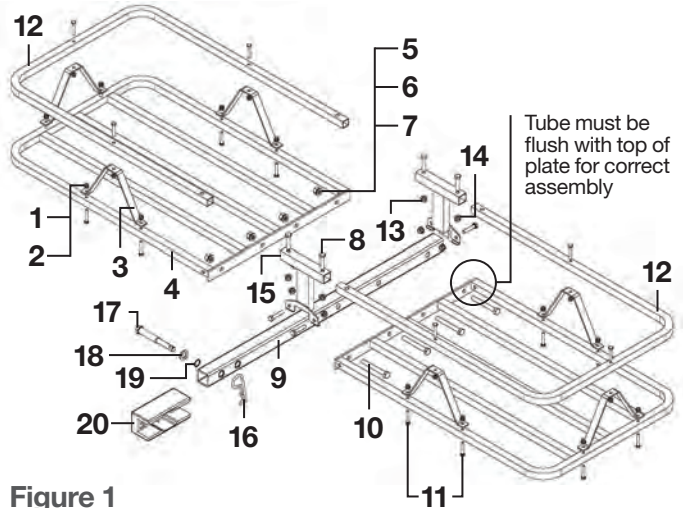

Figure 1