



31018 INSTALLATION INSTRUCTIONS



Safety glasses should be worn at all times while installing this product.

YEARS: 2011-CURRENT

MAKE: FORD

MODEL: SUPER DUTY

STYLE: TRUCK

WARNING: NEVER EXCEED YOUR VEHICLE MANUFACTURER'S RECOMMENDED TOWING CAPACITY







WEIGHT CARRYING:
TRAILER WEIGHT: 5,000 LBS.
TONGUE WEIGHT: 500 LBS.

GROSS LOAD CAPACITY WHEN USED AS A STRAIGHT LINE PULL:
9,000 LBS MAX.

INSTALLATION TIME: 30-60 MIN.

THE INSTALL TIME LISTED IS FOR PROFESSIONAL INSTALLERS. IF YOU ARE HESITANT TO UNDERTAKE THIS TASK ON YOUR OWN, CONTACT AN AUTHORIZED CURT INSTALLER FOR ADDITIONAL ASSISTANCE.



INSTALLATION REQUIRES:

 RATCHET	 SAFETY GLASSES	 3/4" 18mm SOCKET
 TORQUE WRENCH	 ROTARY TOOL	 MARKER
 TAPE MEASURE		

INSTALLATION TIPS:

- BEFORE YOU BEGIN INSTALLATION, READ ALL INSTRUCTIONS THOROUGHLY.
- TO EASE INSTALLATION, 2 PEOPLE MAY BE REQUIRED.
- USING PROPER TOOLS WILL GREATLY IMPROVE THE QUALITY OF THE INSTALL AND REDUCE THE TIME REQUIRED.
- NEED HELP OR HAVE SOME QUESTIONS? CALL TECHNICAL SUPPORT AT 800.798.0813

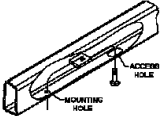
LEVEL OF DIFFICULTY: MODERATE

EASY	MODERATE	HARD
	FISHWIRE 1/2" CARRIAGE BOLTS AND CM-SP10 SPACERS FISHWIRE BOLT PLATES	
	REMOVE FASCIA BRACKETS	
	TRIM FASCIA IF INSTALLED IN RISE POSITION	

VEHICLE PHOTO:



REPRESENTATIVE PHOTO

HITCH ILLUSTRATION:

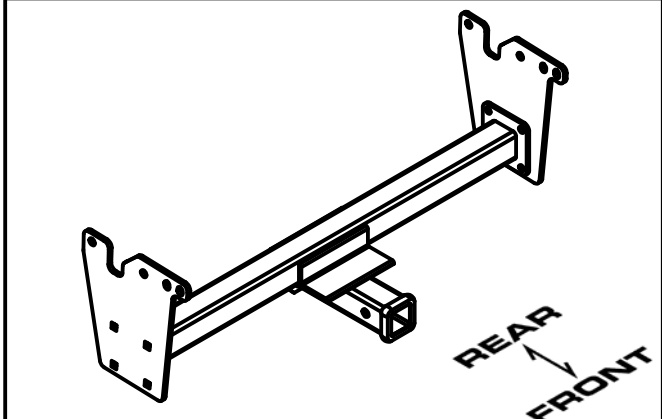

MAKE SURE YOUR HITCH MATCHES

PERIODICALLY CHECK THIS RECEIVER HITCH TO ENSURE ALL FASTENERS ARE TIGHT AND ALL STRUCTURAL COMPONENTS ARE SOUND

CURT Manufacturing Inc. warrants this product to be free of defects in material and/or workmanship at the time of retail purchase by the original purchaser. If the product is found to be defective, Curt Manufacturing Inc. may repair or replace the product at their option, when the product is returned, prepaid, with proof of purchase. Alteration to, misuse of, or improper installation of this product voids the warranty. Curt Manufacturing Inc.'s liability is limited to repair or replacement of products found to be defective, and specifically excludes liability for incidental or consequential loss or damage.

For more information log onto www.curtmfg.com, & for helpful towing tips log onto www.hitchinfo.com

INSTALLATION WALKTHROUGH:

Parts List			
ITEM	QTY	PART NUMBER	DESCRIPTION
1	16	HFN 1213	HEX FLANGE NUT
2	16	1/2-13 x 1 1/2	CARRIAGE BOLT
3	8	CM-SP10	.250 x 1.00 x 2.50" SQUARE HOLE SPACER
4	4	1_2 FISHWIRE	1/2" FISHWIRE
5	2	CM-31018-SP	.313" SIDE PLATE

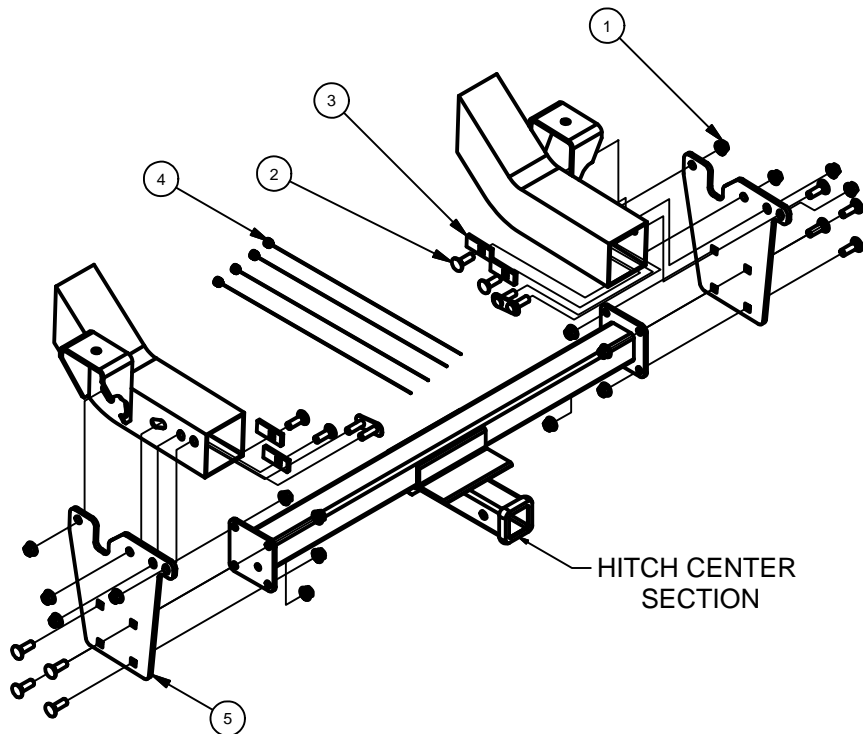

1. Use 18mm socket and ratchet to remove driver and passenger side tie down brackets if present. Existing bolt plates will fall out of front of frame rails.



2. Return fascia brackets to vehicle owner. Fishwire the (2) remaining bolt plates through original holes on outside of frame rails. NOTE: If bolt plates are not present, use additionally supplied fasteners.



INSTALLATION WALKTHROUGH:

3. Raise side plates into position and install (4) hex flange nuts onto existing bolt plates. Fishwire supplied (2) 1/2-13 x 1 1/2" carriage bolts and CM-SP10 spacers through front of driver and passenger side frame rails and out round holes in side plates. Install supplied 1/2-13 hex flange nuts onto carriage bolts.

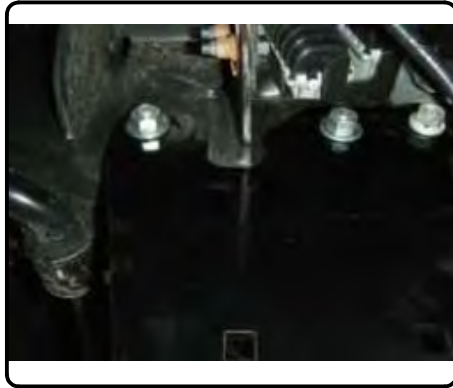

4. The hitch center section can be installed in a raised or lowered position. The lowered position will extend below the vehicle front fasci while the raise position will required fascia trimming.

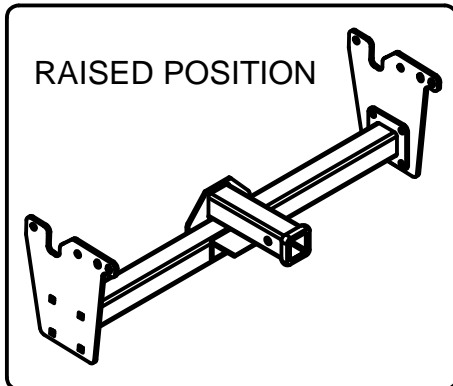
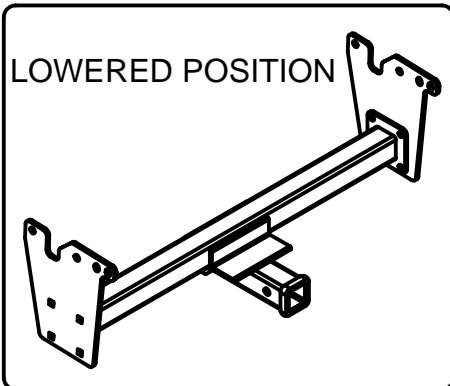

For more information log onto www.curtmfg.com, & for helpful towing tips log onto www.hitchinfo.com

5a. If hitch is being installed in the lowered position, raise center section between side plates and install supplied 1/2-13 x 1 1/2" carriage bolts through side plates. Secure the center section with supplied 1/2" hex flange nuts.

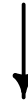

5b. If hitch is being installed in the rise position, hold center section in position and mark where the receiver tube will protrude through the fasci. Use a rotary tool to carefully cut the plastic fasci. When trimming is complete, install the center section using supplied 1/2-13 x 1 1/2" carriage bolts and 1/2" hex flange nuts.

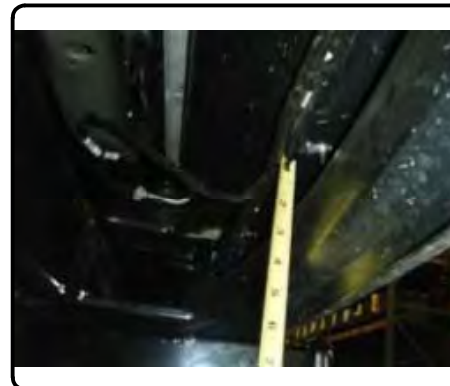

RECEIVER TUBE IN RAISED POSITION SHOULD BE APPROXIMATELY 5" HIGHER THAN IN LOWERED POSITION.

INSTALLATION WALKTHROUGH:

6. Torque 1/2-13" hardware to 110 lb-ft and M12-1.75 hardware to 86 lb-ft.



*****DO NOT EXCEED VEHICLE MANUFACTURER'S RECOMMENDED TOWING CAPACITY ***.**

FRONT MOUNTED ACCESSORIES

1) Do not exceed front axle Gross Weight Rating (GAWR). Consult owners manual or specification plate located on driver's door frame. Measure gross front axle weight by placing front wheels of loaded vehicle on a scale.

WARNING: Exceeding GAWR may overload the front axle and/or suspension. This could result in **accident, property damage and personal injury.**

2) Reposition front mounted license plate if obstructed.

3) Do not obstruct vehicle lights.

4) Allow free air flow into grille opening.

5) Rear wheel traction may be reduced. This could effect handling. Reduce speed and drive with caution.

6) Accessories extend front of vehicle. This may reduce approach angle. Use caution when parking and maneuvering.

7) Do not obstruct driver view.

VEHICLE RECOVERY AND WINCHING TIPS

1) Use OEM tow hooks, recovery eyes or a clevis mount for attachment of a tow strap or winch cable.

WARNING: NEVER use a ball and/or ball mount as an anchor point for tow strap or winch cable. Severe personal injury or death could result.

2) Observe winch manufacturer's recommendations, cautions and warnings.

3) Attach return cable to tow hook or recovery eye when using a snatch block (See figure 1).

CAUTION: Do not attach return cable to winch mount. This may overload winch mount and/or front mounted receiver.

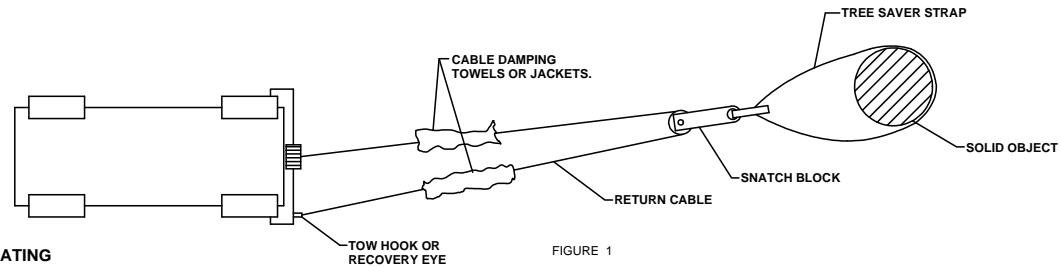

RATING

For **Maximum** line pull rating, winch cable must not exceed:

- 15 degree angle up or down from horizontal (See Figure 2).
- 45 degree angle left or right from straight ahead (See Figure 3).

CAUTION: Exceeding the maximum line pull rating may over load winch, winch mount, and/or front mounted receiver.

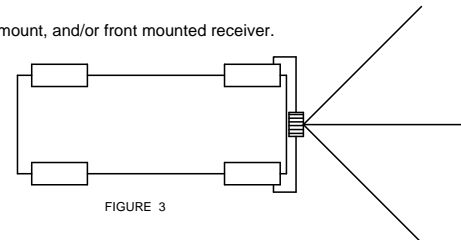
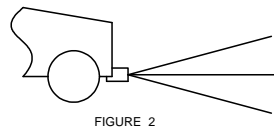

31018

FORD F-250 / F-350 SUPER DUTY 4x4

4/1/2014

GROSS LOAD CAPACITY WHEN USED AS A WEIGHT CARRYING HITCH: 5,000 LBS. TRAILER WEIGHT & 500 LBS. TONGUE WEIGHT.

GROSS LOAD CAPACITY WHEN USED AS A STRAIGHT LINE PULL: 9,000 LBS. MAX. LINE PULL.

*** DO NOT EXCEED VEHICLE MANUFACTURER'S RECOMMENDED TOWING CAPACITY. ***

HAVING INSTALLATION QUESTIONS? CALL TECHNICAL SUPPORT AT 1-800-798-0813

Parts List

ITEM	QTY	PART NUMBER	DESCRIPTION
1	16	HFN 1213	HEX FLANGE NUT
2	16	1/2-13 x 1 1/2	CARRIAGE BOLT
3	8	CM-SP10	.250 x 1.00 x 2.50" SQUARE HOLE SPACER
4	4	1_2 FISHWIRE	1/2" FISHWIRE
5	2	CM-31018-SP	.313" SIDE PLATE

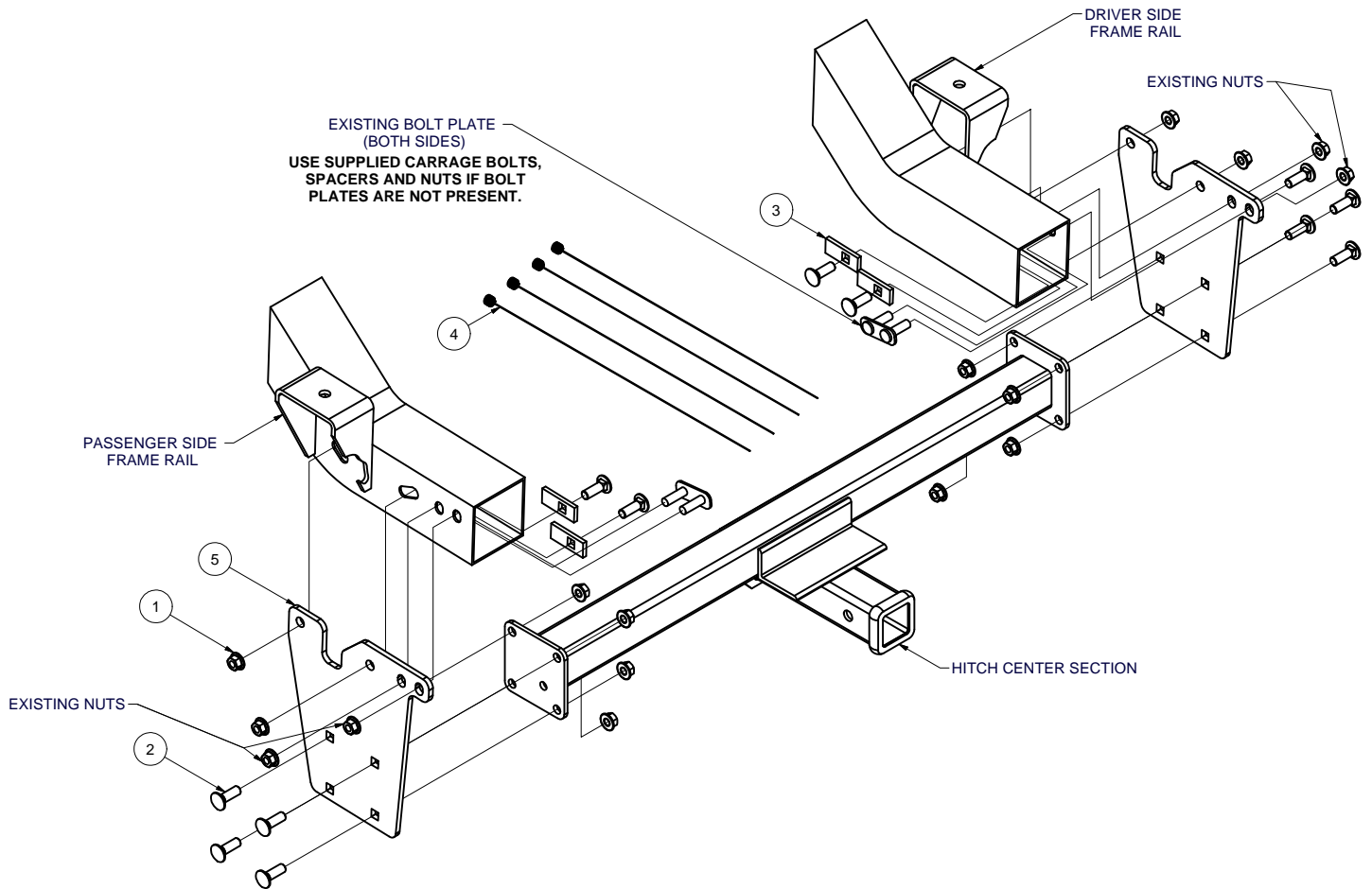

HITCH WEIGHT: 43 LBS.

INSTALL TIME

PROFESSIONAL: 30-60 MINUTES

NOVICE (DIY): 60-120 MINUTES

INSTALL NOTES:

- NO DRILLING REQUIRED
- REMOVE EXISTING BRACKETS
- FISHWIRE HARDWARE
- FASCIA TRIMMING MAY BE REQUIRED



PERIODICALLY CHECK THIS RECEIVER HITCH TO ENSURE THAT ALL FASTENERS ARE TIGHT AND THAT ALL STRUCTURAL COMPONENTS ARE SOUND.

Curt Manufacturing Inc., warrants this product to be free of defects in material and/or workmanship at the time of retail purchase by the original purchaser. If the product is found to be defective, Curt Manufacturing Inc., may repair or replace the product, at their option, when the product is returned, prepaid, with proof of purchase. Alteration to, misuse of, or improper installation of this product voids the warranty. Curt Manufacturing Inc.'s liability is limited to repair or replacement of products found to be defective, and specifically excludes liability for incidental or consequential loss or damage.

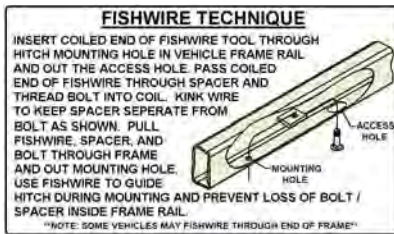
31018**FORD F-250 / F-350 SUPER DUTY 4x4**

TOOLS REQUIRED
SOCKET WRENCH
3/4" SOCKET
18mm SOCKET
TORQUE WRENCH
ROTARY TOOL
CUTOFF WHEEL

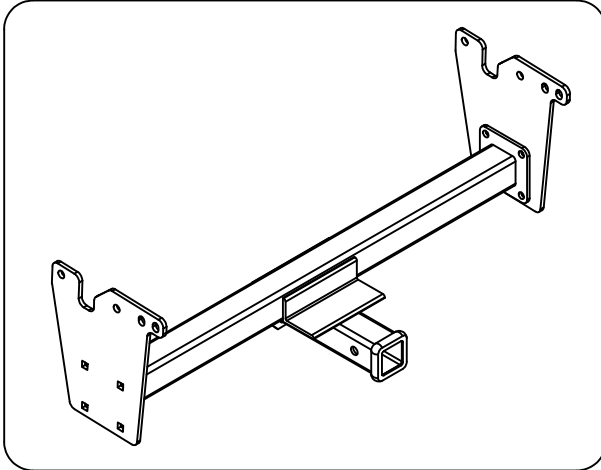

LOWERED POSITION

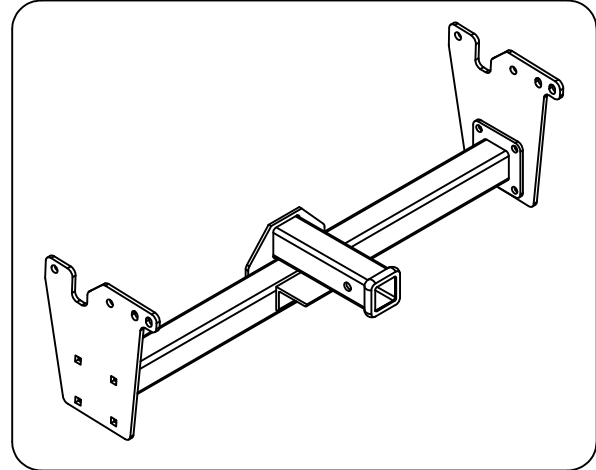
RAISED POSITION
(FASCIA TRIMMING REQUIRED)**INSTALLATION STEPS**

1. Remove (2) existing fascia brackets. The fascia brackets are held in place with bolt plates. Remove the bolt plates from the front of the frame rails. Return brackets to vehicle owner.
2. Fishwire (2) of the original bolt plates through ends of frame rails and out original holes on outside of frame rails. Raise CM-31018-SP plates into position over bolts and secure the plates with the (4) remaining hex nuts as shown. NOTE: If bolt plates are not present, use additionally supplied fasteners.
3. Fishwire 1/2-13 x 1 1/2" carriage bolts and CM-SP10 spacers through front of frame rails and out round holes in CM-31018-SP plates. Secure the carriage bolts with supplied hex flange nuts.
4. The hitch center section can be installed in a raised or lowered position. The lowered position will extend below the plastic front fascia while the raised position will require trimming the fascia.
- 5a. If the hitch is being installed in the lowered position, raise the hitch center section between the side plates and install the supplied 1/2-13 x 1 1/2" carriage bolts as shown. Secure the carriage bolts with hex flange nuts.
- 5b. If the hitch is being installed in the raised position, raise the hitch center section between the side plates and mark the fascia where it will be trimmed around the receiver tube. Carefully trim the fascia to the desired clearance.
Note: The receiver tube in the raised position will be approximately 5" above the lowered position.
6. Torque all 1/2" hardware to 110 lb-ft and M12 hardware to 86 lb-ft.

PERIODICALLY CHECK THIS RECEIVER HITCH TO ENSURE THAT ALL FASTENERS ARE TIGHT AND THAT ALL STRUCTURAL COMPONENTS ARE SOUND.

Curt Manufacturing Inc., warrants this product to be free of defects in material and/or workmanship at the time of retail purchase by the original purchaser. If the product is found to be defective, Curt Manufacturing Inc., may repair or replace the product, at their option, when the product is returned, prepaid, with proof of purchase. Alteration to, misuse of, or improper installation of this product voids the warranty. Curt Manufacturing Inc.'s liability is limited to repair or replacement of products found to be defective, and specifically excludes liability for incidental or consequential loss or damage.

*****DO NOT EXCEED VEHICLE MANUFACTURER'S RECOMMENDED TOWING CAPACITY*****.

FRONT MOUNTED ACCESSORIES

1) Do not exceed front axle Gross Weight Rating (GAWR). Consult owners manual or specification plate located on driver's door frame. Measure gross front axle weight by placing front wheels of loaded vehicle on a scale.

WARNING: Exceeding GAWR may overload the front axle and/or suspension. This could result in **accident, property damage and personal injury.**

- 2) Reposition front mounted license plate if obstructed.
- 3) Do not obstruct vehicle lights.
- 4) Allow free air flow into grille opening.
- 5) Rear wheel traction may be reduced. This could effect handling. Reduce speed and drive with caution.
- 6) Accessories extend front of vehicle. This may reduce approach angle. Use caution when parking and maneuvering.
- 7) Do not obstruct driver view.

VEHICLE RECOVERY AND WINCHING TIPS

1) Use OEM tow hooks, recovery eyes or a clevis mount for attachment of a tow strap or winch cable.

WARNING: NEVER use a ball and/or ball mount as an anchor point for tow strap or winch cable. Severe personal injury or death could result.

- 2) Observe winch manufacturer's recommendations, cautions and warnings.
- 3) Attach return cable to tow hook or recovery eye when using a snatch block (See figure 1).

CAUTION: Do not attach return cable to winch mount. This may overload winch mount and/or front mounted receiver.

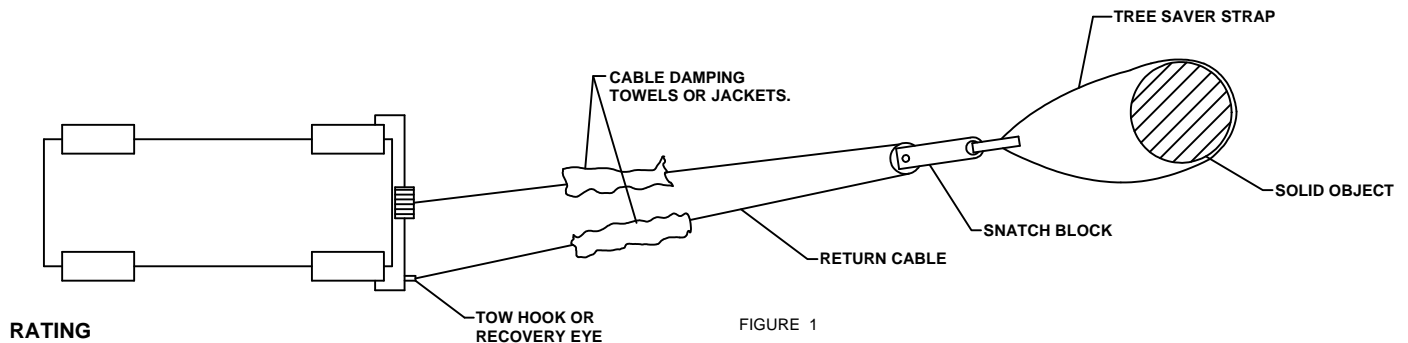

RATING

For **Maximum** line pull rating, winch cable must not exceed:

- 15 degree angle up or down from horizontal (See Figure 2).
- 45 degree angle left or right from straight ahead (See Figure 3).

CAUTION: Exceeding the maximum line pull rating may over load winch, winch mount, and/or front mounted receiver.

