



# 31022 INSTALLATION INSTRUCTIONS



Safety glasses should be worn at all times while installing this product.

YEARS: 2002-07

MAKE: JEEP

MODEL: LIBERTY 4X4

STYLE: SUV

**WARNING: NEVER EXCEED YOUR VEHICLE MANUFACTURER'S RECOMMENDED TOWING CAPACITY**

**WEIGHT CARRYING:**  
TRAILER WEIGHT: 3,500 LBS.  
TONGUE WEIGHT: 350 LBS.

**GROSS LOAD CAPACITY WHEN USED AS A STRAIGHT LINE PULL:**  
9,000 LBS MAX.

**INSTALLATION TIME: 30 MIN.**

THE INSTALL TIME LISTED IS FOR PROFESSIONAL INSTALLERS. IF YOU ARE HESITANT TO UNDERTAKE THIS TASK ON YOUR OWN, CONTACT AN AUTHORIZED CURT INSTALLER FOR ADDITIONAL ASSISTANCE.



### INSTALLATION TIPS:

1. BEFORE YOU BEGIN INSTALLATION, READ ALL INSTRUCTIONS THOROUGHLY.
2. TO EASE INSTALLATION, 2 PEOPLE MAY BE REQUIRED.
3. USING PROPER TOOLS WILL GREATLY IMPROVE THE QUALITY OF THE INSTALL AND REDUCE THE TIME REQUIRED.
4. NEED HELP OR HAVE SOME QUESTIONS? CALL TECHNICAL SUPPORT AT 800.798.0813

### INSTALLATION REQUIRES:

 RATCHET	 TORQUE WRENCH	 10" SOCKET EXTENSION
 11/16" 10mm SOCKET	 BOXED END WRENCH 11/16"	 DRILL BIT 1/2"
 POWER DRILL	 DIE GRINDER	 AVIATION SHEARS
 SCREW DRIVER		

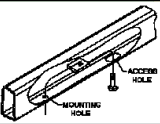
### LEVEL OF DIFFICULTY: HARD

EASY	MODERATE	HARD
	- FISHWIRE HARDWARE	
	- TRIM WHEEL WELL	
	- REMOVE AIR DAM	

### VEHICLE PHOTO:



REPRESENTATIVE PHOTO

### HITCH ILLUSTRATION:

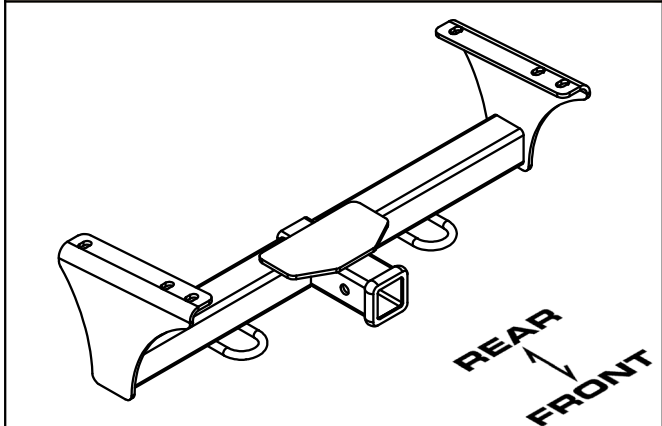

MAKE SURE YOUR HITCH MATCHES

**PERIODICALLY CHECK THIS RECEIVER HITCH TO ENSURE ALL FASTENERS ARE TIGHT AND ALL STRUCTURAL COMPONENTS ARE SOUND**

CURT Manufacturing Inc. warrants this product to be free of defects in material and/or workmanship at the time of retail purchase by the original purchaser. If the product is found to be defective, Curt Manufacturing Inc. may repair or replace the product at their option, when the product is returned, prepaid, with proof of purchase. Alteration to, misuse of, or improper installation of this product voids the warranty. Curt Manufacturing Inc.'s liability is limited to repair or replacement of products found to be defective, and specifically excludes liability for incidental or consequential loss or damage.

For more information log onto [www.curtmfg.com](http://www.curtmfg.com), & for helpful towing tips log onto [www.hitchinfo.com](http://www.hitchinfo.com)

## INSTALLATION WALKTHROUGH:

Parts List			
ITEM	QTY	PART NUMBER	DESCRIPTION
1	6	CM-SP11	.250 x 1.00 x 2.50" SQUARE HOLE SPACER
2	6	7/16-14 x 1 1/2	CARRIAGE BOLT
3	2	7_16 FISHWIRE	7/16" FISHWIRE
4	6	7/16-14	HEX FLANGE NUT

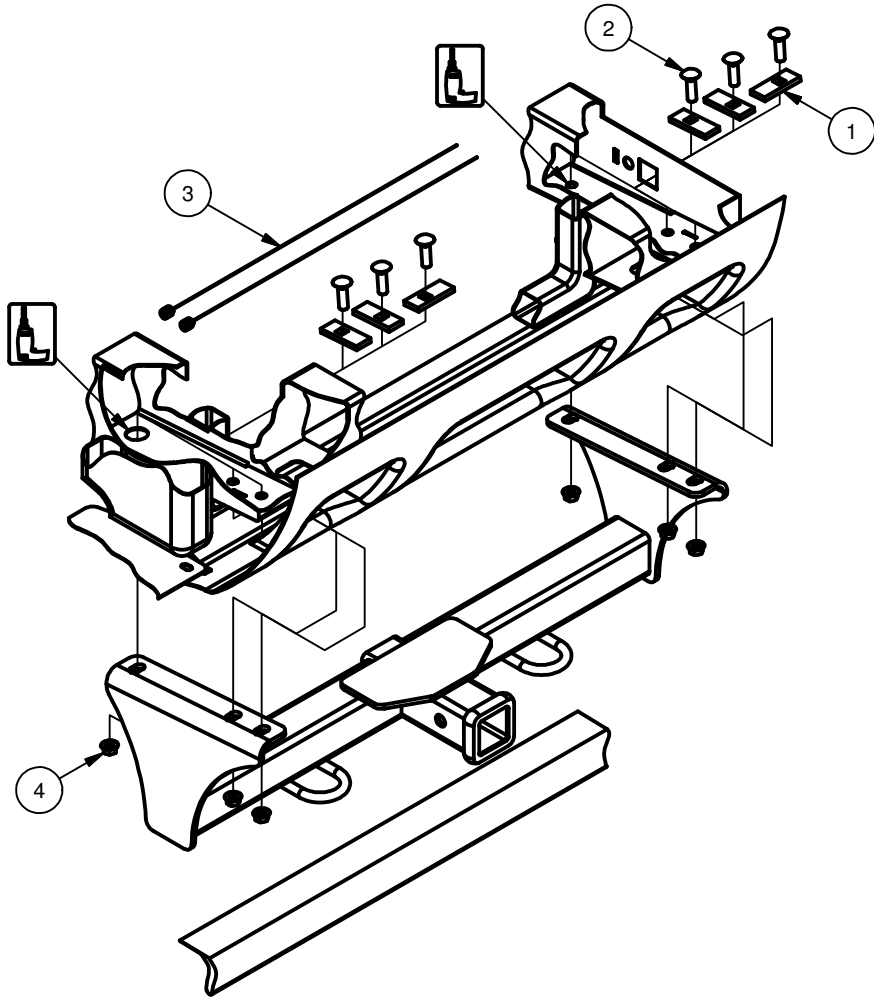

1. Remove air dam and return to owner, air dam is secured with (5) rivet type fasteners and (2) screws.  
**Note:** You will have to cut off the rivet type fasteners.

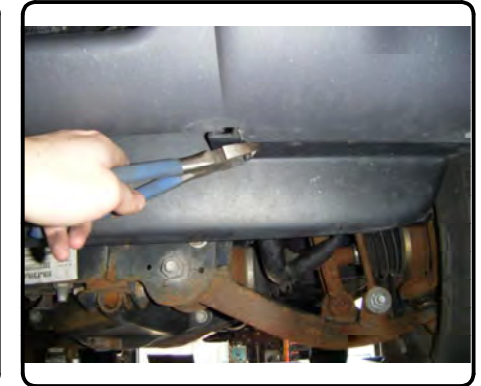

2. Mark and trim the plastic wheel well. **Note:** Dimensions are approximate, confirm fit before trimming.

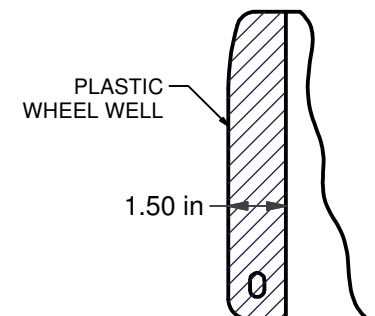

## INSTALLATION WALKTHROUGH:

3. Raise hitch into position aligning the forward most holes in the hitch with the (2) existing holes in frame rails. When holes are aligned and hitch is square mark the drill holes and lower hitch. **Note:** When raising and lowering the hitch pull back on the bumper cover and rotate the front of the hitch up.

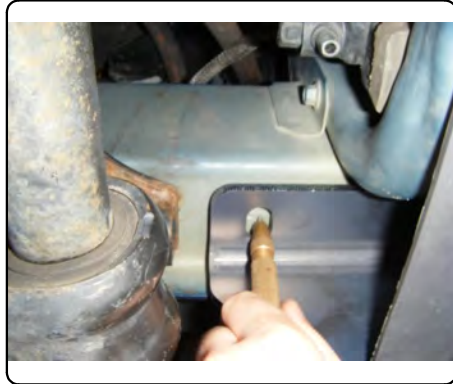

4. Drill holes marked in Step (3). Enlarge the drill hole in the passenger side frame rail to allow 7/16" carriage bolts and SP11 spacers to pass through. **Note:** If existing access hole is not present in driver side frame rail, enlarge the drill hole to allow 7/16" carriage bolts and SP11 spacers to pass through.

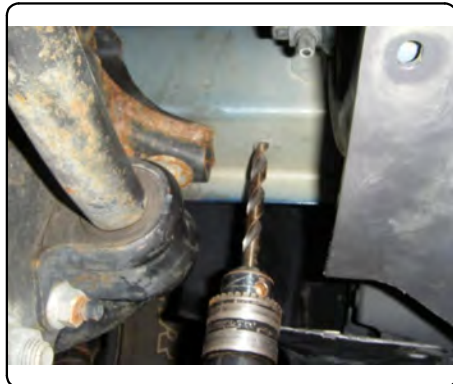
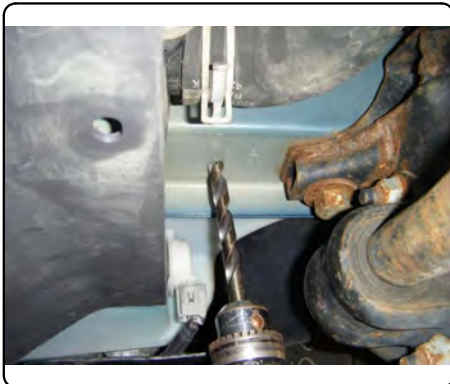

5. Fishwire 7/16-14 x 1 1/2" carriage bolts and SP11 spacers through the access holes and out the (3) holes in the drivers side frame rail ((2) holes if it is a drilled access hole) and (2) holes in the passenger side frame rail. (See Fishwire Technique)

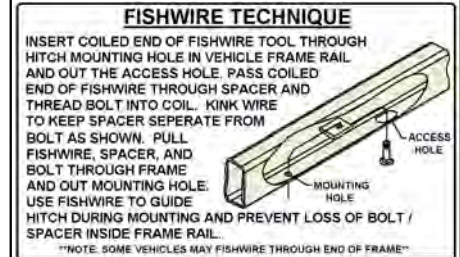

6. Reverse fishwire 7/16-14 x 1 1/2" carriage bolt and SP11 spacer into the drilled access hole in the passenger frame rail (and driver side frame rail if it is a drilled access hole).

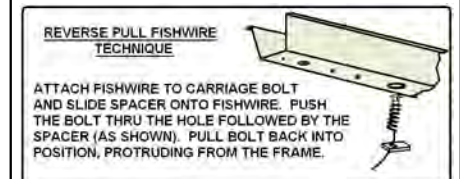



## INSTALLATION WALKTHROUGH:

7. Raise hitch into position, careful not to push the bolts into the frame rails, and secure using 7/16" flange nuts.



8. Reinstall the (2) screws removed in Step (1) and secure the bumper cover to the radiator support bracket.

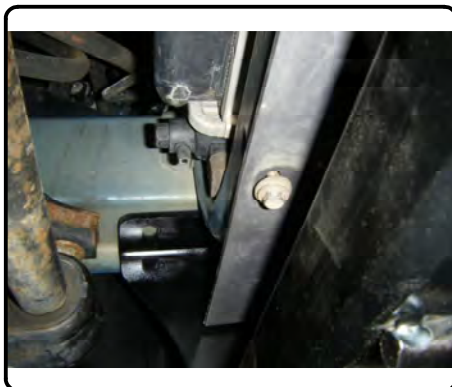

9. Torque all 7/16" hardware to 70 ft-lbs.



10. Hitch installation is complete.



31022

2002-07 JEEP LIBERTY 4X4

11/12/2012

GROSS LOAD CAPACITY WHEN USED AS A WEIGHT CARRYING HITCH: 3,500 LBS. TRAILER WEIGHT & 350 LBS. TONGUE WEIGHT.

GROSS LOAD CAPACITY WHEN USED AS A STRAIGHT LINE PULL: 9,000 LBS. MAX. LINE PULL.

\*\*\* DO NOT EXCEED VEHICLE MANUFACTURER'S RECOMMENDED TOWING CAPACITY. \*\*\*

HAVING INSTALLATION QUESTIONS? CALL TECHNICAL SUPPORT AT 1-800-798-0813

Parts List			
ITEM	QTY	PART NUMBER	DESCRIPTION
1	6	7/16-14	HEX FLANGE NUT
2	2	7_16 FISHWIRE	7/16" FISHWIRE
3	6	7/16-14 x 1 1/2	CARRIAGE BOLT
4	6	CM-SP11	.250 x 1.00 x 2.50" SQUARE HOLE SPACER

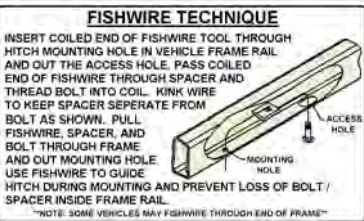

TOOLS REQUIRED	
RATCHET	
TORQUE WRENCH	
10" EXTENSION	
11/16" WRENCH	
11/16" SOCKET	
10mm SOCKET	
DRILL	
AVIATION SHEARS	
DIE GRINDER	

HITCH WEIGHT: .33 LBS.  
 INSTALL TIME  
 PROFESSIONAL: .30 MINUTES  
 NOVICE (DIY): .60 MINUTES  
 INSTALL NOTES:  
 - DRILLING REQUIRED  
 - FISHWIRE HARDWARE  
 - AIR DAM REMOVAL REQUIRED

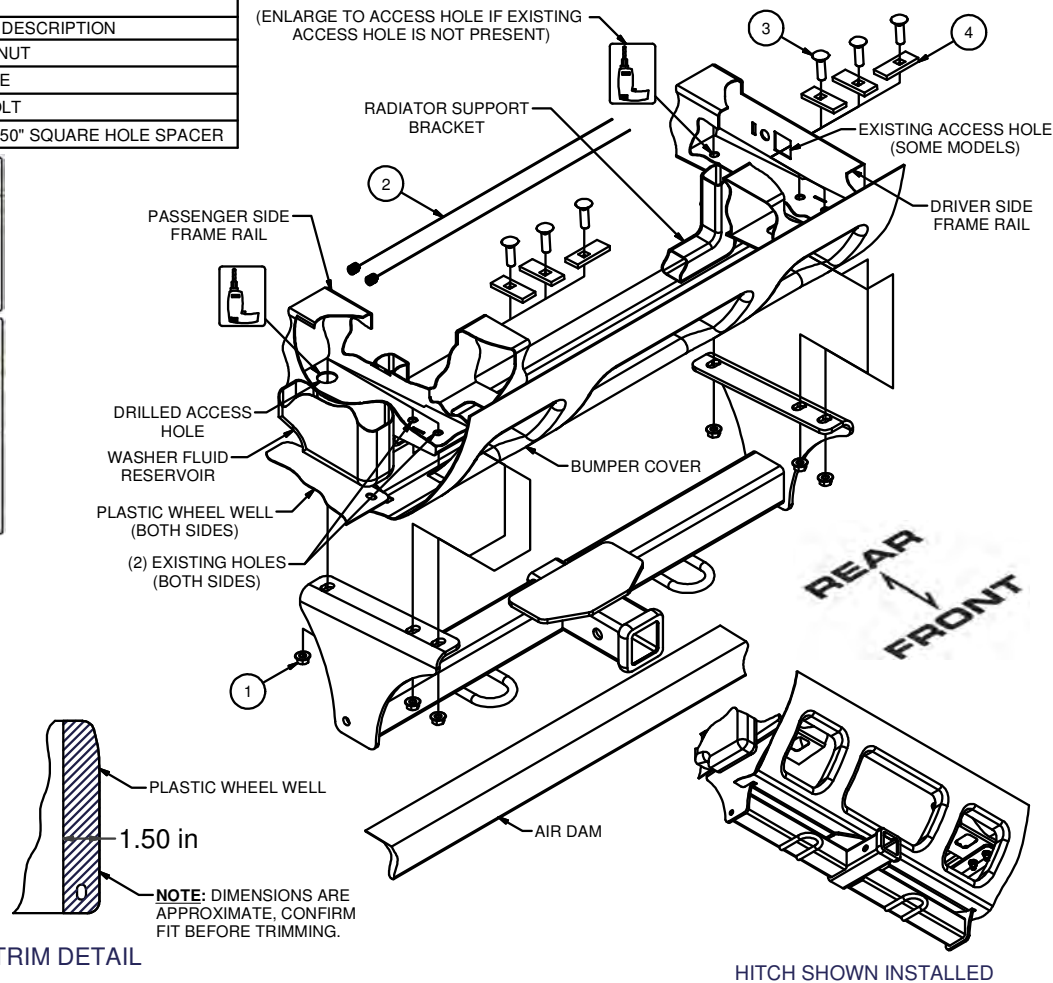

**INSTALLATION STEPS**

1. Remove air dam and return to owner, air dam is secured with (5) rivet type fasteners and (2) screws. **Note:** You will have to cut off the rivet type fasteners.
2. Mark and trim the plastic wheel well. (See trim detail)
3. Raise hitch into position aligning the forward most holes in the hitch with the (2) existing holes in frame rails. When holes are aligned and hitch is square mark the drill holes and lower hitch. **Note:** When raising and lowering the hitch pull back on the bumper cover and rotate the front of the hitch up.
4. Drill holes marked in Step (3). Enlarge the drill hole in the passenger side frame rail to allow 7/16" carriage bolts and SP11 spacers to pass through. **Note:** If existing access hole is not present in driver side frame rail, enlarge the drill hole to allow 7/16" carriage bolts and SP11 spacers to pass through.
5. Fishwire 7/16-14 x 1 1/2" carriage bolts and SP11 spacers through the access holes and out the (3) holes in the drivers side frame rail ((2) holes if it is a drilled access hole) and (2) holes in the passenger side frame rail. (See Fishwire Technique)
6. Reverse fishwire 7/16-14 x 1 1/2" carriage bolt and SP11 spacer into the drilled access hole in the passenger frame rail (and driver side frame rail if it is a drilled access hole).
7. Raise hitch into position, careful not to push the bolts into the frame rails, and secure using 7/16" flange nuts.
8. Reinstall the (2) screws removed in Step (1) and secure the bumper cover to the radiator support bracket.
9. Torque all 7/16" hardware to 70 ft-lbs.

**PERIODICALLY CHECK THIS RECEIVER HITCH TO ENSURE THAT ALL FASTENERS ARE TIGHT AND THAT ALL STRUCTURAL COMPONENTS ARE SOUND.**

Curt Manufacturing Inc., warrants this product to be free of defects in material and/or workmanship at the time of retail purchase by the original purchaser. If the product is found to be defective, Curt Manufacturing Inc., may repair or replace the product, at their option, when the product is returned, prepaid, with proof of purchase. Alteration to, misuse of, or improper installation of this product voids the warranty. Curt Manufacturing Inc.'s liability is limited to repair or replacement of products found to be defective, and specifically excludes liability for incidental or consequential loss or damage.

# 2002-07 JEEP LIBERTY 4X4

**\*\*\*DO NOT EXCEED VEHICLE MANUFACTURER'S RECOMMENDED TOWING CAPACITY \*\*\*.**

## FRONT MOUNTED ACCESSORIES

1) Do not exceed front axle Gross Weight Rating (GAWR). Consult owners manual or specification plate located on driver's door frame. Measure gross front axle weight by placing front wheels of loaded vehicle on a scale.

**WARNING:** Exceeding GAWR may overload the front axle and/or suspension. This could result in **accident, property damage and personal injury.**

- 2) Reposition front mounted license plate if obstructed.
- 3) Do not obstruct vehicle lights.
- 4) Allow free air flow into grille opening.
- 5) Rear wheel traction may be reduced. This could effect handling. Reduce speed and drive with caution.
- 6) Accessories extend front of vehicle. This may reduce approach angle. Use caution when parking and maneuvering.
- 7) Do not obstruct driver view.

## VEHICLE RECOVERY AND WINCHING TIPS

1) Use OEM tow hooks, recovery eyes or a clevis mount for attachment of a tow strap or winch cable.

**WARNING: NEVER** use a ball and/or ball mount as an anchor point for tow strap or winch cable. Severe personal injury or death could result.

- 2) Observe winch manufacturer's recommendations, cautions and warnings.
- 3) Attach return cable to tow hook or recovery eye when using a snatch block (See figure 1).

**CAUTION:** Do not attach return cable to winch mount. This may overload winch mount and/or front mounted receiver.

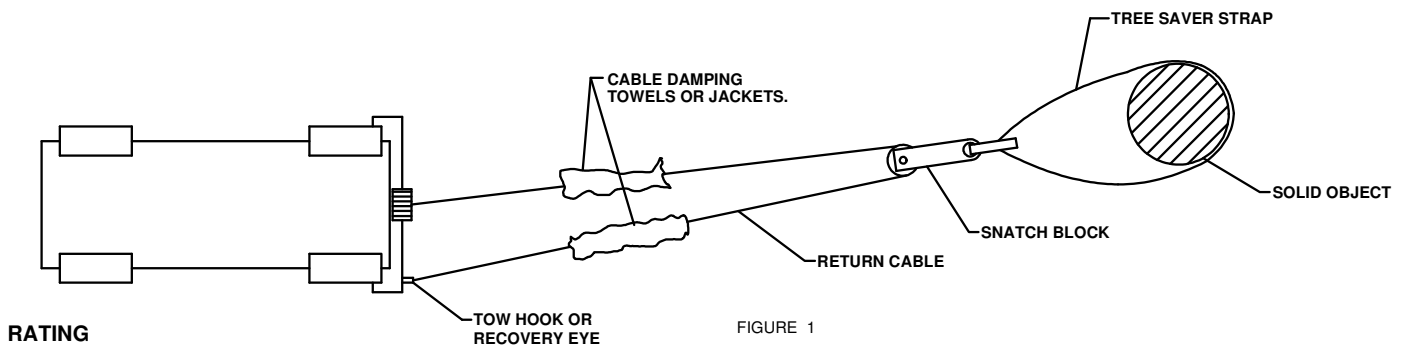

## RATING

For **Maximum** line pull rating, winch cable must not exceed:  
- 15 degree angle up or down from horizontal (See Figure 2).  
- 45 degree angle left or right from straight ahead (See Figure 3).

**CAUTION:** Exceeding the maximum line pull rating may over load winch, winch mount, and/or front mounted receiver.

