

GROSS LOAD CAPACITY WHEN USED AS A WEIGHT CARRYING HITCH: 5,000 LBS. TRAILER WEIGHT & 500 LBS. TONGUE WEIGHT.
 GROSS LOAD CAPACITY WHEN USED AS A STRAIGHT LINE PULL: 9,000 LBS. MAX. LINE PULL.
***** DO NOT EXCEED VEHICLE MANUFACTURER'S RECOMMENDED TOWING CAPACITY. *****
 HAVING INSTALLATION QUESTIONS? CALL TECHNICAL SUPPORT AT 1-800-798-0813

Parts List			
ITEM	QTY	PART NUMBER	DESCRIPTION
1	4	1/2-13 x 1 3/4	CARRIAGE BOLT
2	4	CM-SP6	.250 x 1.00 x 3.00 SQ. HOLE SPACER
3	4	HFN 1213	HEX FLANGE NUT
4	2	1_2 FISHWIRE	1/2" FISHWIRE

TOOLS REQUIRED
 3/4" SOCKET
 RATCHET
 TORQUE WRENCH
 ROTARY CUTTING TOOL

FISHWIRE TECHNIQUE
 INSERT COILED END OF FISHWIRE TOOL THROUGH HITCH MOUNTING HOLE IN VEHICLE FRAME RAIL AND OUT THE ACCESS HOLE. PASS COILED END OF FISHWIRE THROUGH SPACER AND THREAD BOLT INTO COIL. KINK WIRE TO KEEP SPACER SEPERATE FROM BOLT AS SHOWN. PULL FISHWIRE, SPACER, AND BOLT THROUGH FRAME AND OUT MOUNTING HOLE. USE FISHWIRE TO GUIDE HITCH DURING MOUNTING AND PREVENT LOSS OF BOLT / SPACER INSIDE FRAME RAIL.
***NOTE: SOME VEHICLES MAY FISHWIRE THROUGH END OF FRAME**

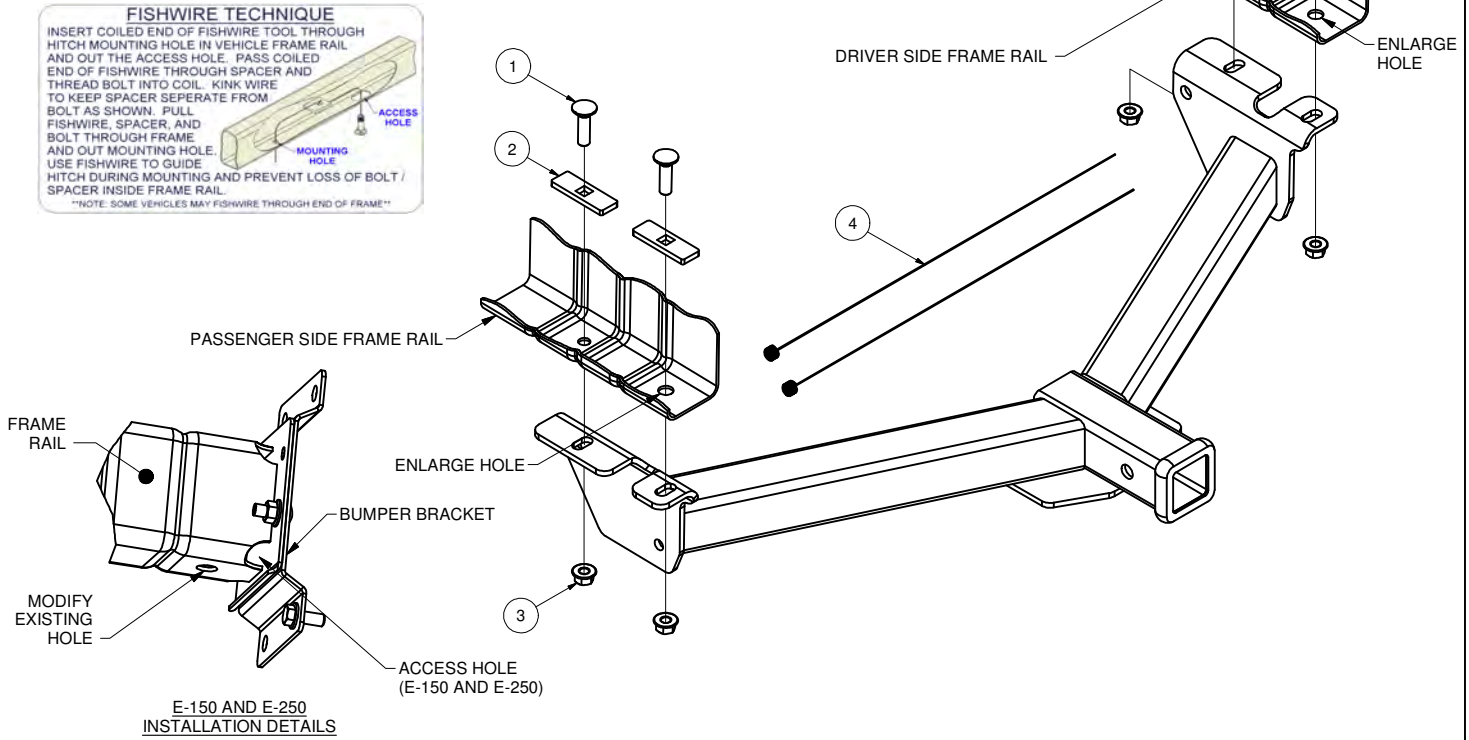
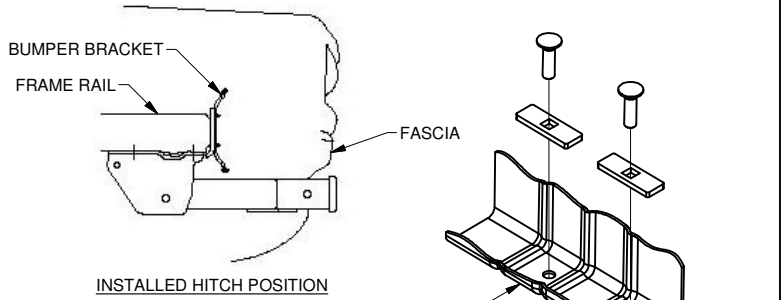

E-150 AND E-250 INSTALLATION DETAILS

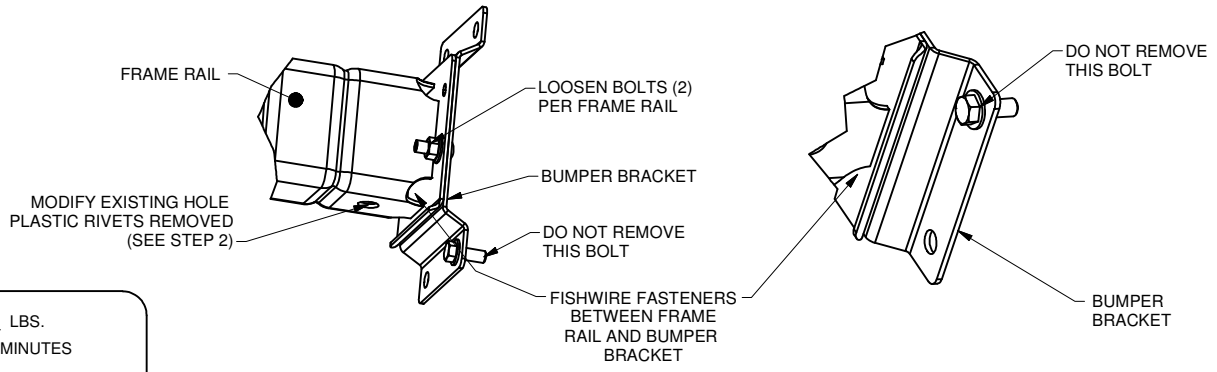

E-350 INSTALLATION DETAILS

HITCH WEIGHT: 32 LBS.
 INSTALL TIME: 30 MINUTES
 INSTALL NOTES:
 - DRILLING REQUIRED
 - FISHWIRE HARDWARE
 - FASCIA TRIM REQUIRED

PERIODICALLY CHECK THIS RECEIVER HITCH TO ENSURE THAT ALL FASTENERS ARE TIGHT AND THAT ALL STRUCTURAL COMPONENTS ARE SOUND.

Curt Manufacturing Inc., warrants this product to be free of defects in material and/or workmanship at the time of retail purchase by the original purchaser. If the product is found to be defective, Curt Manufacturing Inc., may repair or replace the product, at their option, when the product is returned, prepaid, with proof of purchase. Alteration to, misuse of, or improper installation of this product voids the warranty. Curt Manufacturing Inc.'s liability is limited to repair or replacement of products found to be defective, and specifically excludes liability for incidental or consequential loss or damage.

***** DO NOT EXCEED VEHICLE MANUFACTURER'S RECOMMENDED TOWING CAPACITY. *****
 HAVING INSTALLATION QUESTIONS? CALL TECHNICAL SUPPORT AT 1-800-798-0813

INSTALLATION STEPS:

1. Remove the under body panel by removing the (4) bolts securing the under body panel.
(See under body panel detail.)
2. If present (E-350) remove any plastic rivets from the forward attachment on the vehicle. Fold the plastic between plastic covering and the frame rail.
3. Enlarge the forward hole on the vehicle with a 17/32" drill bit.
4. Trim the lower fascia as shown in the Lower Fascia Trim Detail.
 - a) Locate the center of the fascia from left to right and mark 1-1/2" to each side.
 - b) Mark 3" down from the existing opening to create a 3" square cut-out.
 - c) Drill (2) 3/8" holes in the corners.
 - d) Carefully remove material to create a 3" hole for the receiver tube.
5. E-150 and 250: Feed 1/2" carriage bolts and spacers through the access holes at the forward end of the frame rails using a fishwire as shown. (See E-150 and E-250 Installation Details.)

 E-350: Loosen the bolts at the end of the frame rail and bumper bracket enough to feed the fasteners into the opening at the end of the frame rail. **Do not remove the bolts completely.** The bumper may shift downward slightly. After feeding the fasteners into the frame rail, raise the bumper and retighten the bolts. (See E-350 Installation Details.)
6. Raise the hitch into position over fishwired hardware and secure with (4) 1/2" hex flange nuts as shown.
7. Torque all 1/2" fasteners to 110 ft-lbs.
8. Return the under body panel to the owner, or obtain permission to trim the under body panel as shown below in the under body panel detail.

Ford E-Series front bumper and fascia



Lower Fascia Trim Detail

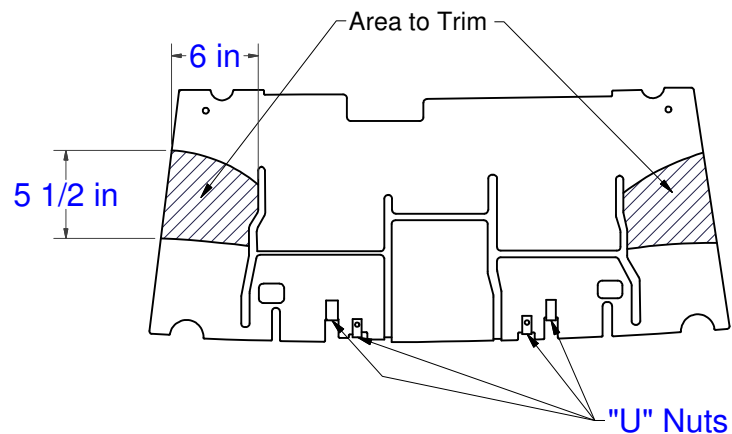

Under Body Panel Detail

PERIODICALLY CHECK THIS RECEIVER HITCH TO ENSURE THAT ALL FASTENERS ARE TIGHT AND THAT ALL STRUCTURAL COMPONENTS ARE SOUND.

Curt Manufacturing Inc., warrants this product to be free of defects in material and/or workmanship at the time of retail purchase by the original purchaser. If the product is found to be defective, Curt Manufacturing Inc., may repair or replace the product, at their option, when the product is returned, prepaid, with proof of purchase. Alteration to, misuse of, or improper installation of this product voids the warranty. Curt Manufacturing Inc.'s liability is limited to repair or replacement of products found to be defective, and specifically excludes liability for incidental or consequential loss or damage.

***** DO NOT EXCEED VEHICLE MANUFACTURER'S RECOMMENDED TOWING CAPACITY. *****
HAVING INSTALLATION QUESTIONS? CALL TECHNICAL SUPPORT AT 1-800-798-0813

FRONT MOUNTED ACCESSORIES

1. Do not exceed front axle Gross Weight Rating (GAWR). Consult owners manual or specification plate located on driver's door frame. Measure gross front axle weight by placing front wheels of loaded vehicle on a scale.

WARNING: Exceeding GAWR may overload the front axle and/or suspension. This could result in **accident, property damage and personal injury.**

2. Reposition front mounted license plate if obstructed.
3. Do not obstruct vehicle lights.
4. Allow free air flow into grille opening.
5. Rear wheel traction may be reduced. This could effect handling. Reduce speed and drive with caution.
6. Accessories extend front of vehicle. This may reduce approach angle. Use caution when parking and maneuvering.
7. Do not obstruct driver view.

VEHICLE RECOVERY AND WINCHING TIPS

1. Use OEM tow hooks, recovery eyes or a clevis mount for attachment of a tow strap or winch cable.

WARNING: NEVER use a ball and/or ball mount as an anchor point for tow strap or winch cable. Severe personal injury or death could result.

2. Observe winch manufacturer's recommendations, cautions and warnings.
3. Attach return cable to tow hook or recovery eye when using a snatch block (See Figure 1).

CAUTION: Do not attach return cable to winch mount. This may overload winch mount and/or front mounted receiver.

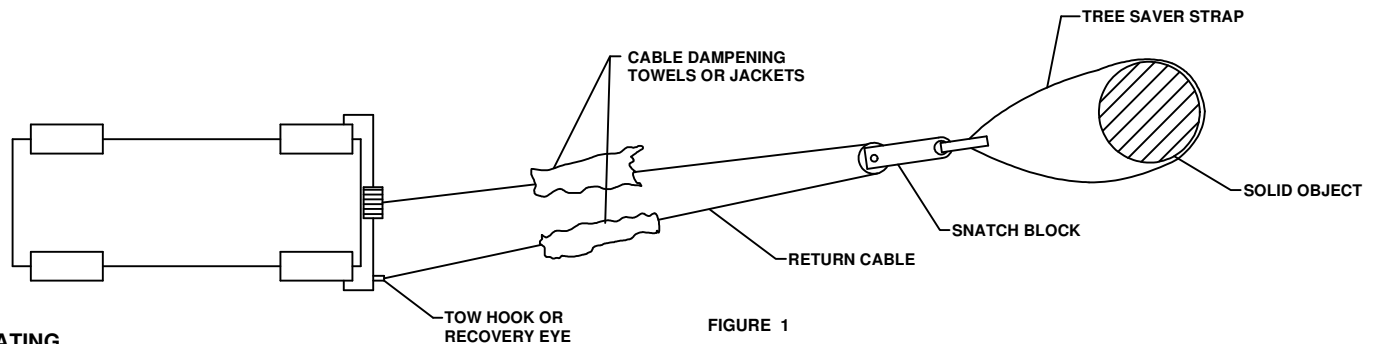

FIGURE 1

RATING

- For **Maximum** line pull rating, winch cable must not exceed:
- 15° angle up or down from horizontal (See Figure 2).
 - 45° angle left or right from straight ahead (See Figure 3).

CAUTION: Exceeding the maximum line pull rating may over load winch, winch mount, and/or front mounted receiver.

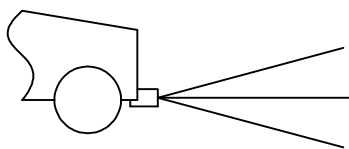

FIGURE 2

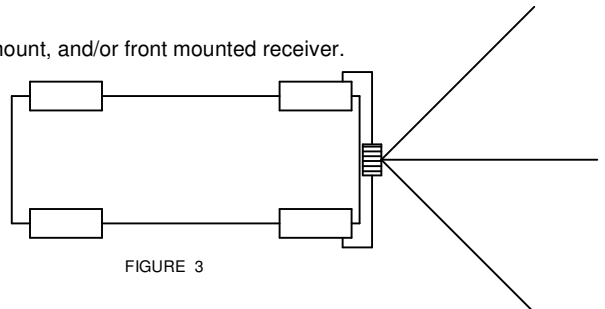

FIGURE 3