

31297 2004-09 DODGE DURANGO / 2006-09 CHRYSLER ASPEN

1/2/2013

GROSS LOAD CAPACITY WHEN USED AS A WEIGHT CARRYING HITCH: 5000 LBS. TRAILER WEIGHT & 500 LBS. TONGUE WEIGHT.

GROSS LOAD CAPACITY WHEN USED AS A STRAIGHT LINE PULL: 9,000 LBS. MAX. LINE PULL.

*** DO NOT EXCEED VEHICLE MANUFACTURER'S RECOMMENDED TOWING CAPACITY. ***

HAVING INSTALLATION QUESTIONS? CALL TECHNICAL SUPPORT AT 1-800-798-0813

Parts List			
ITEM	QTY	PART NUMBER	DESCRIPTION
1	4	1_2 - 13 x 6	CARRIAGE BOLT (FULL THREAD)
2	8	HFN 1213	HEX FLANGE NUT
3	2	CM-31297-SP	.375" INSTALLATION SPACER
4	4	CM-31297-SP1	.706 OD x .622 ID, SPACER

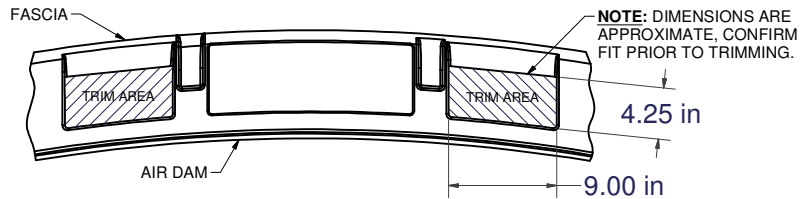

FASCIA TRIM DIAGRAM

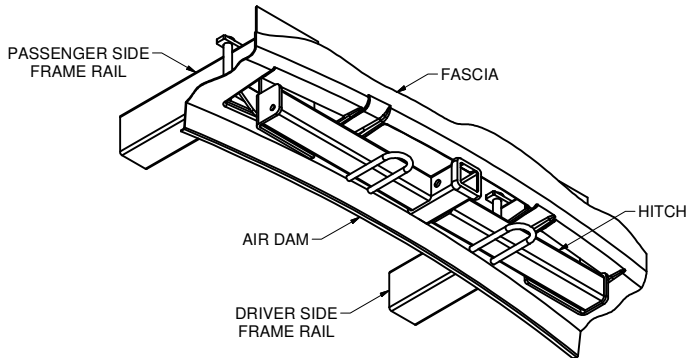

HITCH SHOWN IN PROPER POSITION

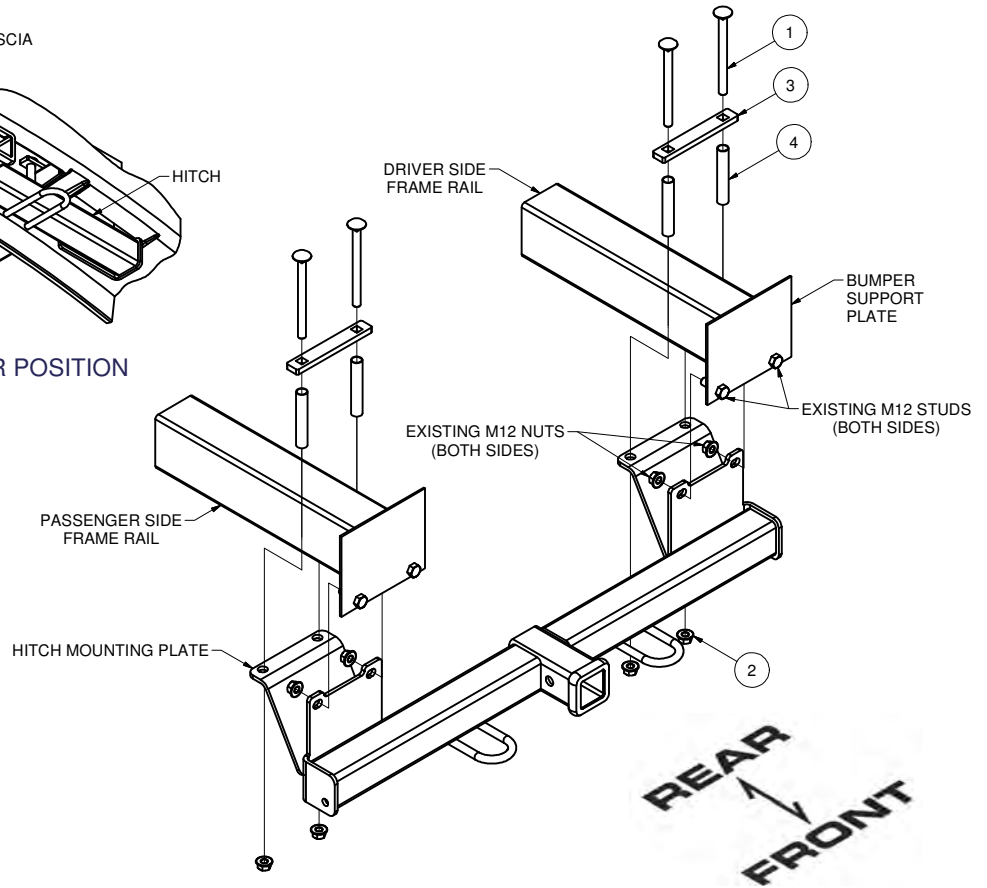

REAR
↑
FRONT

TOOLS REQUIRED

RATCHET
TORQUE WRENCH
18mm SOCKET
3/4" SOCKET

POSSIBLY REQUIRED

ROTARY CUTTING TOOL
MASKING TAPE
TAPE MEASURE

HITCH WEIGHT: 40 LBS.

INSTALL TIME

PROFESSIONAL: 30 MINUTES

NOVICE (DIY): 60 MINUTES

INSTALL NOTES:

- MAY REQUIRE FASCIA TRIMMING
- NO DRILLING REQUIRED

INSTALLATION STEPS

1. If no fascia cut-outs are present, mark and trim fascia panel. See Trim Diagram
Note: Trim dimensions are approximate, confirm fit prior to trimming.
2. Remove (4) lower M12 flange nuts from the front bumper studs, both sides.
3. Place carriage bolts into spacers provided and position them on top of vehicle frame rails.
4. Raise hitch into position over front bumper support studs and secure with existing flange nuts.
5. Place spacer tubes over the 1/2" carriage bolts bridging the span between the top of the frame rail and hitch mounting plate.
6. Install 1/2" flange nuts on carriage bolts and hand tighten.
7. Torque all 1/2" fasteners to 110 lb-ft.
Torque all M12 fasteners to 86 lb-ft.

PERIODICALLY CHECK THIS RECEIVER HITCH TO ENSURE THAT ALL FASTENERS ARE TIGHT AND THAT ALL STRUCTURAL COMPONENTS ARE SOUND.

Curt Manufacturing LLC., warrants this product to be free of defects in material and/or workmanship at the time of retail purchase by the original purchaser. If the product is found to be defective, Curt Manufacturing LLC., may repair or replace the product, at their option, when the product is returned, prepaid, with proof of purchase. Alteration to, misuse of, or improper installation of this product voids the warranty. Curt Manufacturing LLC.'s liability is limited to repair or replacement of products found to be defective, and specifically excludes liability for incidental or consequential loss or damage.

*****DO NOT EXCEED VEHICLE MANUFACTURER'S RECOMMENDED TOWING CAPACITY ***.**

FRONT MOUNTED ACCESSORIES

1) Do not exceed front axle Gross Weight Rating (GAWR). Consult owners manual or specification plate located on driver's door frame. Measure gross front axle weight by placing front wheels of loaded vehicle on a scale.

WARNING: Exceeding GAWR may overload the front axle and/or suspension. This could result in **accident, property damage and personal injury.**

- 2) Reposition front mounted license plate if obstructed.
- 3) Do not obstruct vehicle lights.
- 4) Allow free air flow into grille opening.
- 5) Rear wheel traction may be reduced. This could effect handling. Reduce speed and drive with caution.
- 6) Accessories extend front of vehicle. This may reduce approach angle. Use caution when parking and maneuvering.
- 7) Do not obstruct driver view.

VEHICLE RECOVERY AND WINCHING TIPS

1) Use OEM tow hooks, recovery eyes or a clevis mount for attachment of a tow strap or winch cable.

WARNING: NEVER use a ball and/or ball mount as an anchor point for tow strap or winch cable. Severe personal injury or death could result.

- 2) Observe winch manufacturer's recommendations, cautions and warnings.
- 3) Attach return cable to tow hook or recovery eye when using a snatch block (See figure 1).

CAUTION: Do not attach return cable to winch mount. This may overload winch mount and/or front mounted receiver.

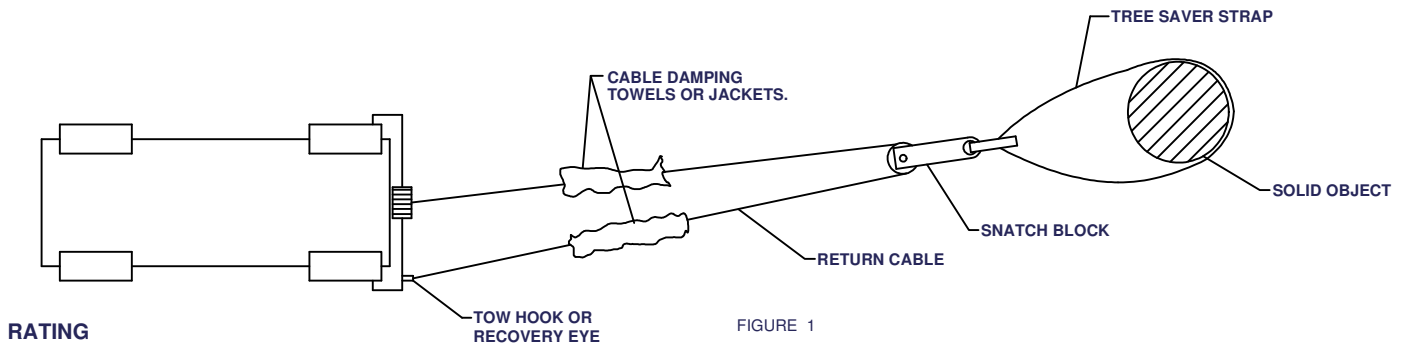

RATING

For **Maximum** line pull rating, winch cable must not exceed:

- 15 degree angle up or down from horizontal (See Figure 2).
- 45 degree angle left or right from straight ahead (See Figure 3).

CAUTION: Exceeding the maximum line pull rating may over load winch, winch mount, and/or front mounted receiver.

