

31320**DODGE RAM FRONT HITCH**

10/5/2012

GROSS LOAD CAPACITY WHEN USED AS A WEIGHT CARRYING HITCH: 5,000 LBS. TRAILER WEIGHT & 500 LBS. TONGUE WEIGHT.
 GROSS LOAD CAPACITY WHEN USED AS A STRAIGHT LINE PULL: 9,000 LBS. MAX. LINE PULL.
 *** DO NOT EXCEED VEHICLE MANUFACTURER'S RECOMMENDED TOWING CAPACITY. ***
 HAVING INSTALLATION QUESTIONS? CALL TECHNICAL SUPPORT AT 1-800-798-0813

Parts List			
ITEM	QTY	PART NUMBER	DESCRIPTION
1	6	7/16 - 14 x 1 3/4	CARRIAGE BOLT
2	6	7/16-14	LARGE HEX FLANGE NUT
3	6	CM-SP2	.250 x .88 x 2.25" SQUARE HOLE SPACER
4	1	CM-438-FW	7/16 " FISHWIRE TOOL

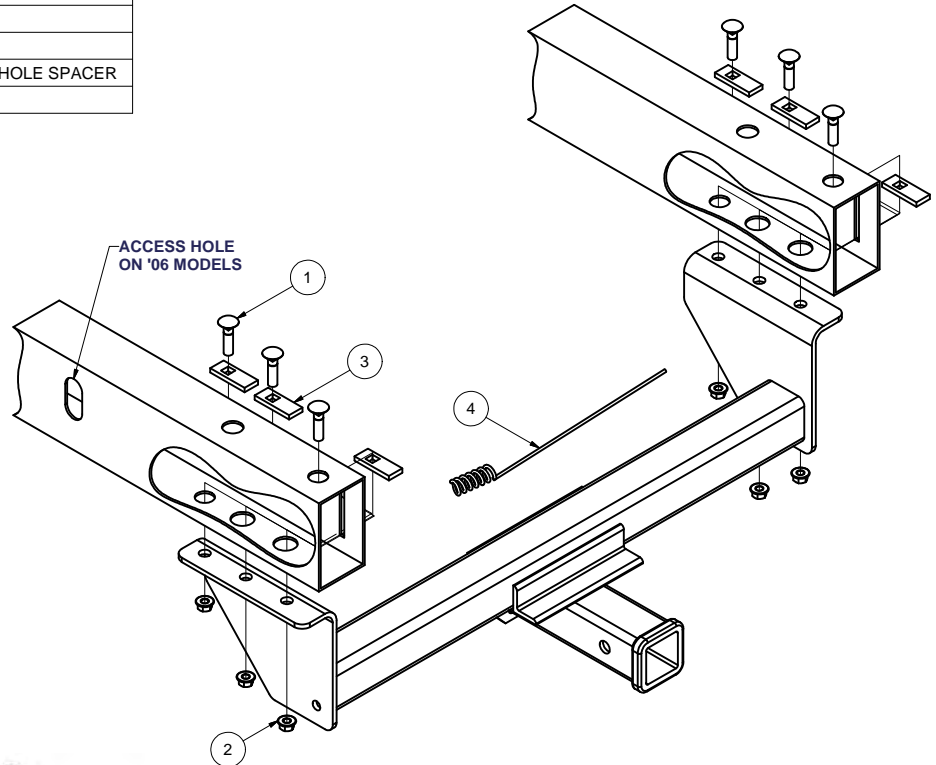
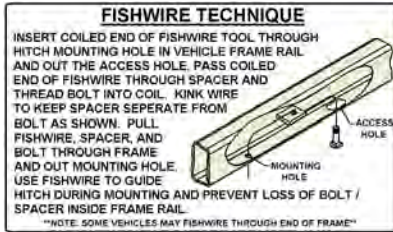

HITCH WEIGHT: 32 LBS.

INSTALL TIME

PROFESSIONAL: 30 MINUTES

NOVICE (DIY): 60 MINUTES

INSTALL NOTES:

- DRILLING REQUIRED
- '06 1/2 TON REQUIRES DRILLING AND FASCIA TRIMMING

INSTALLATION STEPS**NOTE:**

(For '06 models and later - The hitch must be used as a template for fascia trimming and to mark and drill holes as required.)

1. Insert the carriage bolt spacers through the frame access slot on the inside surface of the frame.
2. Use the fishwire provided to install the carriage bolts into the frame as shown. Be sure to pass the fishwire through the spacer previously installed before attaching it to the bolt. Install the rear bolt first, the center bolt second and the front bolt last. (both sides)
3. When all hardware is installed properly raise the hitch into position and attach a 7/16" flange nut to each bolt. (Trim front fascia as needed for hitch clearance.)
4. Torque all fasteners to 70 ft-lbs.

Note: If installing this hitch on a sport model you must use a 1" thick spacer block kit (31320-SK) or remove the metal reinforcement assembly and notch the front fascia.

PERIODICALLY CHECK THIS RECEIVER HITCH TO ENSURE THAT ALL FASTENERS ARE TIGHT AND THAT ALL STRUCTURAL COMPONENTS ARE SOUND.

*****DO NOT EXCEED VEHICLE MANUFACTURER'S RECOMMENDED TOWING CAPACITY ***.**

FRONT MOUNTED ACCESSORIES

1) Do not exceed front axle Gross Weight Rating (GAWR). Consult owners manual or specification plate located on driver's door frame. Measure gross front axle weight by placing front wheels of loaded vehicle on a scale.

WARNING: Exceeding GAWR may overload the front axle and/or suspension. This could result in **accident, property damage and personal injury.**

- 2) Reposition front mounted license plate if obstructed.
- 3) Do not obstruct vehicle lights.
- 4) Allow free air flow into grille opening.
- 5) Rear wheel traction may be reduced. This could effect handling. Reduce speed and drive with caution.
- 6) Accessories extend front of vehicle. This may reduce approach angle. Use caution when parking and maneuvering.
- 7) Do not obstruct driver view.

VEHICLE RECOVERY AND WINCHING TIPS

1) Use OEM tow hooks, recovery eyes or a clevis mount for attachment of a tow strap or winch cable.

WARNING: NEVER use a ball and/or ball mount as an anchor point for tow strap or winch cable. Severe personal injury or death could result.

- 2) Observe winch manufacturer's recommendations, cautions and warnings.
- 3) Attach return cable to tow hook or recovery eye when using a snatch block (See figure 1).

CAUTION: Do not attach return cable to winch mount. This may overload winch mount and/or front mounted receiver.

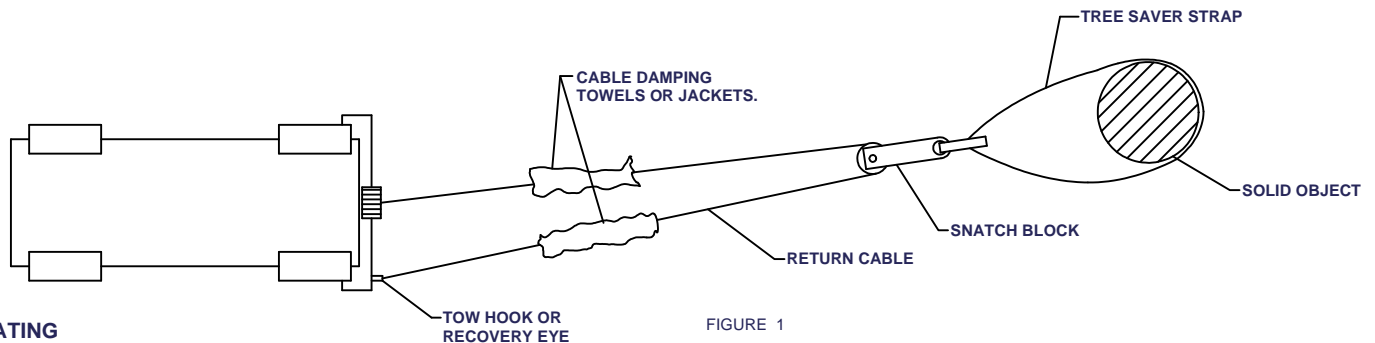

RATING

- For **Maximum** line pull rating, winch cable must not exceed:
- 15 degree angle up or down from horizontal (See Figure 2).
 - 45 degree angle left or right from straight ahead (See Figure 3).

CAUTION: Exceeding the maximum line pull rating may over load winch, winch mount, and/or front mounted receiver.

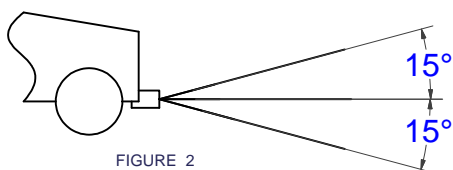

FIGURE 2

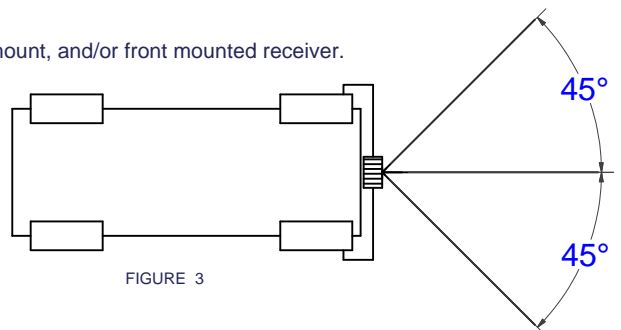

FIGURE 3