

31514
NISSAN XTERRA

GROSS LOAD CAPACITY WHEN USED AS A WEIGHT CARRYING HITCH: 3,500 LBS. TRAILER WEIGHT & 350 LBS. TONGUE WEIGHT.
GROSS LOAD CAPACITY WHEN USED AS STRAIGHT LINE PULL: 9,000 LBS. MAX. LINE PULL.

DO NOT EXCEED VEHICLE MANUFACTURER'S RECOMMENDED TOWING CAPACITY.***

Parts List				
ITEM	QTY	PART NUMBER	DESCRIPTION	
1	4	M12 - 1.25 x 40 HEX	HEX BOLT	
2	4	1/2"	CONICAL TOOTHED WASHER	
3	2	1/2-13 x 4	CARRIAGE BOLT	
4	2	CM-SP6	.250 x 1.00 x 3.00" SQUARE HOLE SPACER	
5	2	1/2 - 13	HEX FLANGE NUT	

TOOLS REQUIRED	
1/2" RATCHET	
TORQUE WRENCH	
6" EXTENSION	
19mm SOCKET	
17mm SOCKET	
10mm SOCKET	
3/8" RATCHET	

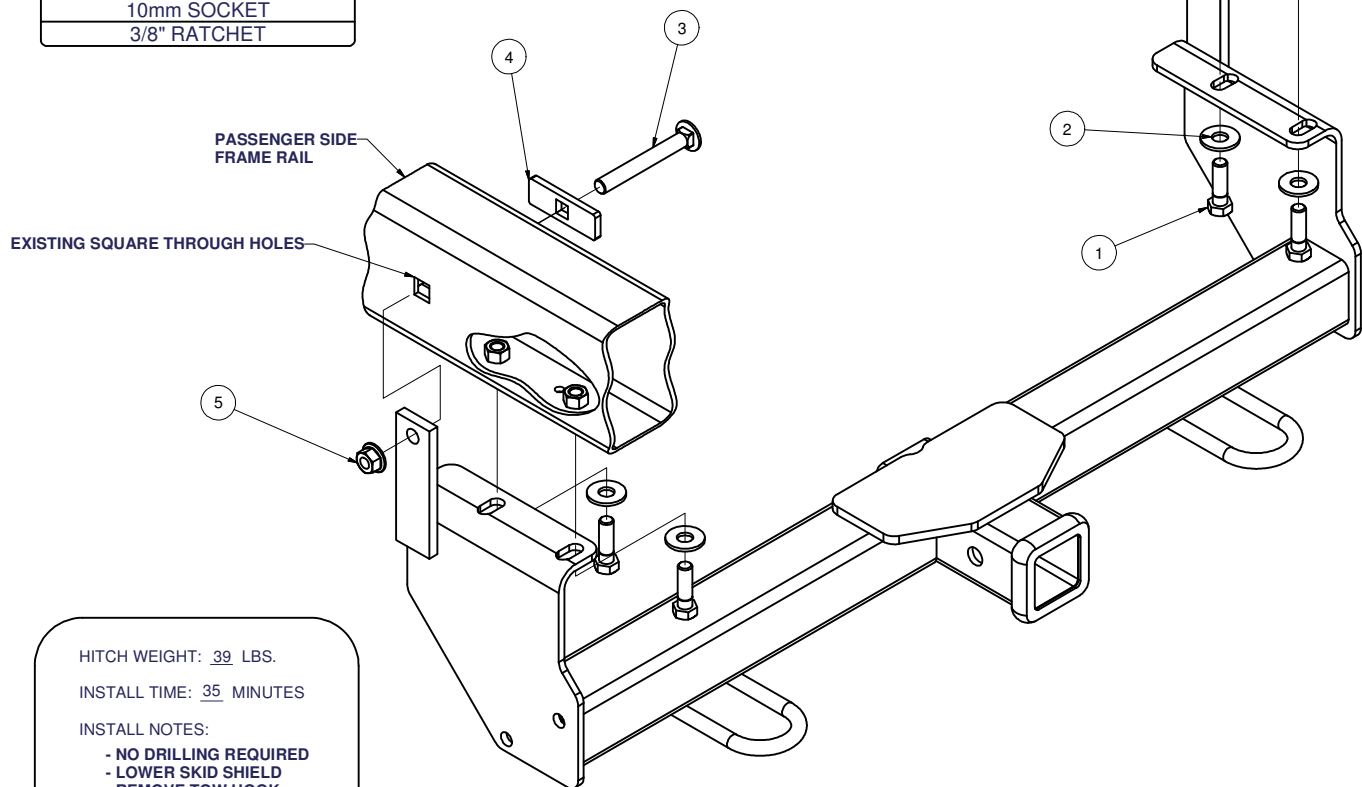
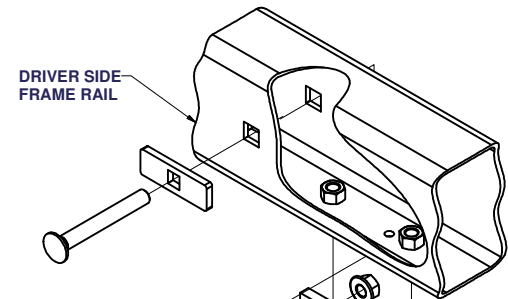

HITCH WEIGHT: 39 LBS.

INSTALL TIME: 35 MINUTES

INSTALL NOTES:

- NO DRILLING REQUIRED
- LOWER SKID SHIELD
- REMOVE TOW HOOK

INSTALLATION STEPS

- 1) Lower skid shield and remove tow hook. Return tow hook to customer.
- 2) Lift hitch into position and install (4) M12 fasteners with conical tooth washers.
- 3) Install 4" bolts with spacers into existing square holes in frame as shown.
(NOTE: may need to push coolant hose on driver side to allow for bolt installation.)
- 4) Torque all M12 fasteners to 86 lb-ft and all 1/2" fasteners to 110 lb-ft.
- 5) Re-install skid shield with original fasteners.

PERIODICALLY CHECK THIS RECEIVER HITCH TO INSURE THAT ALL FASTENERS ARE TIGHT AND THAT ALL STRUCTURAL COMPONENTS ARE SOUND.

31514

NISSAN XTERRA

DO NOT EXCEED VEHICLE MANUFACTURER'S RECOMMENDED TOWING CAPACITY.

FRONT MOUNTED ACCESSORIES

1) Do not exceed front axle Gross Weight Rating (GAWR). Consult owners manual or specification plate located on driver's door frame. Measure gross front axle weight by placing front wheels of loaded vehicle on a scale.

WARNING: Exceeding GAWR may overload the front axle and/or suspension. This could result in **accident, property damage and personal injury.**

- 2) Reposition front mounted license plate if obstructed.
- 3) Do not obstruct vehicle lights.
- 4) Allow free air flow into grille opening.
- 5) Rear wheel traction may be reduced. This could effect handling. Reduce speed and drive with caution.
- 6) Accessories extend front of vehicle. This may reduce approach angle. Use caution when parking and maneuvering.
- 7) Do not obstruct driver view.

VEHICLE RECOVERY AND WINCHING TIPS

1) Use OEM tow hooks, recovery eyes or a clevis mount for attachment of a tow strap or winch cable.

WARNING: NEVER use a ball and/or ball mount as an anchor point for tow strap or winch cable. Severe personal injury or death could result.

- 2) Observe winch manufacturer's recommendations, cautions and warnings.
- 3) Attach return cable to tow hook or recovery eye when using a snatch block (See figure 1).

CAUTION: Do not attach return cable to winch mount. This may overload winch mount and/or front mounted receiver.

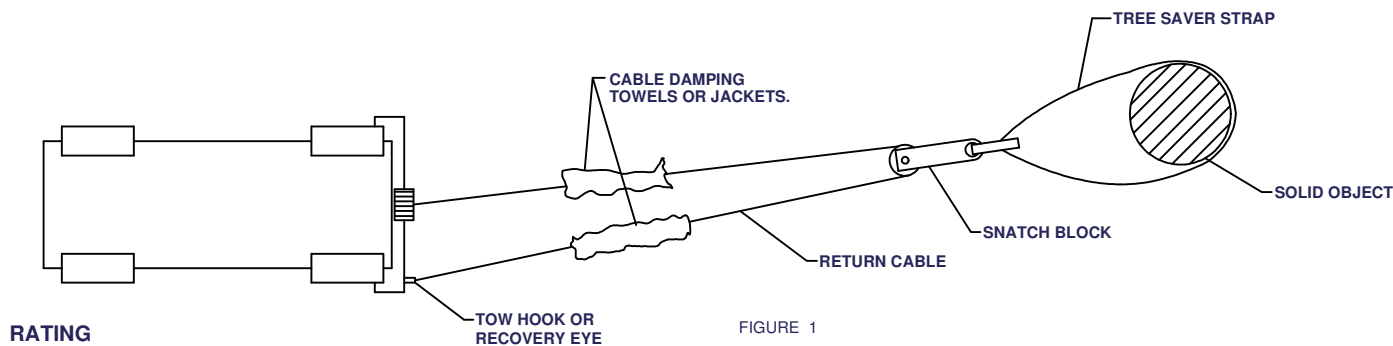

RATING

For **Maximum** line pull rating, winch cable must not exceed:

- 15 degree angle up or down from horizontal (See Figure 2).
- 45 degree angle left or right from straight ahead (See Figure 3).

CAUTION: Exceeding the maximum line pull rating may over load winch, winch mount, and/or front mounted receiver.

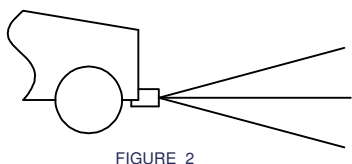

FIGURE 2

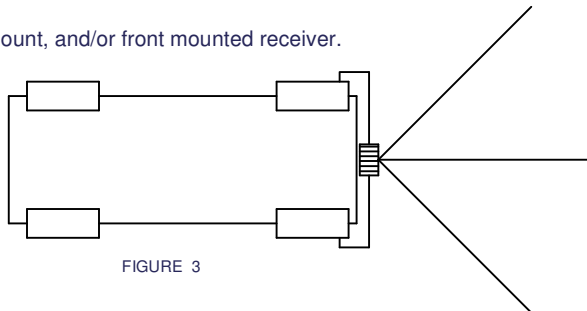

FIGURE 3