

60631

88-98 CHEVY & GMC 1/2, 3/4, & 1 TON TRUCKS
 99-00 CHEVY & GMC 3/4 & 1 TON HEAVY DUTY TRUCKS
****OLD BODY STYLE** (LONG & SHORT BED)**

WARNING!! BRAKE, FUEL, AND ELECTRICAL LINES MAY NEED TO BE LOOSENED OR REPOSITIONED TO PROVIDE CLEARANCE FOR NEW HARDWARE. ALL MODELS REQUIRE MODIFICATION OR REMOVAL OF HEAT SHIELDS. ON SHORT BED MODELS, CHECK FOR ADEQUATE TURNING CLEARANCE BETWEEN THE FRONT OF ALL TRAILERS AND THE TRUCK CAB.

WARNING!! ON TWO WHEEL DRIVE TRUCKS A CLEARANCE CHECK MUST BE PERFORMED WHEN TRUCK IS LOADED AND UNLOADED TO VERIFY THE INVERTED BALL WILL NOT INTERFERE WITH THE TOP OF THE DIFFERENTIAL

INSTALLATION STEPS

BEFORE INSTALLING

An overhead lifting device, such as chain falls, engine hoist, or cable come-a-long, can be used to lift the center section of the hitch in place. Lower a loop of rope or chain through the hole in the truck bed floor and attach it to the round hitch receiver tube in the center section. Use the lifting device to raise the center section until the round hitch receiver tube that protrudes from the center section fits in the hole in the truck bed floor. Maintaining upward pressure may facilitate fastening the cross-member to the center section, especially if the truck bed floor has been distorted downward from heavy use. If you use an overhead-lifting device, it should be disconnected before squaring the center section across the frame, installing the sideplates and torquing fasteners.

- 1) Lower and remove spare tire.
- 2) Mark the location for the hole in the truck bed. Measure from the tail gate end of the truck bed, by hooking a tape measure over the **back of the truck box** and marking the correct location. **(NOTE: DO NOT MEASURE FROM EDGE OF TAILGATE)** Next, mark the center between the wheel wells. This marks the center point for the drill hole. This hole location is critical for the correct installation of this hitch. Measure, mark, and saw carefully. This location will put the ball 4"-5" in front of the axle.

Short Bed Installation	44 1/16"
Long Bed Installation	48 7/8"

NOTE: If truck has a plastic bed liner, you may drill through both, but it is more difficult to accurately locate the midpoint between the wheel wells, and to keep the bed liner from moving while cutting the hole. Make a 4"(3 5/8" for C-630/C-640) hole at this location using a 4"(or 3 5/8") hole saw, or by making a 4"(or 3 5/8") circle and cutting it out with a saber saw equipped with a metal cutting blade.

- 3) Install the front cross arm by sliding it between the truck bed and truck frame on the passenger side. Swing the driver's side into place as shown in **FIGURE 1**, then push the cross arm towards the front of truck. **(NOTE: HOLES IN THE CROSS ARM MUST BE FACING THE BACK END OF THE TRUCK)**

FRONT OF TRUCK

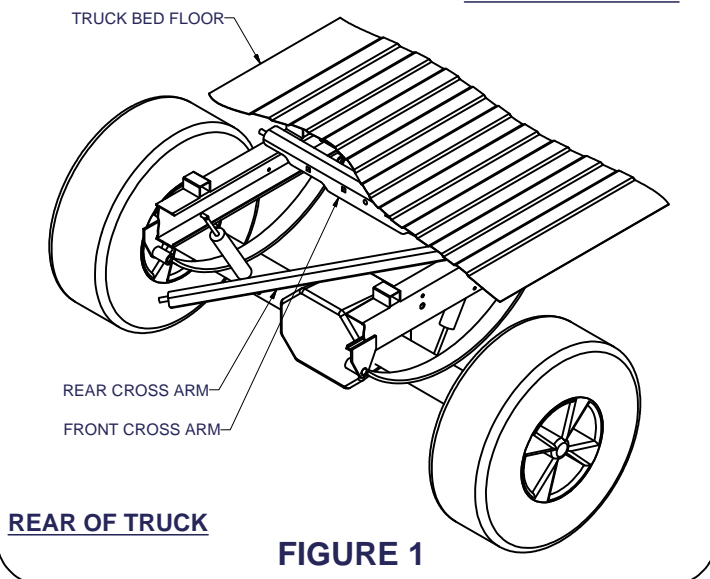

FRONT OF TRUCK

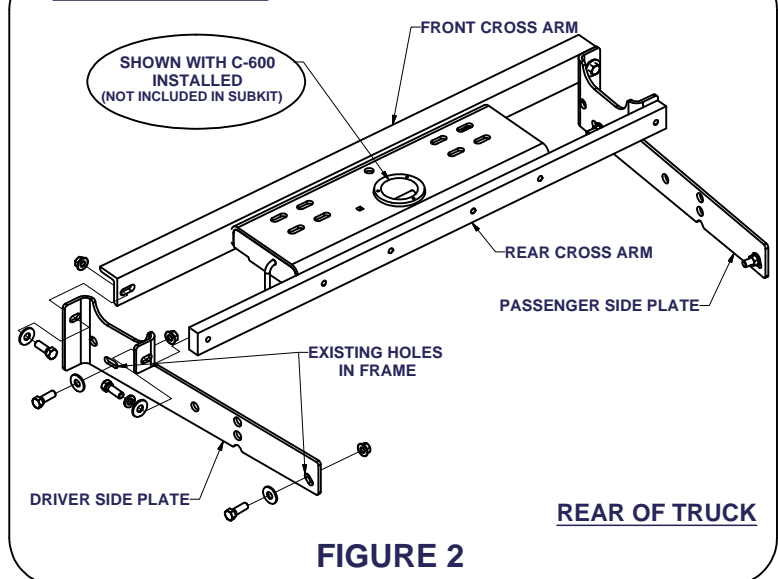

Curt Manufacturing Inc., warrants this product to be free of defects in material or workmanship at the time of retail purchase by the original purchaser. If the product is found to be defective, Curt Manufacturing Inc., may repair or replace the product, at their option, when the product is returned, prepaid, with proof of purchase. Alteration to, misuse of, or improper installation of this product voids the warrant. Curt Manufacturing Inc.'s liability is limited to repair or replacement of products found to be defective, and specifically excludes liability for incidental or consequential loss or damage.

****DO NOT EXCEED RECOMMENDED VEHICLE TOWING WEIGHT!****

60631

88-98 CHEVY & GMC 1/2, 3/4, & 1 TON TRUCKS
99-00 CHEVY & GMC 3/4 & 1 TON HEAVY DUTY TRUCKS
****OLD BODY STYLE** (LONG & SHORT BED)**

WARNING!! BRAKE, FUEL, AND ELECTRICAL LINES MAY NEED TO BE LOOSENED OR REPOSITIONED TO PROVIDE CLEARANCE FOR NEW HARDWARE. ALL MODELS REQUIRE MODIFICATION OR REMOVAL OF HEAT SHIELDS. ON SHORT BED MODELS, CHECK FOR ADEQUATE TURNING CLEARANCE BETWEEN THE FRONT OF ALL TRAILERS AND THE TRUCK CAB.

Installation Steps Continued

- 4) Install the rear cross arm by sliding it between the truck frame and truck bed above one of the rear tires. Slide through until both sides are resting on the truck frame. Rotate the cross arm up into the vertical position.
- 5) Raise the center section in position between the cross arms **with the ball cylinder towards the back of truck**. The round hitch receiver that protrudes from the top of the center section must fit through the hole in the truck bed. Using (4) 1/2" bolts, washers, and lock washers, attach the center section to the threaded holes in the rear cross arm. Next, attach the front cross arm (angle iron) to the center section using (4) 1/2" carriage bolts and flange nuts. **(Finger tight only.)**
- 6) Square the center section and cross arms across the frame. Thread a 1 1/2" bolt with a flat and lock washer through the back flange of the sideplate into the rear cross arm. Place a 1 1/2" bolt with a flat washer through the front flange of the sideplate into the front cross arm. (As shown in **Figure 2**) **Finger tight** with a 1/2" flange nut. **(REPEAT FOR OTHER SIDE)**
- 7) Align one front hole and one rear hole on each sideplate to the existing holes in the truck frame. Using a 1 1/2" bolt with a 1/2" flat washer attach the sideplates to the truck frame. (As shown in **Figure 2**) **Finger tight** with a 1/2" flange nut.
- 8) With the sideplates installed on both sides, torque all fasteners to 110 ft.-lbs. in the following order:
First: Torque the center section to the front and rear cross arms.
Second: Torque the sideplates to the truck frame on both sides.
Third: Torque the sideplate flanges to the front and rear cross arms.

Parts List			
ITEM	QTY	PART NUMBER	DESCRIPTION
1	10	HFN 1213	HEX FLANGE NUT
2	4	1/2-13 x 1 1/2	CARRIAGE BOLT
3	12	1/2 - 13 x 1 1/2	HEX BOLT
4	12	FW12	FW, 12, ZP
5	6	1/2"	LOCK WASHER

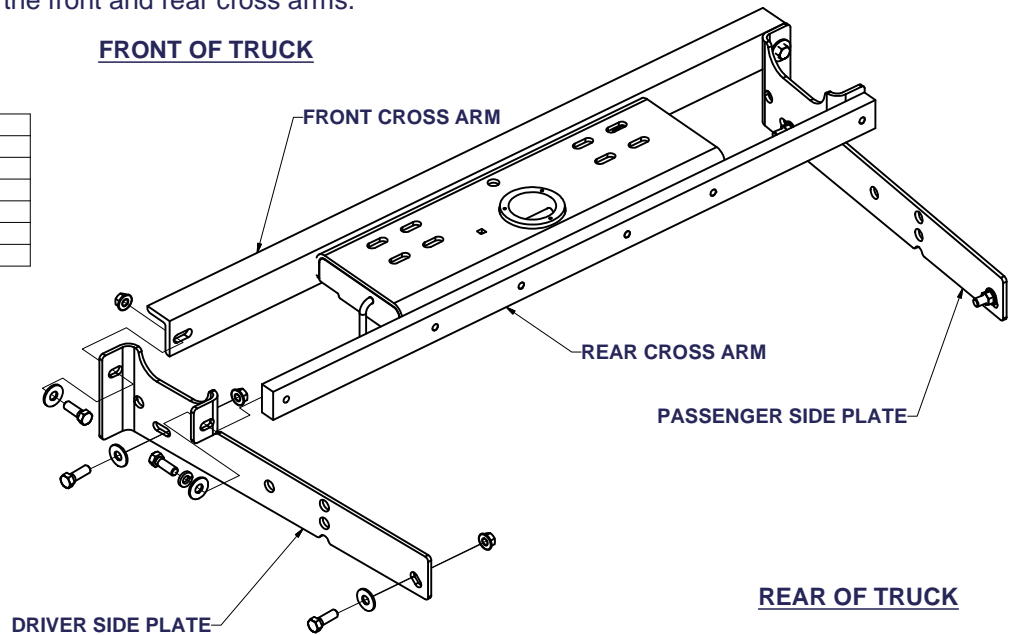

FIGURE 2

(REFER TO GOOSENECK HITCH INSTRUCTIONS FOR INSTALLATION AND OPERATING PROCEDURES)

Maintenance (Required every 30 days or prior to use)

1. Keep hitch ball lubricated regularly. Use silicone spray or equivalent to prevent wear and rust.
2. Keep hitch assembly free of dirt and other foreign debris.
3. Check for proper torque on all nuts and bolts before each use. Also check for excessive wear.
4. Check for ball wear before each use. **(Note: Do not tow trailer with worn or damaged parts.)**

Curt Manufacturing Inc., warrants this product to be free of defects in material or workmanship at the time of retail purchase by the original purchaser. If the product is found to be defective, Curt Manufacturing Inc., may repair or replace the product, at their option, when the product is returned, prepaid, with proof of purchase. Alteration to, misuse of, or improper installation of this product voids the warrant. Curt Manufacturing Inc.'s liability is limited to repair or replacement of products found to be defective, and specifically excludes liability for incidental or consequential loss or damage.

***DO NOT EXCEED VEHICLE MANUFACTURER'S RECOMMENDED TOWING

CAPACITY ***

CAB TO TRAILER CLEARANCE

REMOVAL OF REAR WINDOW ACCESSORIES MAY BE REQUIRED.

TRAILER

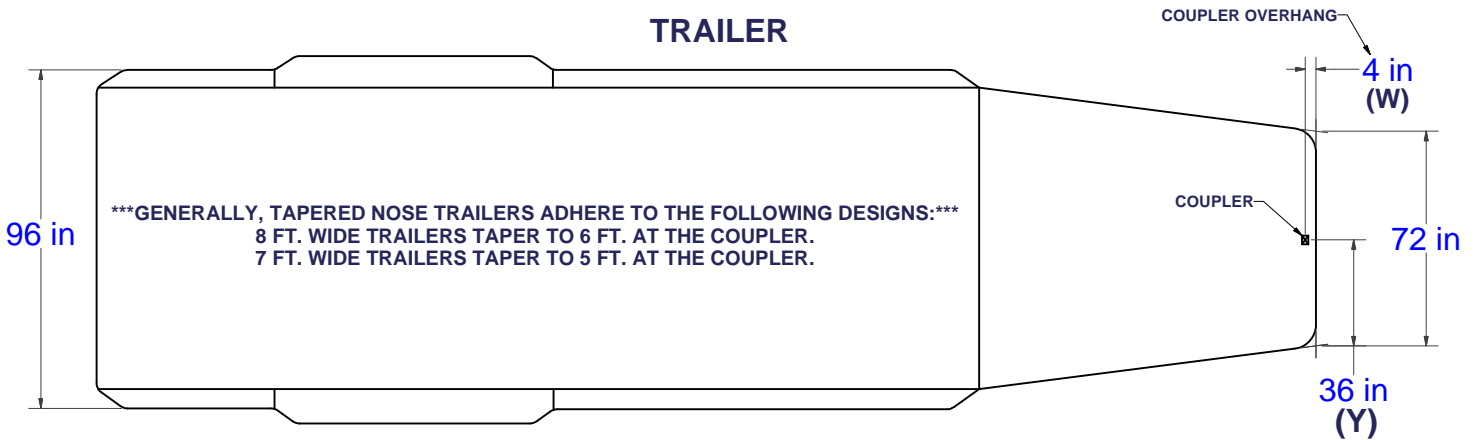

LONG & SHORT TRUCK BEDS

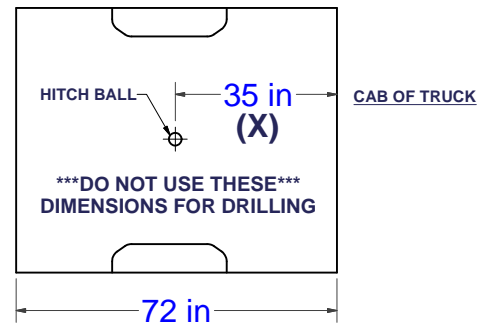
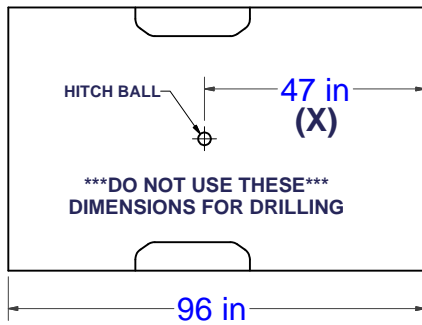

CLEARANCE CALCULATION

$$(CAB\ TO\ BALL\ CENTER) - \frac{1}{2} (TRAILER\ WIDTH) = (MINIMUM\ CLEARANCE)$$

$$(X) - (Y) = (Z)$$

IF THERE IS AN OVERHANG FROM THE COUPLER THEN THE EQUATION IS:

$$[(X) - (W)] - (Y) = (Z)$$

IF (Z) IS POSITIVE, TRAILER **WILL NOT** INTERFERE WITH CAB OF TRUCK.
 IF (Z) IS NEGATIVE, TRAILER **WILL** INTERFERE WITH CAB OF TRUCK!!!

EXAMPLE:

STANDARD TRAILER

$$X - Y = Z$$

$$35 - 36 = -1$$

(TRAILER **WILL INTERFERE** WITH CAB)

TRAILER WITH OVERHANG

$$[(X) - (W)] - Y = Z$$

$$[35 - 4] - 36 = -5$$

(TRAILER **WILL INTERFERE** WITH CAB)

YOUR CALCULATION:

(CAB TO BALL CENTER) _____

(COUPLER OVERHANG) - _____

1/2 (TRAILER WIDTH) - _____

(MINIMUM CLEARANCE) = _____

Curt Manufacturing Inc., warrants this product to be free of defects in material or workmanship at the time of retail purchase by the original purchaser. If the product is found to be defective, Curt Manufacturing Inc., may repair or replace the product, at their option, when the product is returned, prepaid, with proof of purchase. Alteration to, misuse of, or improper installation of this product voids the warrant. Curt Manufacturing Inc.'s liability is limited to repair or replacement of products found to be defective, and specifically excludes liability for incidental or consequential loss or damage.