



**Before returning this product
to the store of purchase**

Contact Dee Zee if you experience the following problems:

- Missing Parts
- Installation Problems/Questions
- Warranty Questions

1.800.779.2102

Hours of operation: 8am - 5pm CST, Mon-Friday

Review complete warranty policy and register your product at:

www.deezee.com



Dee Zee Running Board Installation Instructions

Congratulations on your purchase of a quality Dee Zee product. Dee Zee is recognized as having the highest quality running boards and accessories on the market today. We have earned this reputation by offering our customers a product they can be proud to place on their vehicles. Dee Zee meets all the criteria of manufacturing a custom-fit product which guarantees it to be the easiest product to install.

Note: Please take time to read all of the instructions before beginning this installation.

Warning! Please check for wiring or other obstructions before drilling any holes into the vehicle. If it is necessary to drill any holes into the vehicle, Dee Zee recommends putting a sealant or rust inhibitor around all holes drilled into the body of the vehicle.

Warning! It is the sole responsibility of the vehicle owner to check for tire clearance.

Warning! It is unlawful and dangerous to ride on running boards or side box boards while the vehicle is in motion.

Cleaning Instructions: To maintain the bright finish of your Dee Zee running boards, clean with a mild detergent. For our stainless steel products and accessories, the application of a high grade automotive type wax is recommended.

If you should happen to have any questions with this product or you have an installation question, please feel free to call us at:

1-800-779-8222











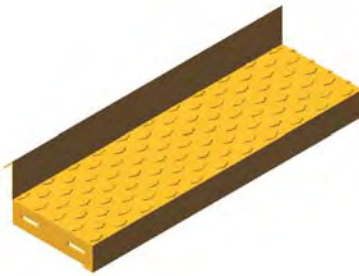









If you would like to find out more information on Dee Zee's products please feel free to visit our website at:

WWW.DEEZEE.COM

Dee Zee Britetread Running Board Installation Instruction

DZ 1358

(1999 - Current) Chevy 6' Box Pickup

<p>A Side Box Board</p>  <p>BD 1348L/R X2</p>	<p>B Bulb Seal Gasket</p>  <p>GSK-15 GSK-41 4.00 ft.</p>	<p>C Mudflaps</p>  <p>1 Left Side 1 Right Side</p>	
<p>D Left Mounting Bracket</p>  <p>B 1648LP X2</p>	<p>E Right Mounting Bracket</p>  <p>B 1648RP X2</p>	<p>F Support Bracket</p>  <p>PN 1382N X2</p>	<p>G 1/4 x 1" Ribneck Carriage Head Bolt</p>  <p>PN 87 X8</p>
<p>H 1/4" Flat Washer</p>  <p>PN 72 X16</p>	<p>I 1/4" Hex Nut</p>  <p>PN 71 X16</p>	<p>J 1/4 x 1" Sheet Metal Screw</p>  <p>PN 97B X4</p>	<p>K 1/4 x 3/4" Hex Head Bolt</p>  <p>PN 70 X4</p>
<p>L 3/8 x 1 1/4" Hex Head Bolt</p>  <p>PN 114B X2</p>	<p>M 3/8" Flat Washer</p>  <p>PN 113B X2</p>	<p>N 3/8" Threaded Plate</p>  <p>PN 407 X2</p>	<p>O 1/4 x 1 1/4" Hex Head Bolt</p>  <p>PN 78 X4</p>
<p>P 1/4" Fender Washer</p>  <p>PN 265 X4</p>	<p>Q 1/4 x 1" Hex Head Bolt</p>  <p>PN 96B X8</p>	<p>R 1/4" Flat Washer - Blk</p>  <p>PN 72B X16</p>	<p>S 1/4" Hex Nut - Blk</p>  <p>PN 71B X8</p>
<p>T 9" Angle Brace</p>  <p>B 865 X4</p>			

Tools Required:

Ratchet / Wrench 3/16" Drillbit

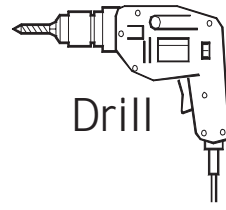

Drill

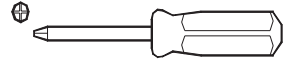

Phillips Head
Screwdriver

Sizes:

18mm

7/16"

3/8"

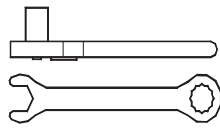

Tape Measure

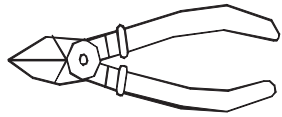
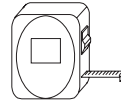

Tin-snips

1

Secure britetread mudflap (C) to britetread running board (A) using 1/4 x 3/4" hex head bolts (K), 1/4" flat washers (H), and 1/4" hex nuts (I). Tighten into place using a 7/16" wrench / or socket. Note: The mudflap will fit to the end of the board with the notch in it. Place bulb-seal gasket (B) onto the backlip of britetread running board (A) and trim flush with the britetread mudflap (D) and the end of britetread running board (A).

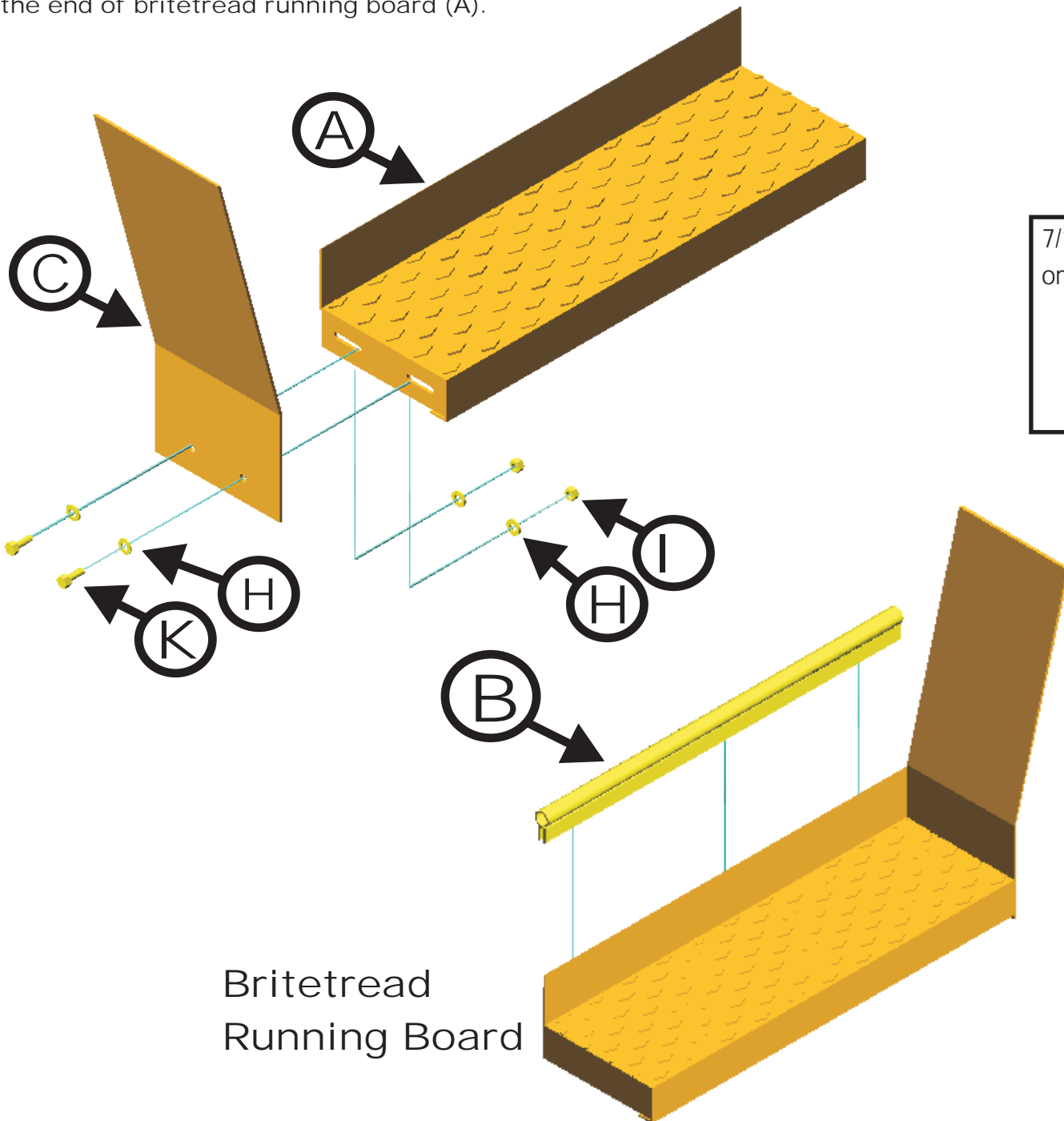

Britetread
Running Board

7/16" Wrench
or Socket

2 Bracket & Angle Assembly - Align the holes in the Angle (T) and Bracket (D) as shown. Insert the 1/4" X 1" Hex Head Bolt (Q) through the 1/4" Flat Washer (R) and through the Bracket (D) and Angle (T). Place a 1/4" Flat Washer (R) and 1/4" Hex Nut (S) onto the 1/4" x 1" Hex Head Bolt (Q) and tighten. (As shown below) Left Mounting Bracket Assembly shown. Right Mounting Bracket Assembly is mirror opposite.

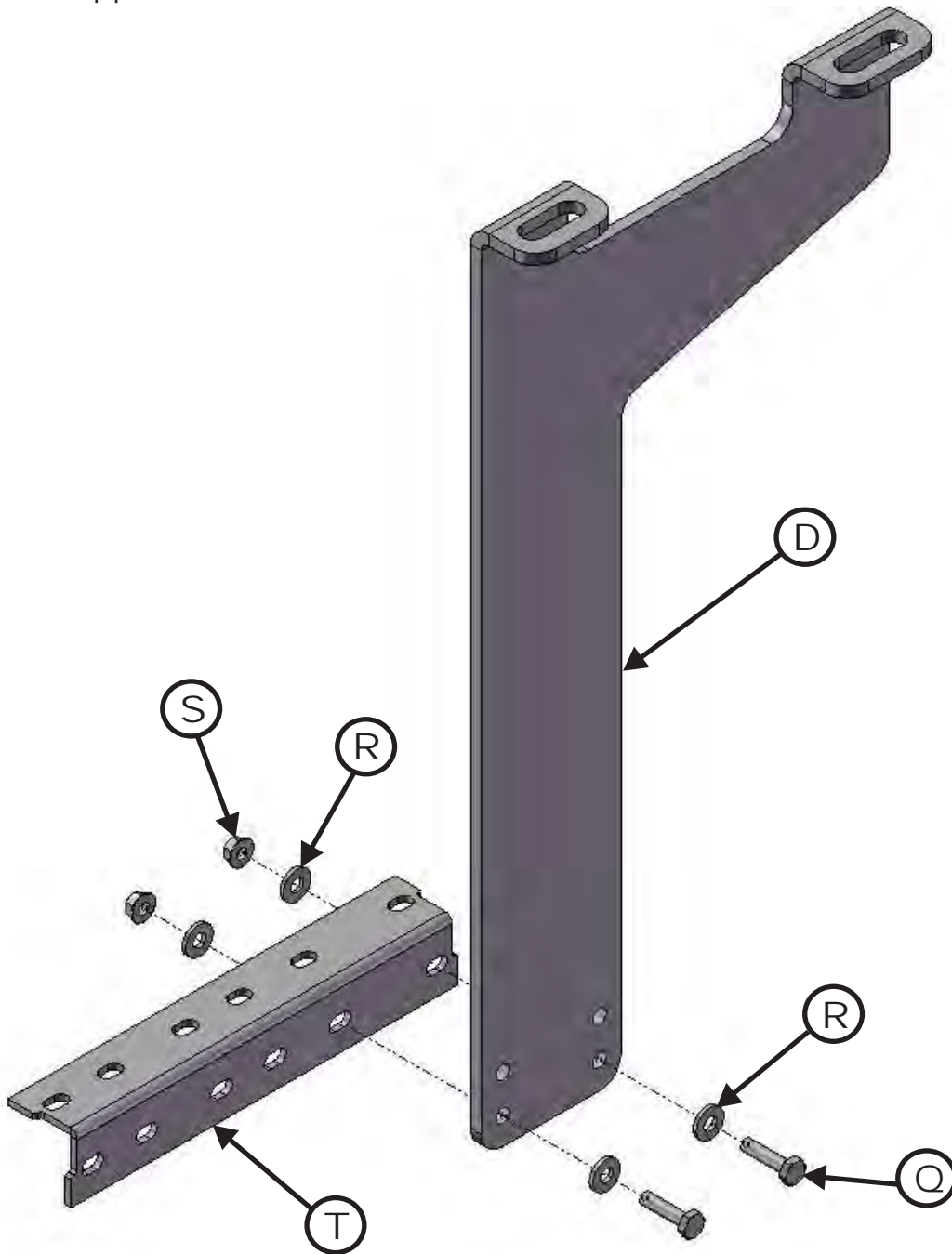

3 Old Body Style

Locate the front sub-box support as shown below. Remove the factory bolt holding the frame to the bottom of the sub-box support using an 18mm socket and ratchet.

Localice el apoyo de sub-caja de frente como mostrado abajo. Quite el cerrojo de la fábrica que tiene el marco al fondo del apoyo de sub-caja que utiliza un 18 Mm enchufe y trinquete.

18mm Wrench
or Socket

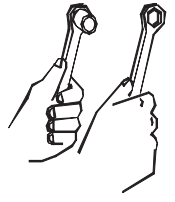

Front Sub-Box Support



Factory Bolt



Factory Bolt
Hole

4 Old Body Style

Place the support bracket (F) into the sub-box support (Step 1 and 2). Place the left mounting bracket (D) up to the sub-box support and replace the factory bolt (Step 3). Now secure the left mounting bracket (D) to the support bracket (F) using 1/4 x 1 1/4" hex head bolts (O) and 1/4" fender washers (P) (Step 4). Tighten the factory bolt using an 18mm socket and ratchet.

Tighten the 1/4 x 1 1/4" hex head bolt (O) using a 7/16" socket and ratchet.

Coloque el paréntesis de apoyo en el apoyo de sub-caja (Da un paso 1 y 2). Coloque la izquierda que monta paréntesis hasta el apoyo de sub-caja y reemplaza el cerrojo de la fábrica (Da un paso 3). Ahora asegure la izquierda que monta paréntesis al paréntesis del apoyo que utiliza 1/4 X 1 1/4" cerrojos de cabeza de mal de ojo (O) y 1/4" arandelas de guardabarros (P) (Da un paso 4). Apriete el cerrojo de la fábrica que utiliza un 18 Mm enchufe y trinquete. Apriete la 1/4 X 1 1/4" cerrojo de cabeza de mal de ojo (O) utilizando un 7/16" enchufe y trinquete.

18mm Wrench or Socket



7/16" Wrench or Socket

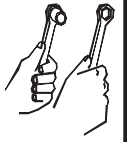

Step 1



Step 2



Step 3



Step 4



3 New Body Style

Locate the front sub-box support as shown below. Remove the factory bolt holding the frame to the bottom of the sub-box support using an 18mm socket and ratchet.

Localice el apoyo de sub-caja de frente como mostrado abajo. Quite el cerrojo de la fábrica que tiene el marco al fondo del apoyo de sub-caja que utiliza un 18 Mm enchufe y trinquete.

18mm Wrench
or Socket

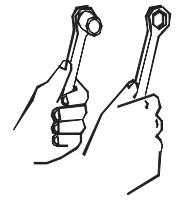

Front Sub-Box Support

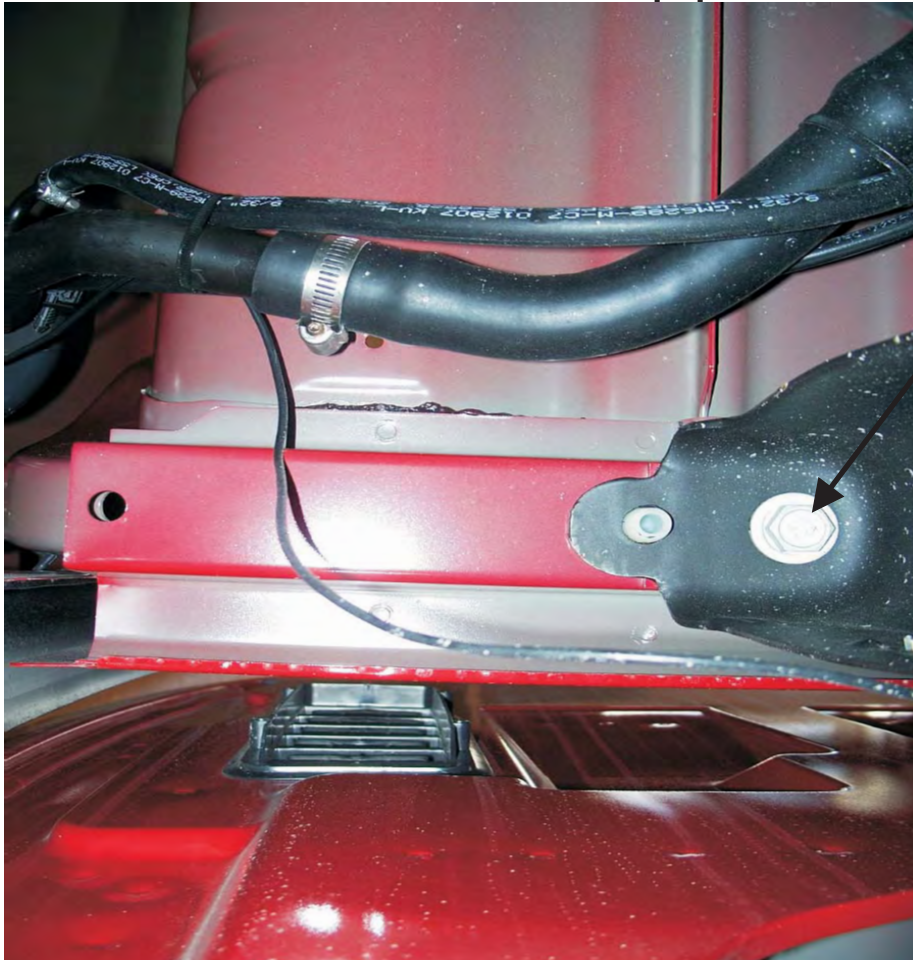

Factory Bolt

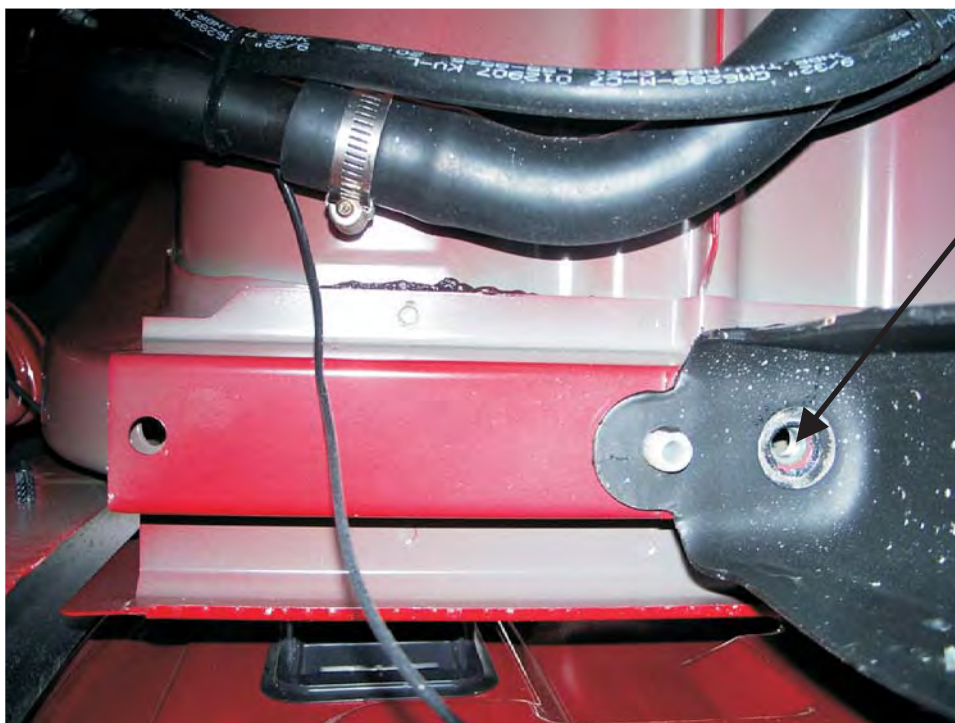

Factory Bolt
Hole

4 New Body Style

Place the 3/8" Threaded Plate (N) into the sub-box support (Step 1). Place the Left Mounting Bracket (D) up to the sub-box support and replace the factory bolt (Step 2). Now secure the Left Mounting bracket (D) to the sub-box support using 3/8 x 1 1/4" hex head bolt (L) and 3/8" flat washer (M) thru the 3/8" Threaded Plate (N) (Step 3). Tighten the factory bolt using an 18mm socket and ratchet. Tighten the 3/8 x 1 1/4" hex head bolt (L) using a 7/16" socket and ratchet.

18mm Wrench or Socket

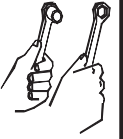

7/16" Wrench or Socket

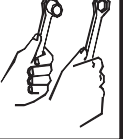

Coloque el 3/8" Plato Enhebrado (N) en el apoyo de sub-caja (Da un paso 1). Coloque la Izquierda que Monta Paréntesis (D) hasta el apoyo de sub-caja y reemplaza el cerrojo de la fábrica (Da un paso 2). Ahora asegure el derecho que monta paréntesis al apoyo de la sub-caja que utiliza 3/8 X 1 1/4" cerrojo de cabeza de mal de ojo (L) y 3/8" arandela plana (M) thru el 3/8" Plato Enhebrado (N) (Da un paso 3). Apriete el cerrojo de la fábrica que utiliza un 18 Mm enchufe y trinquete. Apriete la 3/8 X 1 1/4" cerrojo de cabeza de mal de ojo (L) utilizando un 7/16" enchufe y trinquete.

Step 1



Threaded Plate (N)

Step 2



Step 3



5 Old Body Style

Locate the rear sub-box support as shown below. Remove the factory bolt holding the frame to the bottom of the sub-box support using an 18mm socket and ratchet.

Localice el apoyo de sub-caja de trasero como mostrado abajo. Quite el cerrojo de la fábrica que tiene el marco al fondo del apoyo de sub-caja que utiliza un 18 Mm enchufe y trinquete.

18mm Wrench
or Socket

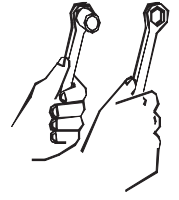

Rear Sub-Box Support



Factory Bolt



Factory Bolt
Hole

6 Old Body Style

Place the Left Mounting Bracket (D) up to the sub-box support. Replace the factory bolt (Step 1). Now place a 3/8" Threaded Plate (N) up inside of the sub-box support (Step 2). Place a 3/8 x 1 1/4" Hex Head Bolt (L) and 3/8" Flat Washer (M) up through the Left Mounting Bracket (D) and into the 3/8" Threaded Plate (N) (Step 3 and 4). Tighten the factory bolt using an 18mm socket and ratchet. Tighten the 3/8 x 1 1/4" Hex Head Bolt (L) using a 9/16" socket and ratchet.

18mm Wrench
or Socket

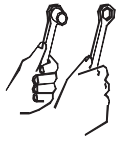

Coloque la Izquierda que Monta Paréntesis (D) hasta el apoyo de sub-caja. Reemplace el cerrojo de la fábrica (Da un paso 1). Ahora coloque un 3/8" Plato Enhebrado (N) arriba dentro del apoyo de sub-caja (Da un paso 2). Coloque una 3/8 X 1 1/4" Cerrojo de Cabeza de Mal de ojo (L) y 3/8" Arandela Plana (M) arriba por la Izquierda que Monta Paréntesis (D) y en el 3/8" Plato Enhebrado (N) (Da un paso 3 y 4). Apriete el cerrojo de la fábrica que utiliza un 18 Mm enchufe y trinquete. Apriete la 3/8 X 1 1/4" Cerrojo de Cabeza de Mal de ojo (L) utilizando un 9/16" enchufe y trinquete.

9/16" Wrench
or Socket

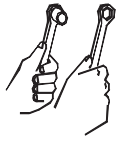

Step 1



Step 2



Step 3



5 New Body Style

Locate the rear sub-box support as shown below. Remove the factory bolt holding the frame to the bottom of the sub-box support using an 18mm socket and ratchet.

Localice el apoyo de sub-caja de trasero como mostrado abajo. Quite el cerrojo de la fábrica que tiene el marco al fondo del apoyo de sub-caja que utiliza un 18 Mm enchufe y trinquete.

18mm Wrench
or Socket

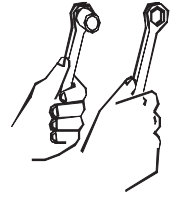

Rear Sub-Box Support



Factory Bolt

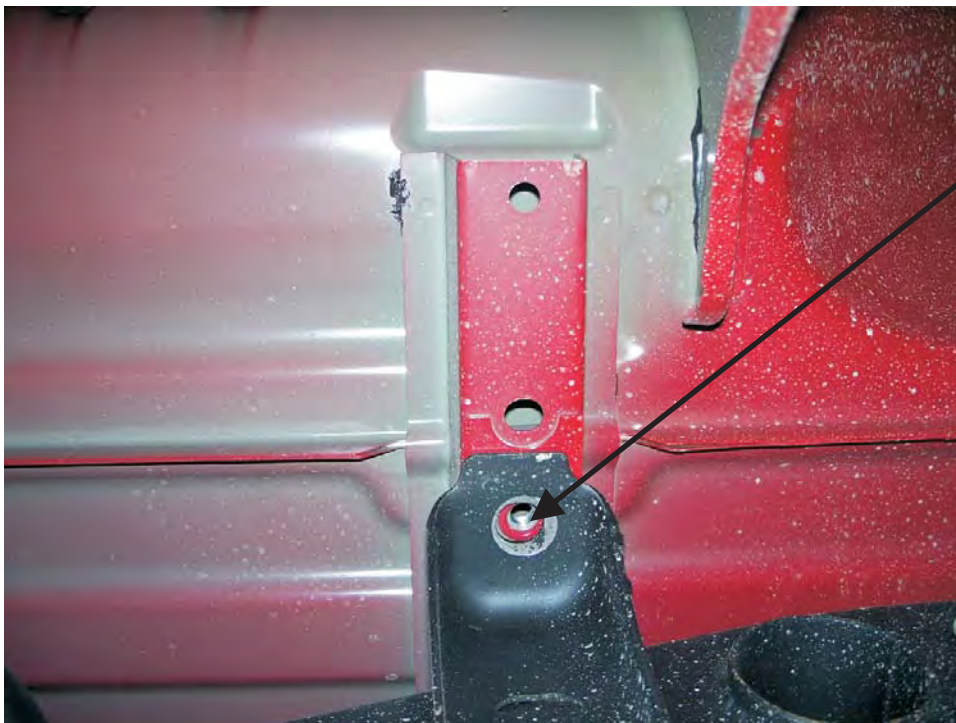

Factory Bolt
Hole

6 New Body Style

Place the Support Bracket (F) into the sub-box support (Step 1). Place 1/4" X 1 1/4" Hex Head Bolt (O) thru 1/4" Fender Washer (P) and thread thru the Support Bracket (F) and sub-box support (Step 2). Place the Right Mounting Bracket (E) up to the sub-box support and replace the factory bolt (Step 3). Now secure the Right Mounting Bracket (E) to the Support Bracket (F) using 1/4" X 1 1/4" Hex Head Bolt (O) and 1/4" Fender Washer (P) (Step 4).

18mm Wrench
or Socket

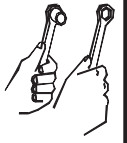

9/16" Wrench
or Socket



Coloque el Paréntesis de Apoyo (F) en el apoyo de sub-caja (Da un paso 1). El lugar 1/4" X 1 1/4" Cerrojo de Cabeza de Mal de ojo (O) thru 1/4" Arandela de Guardabarros (P) y thru de hilo el Paréntesis de Apoyo (F) y apoyo de sub-caja (Da un paso 2). Coloque el Derecho que Monta Paréntesis (E) hasta el apoyo de sub-caja y reemplaza el cerrojo de la fábrica (Da un paso 3). Ahora asegure el Derecho que Monta Paréntesis (E) al Paréntesis del Apoyo (F) utilizando 1/4" X 1 1/4" Cerrojo de Cabeza de Mal de ojo (O) y 1/4" Arandela de Guardabarros (P) (Da un paso 4).

Step 1

F



Step 2

F



Step 3

Right Mounting Bracket

Existing Bolt



Step 4

O P

O P



Place the side box board up to the mounting brackets. Make any final adjustments to the alignment of the running board on the vehicle and then use the existing slots in the mounting brackets to drill 1/4" holes through the side box board. Secure into place using 1/4 x 1" ribneck carriage head bolts (G), 1/4" flat washers (H), and 1/4" flat washers (I). Tighten into place using a 7/16" wrench / or socket. Note: You may need to tilt the board to get it into the correct position.

Coloque la tabla de caja de lado hasta los paréntesis que montan. Haga algún ajuste final a la alineación de la tabla corriente en el vehículo y entonces utilice las ranuras existentes en los paréntesis que montan para taladrar 1/4" hoyos por la tabla de caja de lado. Asegure en utilizar de lugar 1/4 X 1" cerrojos de cabeza de coche de ribneck (G), 1/4" arandelas planas (H), y 1/4" arandelas planas (yo). Apriete en el lugar que utiliza una 7/16" llave inglesa/o el enchufe. La nota: Usted puede necesitar inclinar la tabla para obtenerlo en la posición correcta.

7/16" Wrench
or Socket

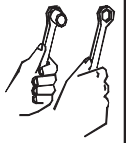

Drill with a
1/4" drillbit



Bent flange on Braces
should face each other.

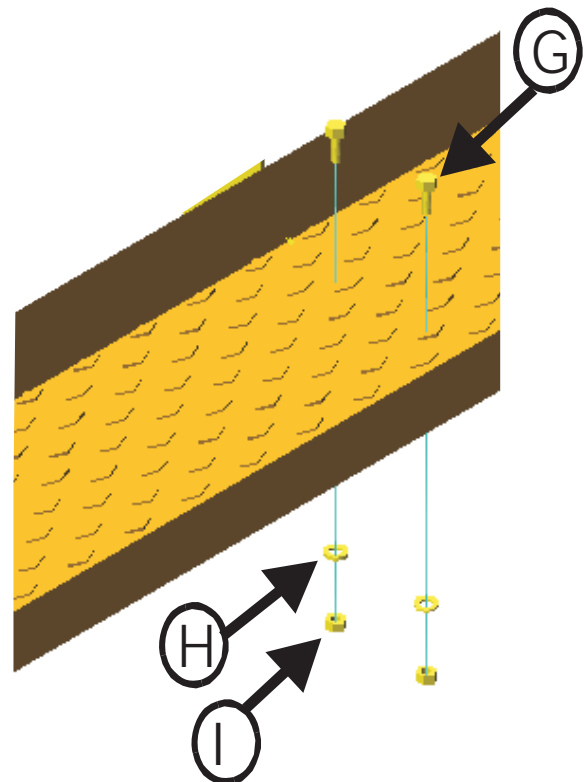
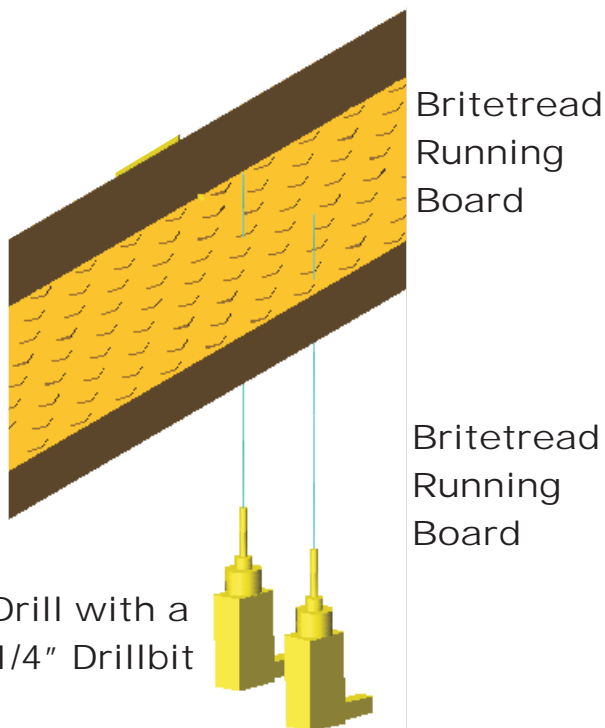

Drill two holes through the britetread mudflap and the sheet metal of the vehicle wheel well opening. Secure the britetread mudflap to the vehicle wheel well opening using 1/4 x 1" sheet metal screws (J). Tighten into place using a 3/8" wrench / or socket.

El taladro dos hoyos por el faldón de britetread y el metal laminado de la rueda de vehículo abriendo bien. Asegure el faldón de britetread a la rueda del vehículo abriendo bien utilizar 1/4 X 1" tornillos de metal laminado (J). Apriete en el lugar que utiliza una 3/8" llave inglesa/o el enchufe.

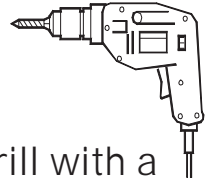

Drill with a
3/16" drillbit

3/8" Wrench
or Socket

