



**Before returning this product
to the store of purchase**

Contact Dee Zee if you experience the following problems:

- Missing Parts
- Installation Problems/Questions
- Warranty Questions

1.800.779.2102

Hours of operation: 8am - 5pm CST, Mon-Friday

Review complete warranty policy and register your product at:

www.deezee.com



Dee Zee Running Board Installation Instructions

Congratulations on your purchase of a quality Dee Zee product. Dee Zee is recognized as having the highest quality running boards and accessories on the market today. We have earned this reputation by offering our customers a product they can be proud to place on their vehicles. Dee Zee meets all the criteria of manufacturing a custom-fit product which guarantees it to be the easiest product to install.

Note: Please take time to read all of the instructions before beginning this installation.

Warning! Please check for wiring or other obstructions before drilling any holes into the vehicle. If it is necessary to drill any holes into the vehicle, Dee Zee recommends putting a sealant or rust inhibitor around all holes drilled into the body of the vehicle.

Warning! It is the sole responsibility of the vehicle owner to check for tire clearance.

Warning! It is unlawful and dangerous to ride on running boards or side box boards while vehicle is in motion.

Cleaning instructions: To maintain the finish of your Dee Zee running boards, clean with a mild detergent and use a high grade automotive type wax. **DO NOT USE ABRASIVE CLEANERS ON THIS PRODUCT!**

If you should happen to have any questions with this product or you have an installation question, please feel free to call us at:







1-800-779-8222

If you would like to find out more information on Dee Zee's products, please feel free to visit our website at:

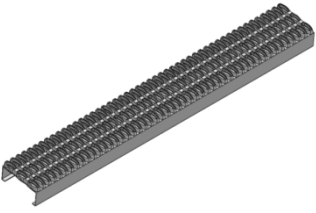
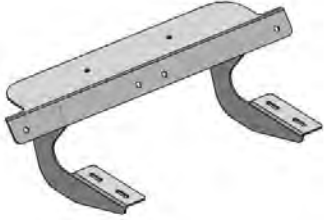
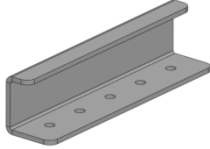
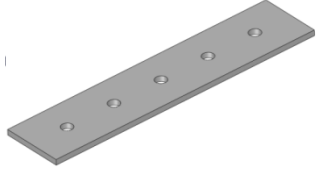
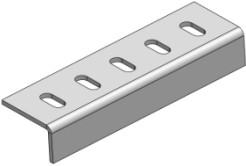
WWW.DEEZEE.COM

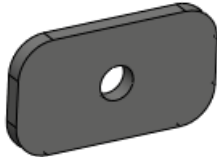
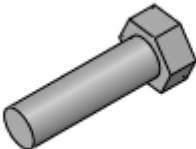
DZ 1534

Chevy Express Van Cab Length Running Boards (2009-current)

<p>A Running Boards</p>  <p>K2015P X2</p>	<p>B Mounting Bracket</p>  <p>B 1780P X2</p>	<p>C End Caps</p>  <p>EC RSP X4</p>	<p>D Strap Bracket</p>  <p>B 1791P X8</p>
<p>E Angle Bracket</p>  <p>B 1792P X4</p>	<p>F 1/4 washer</p>  <p>PN 72B X32</p>	<p>G 3/8 threaded plate</p>  <p>PN 407 X6</p>	<p>H 3/8 bolt</p>  <p>PN 114 X6</p>
<p>I 3/8 washer</p>  <p>PN 113 X6</p>	<p>J 1/4 sheet metal screw</p>  <p>PN 97 X4</p>	<p>K 1/4 bolt</p>  <p>PN 96B X16</p>	<p>L 1/4 nut</p>  <p>PN 71B X16</p>

Tools Required

Ratchet / Wrench
 3/16"
 7/16"
 3/8"

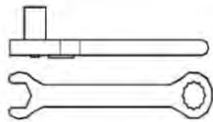

3/16" bit

1

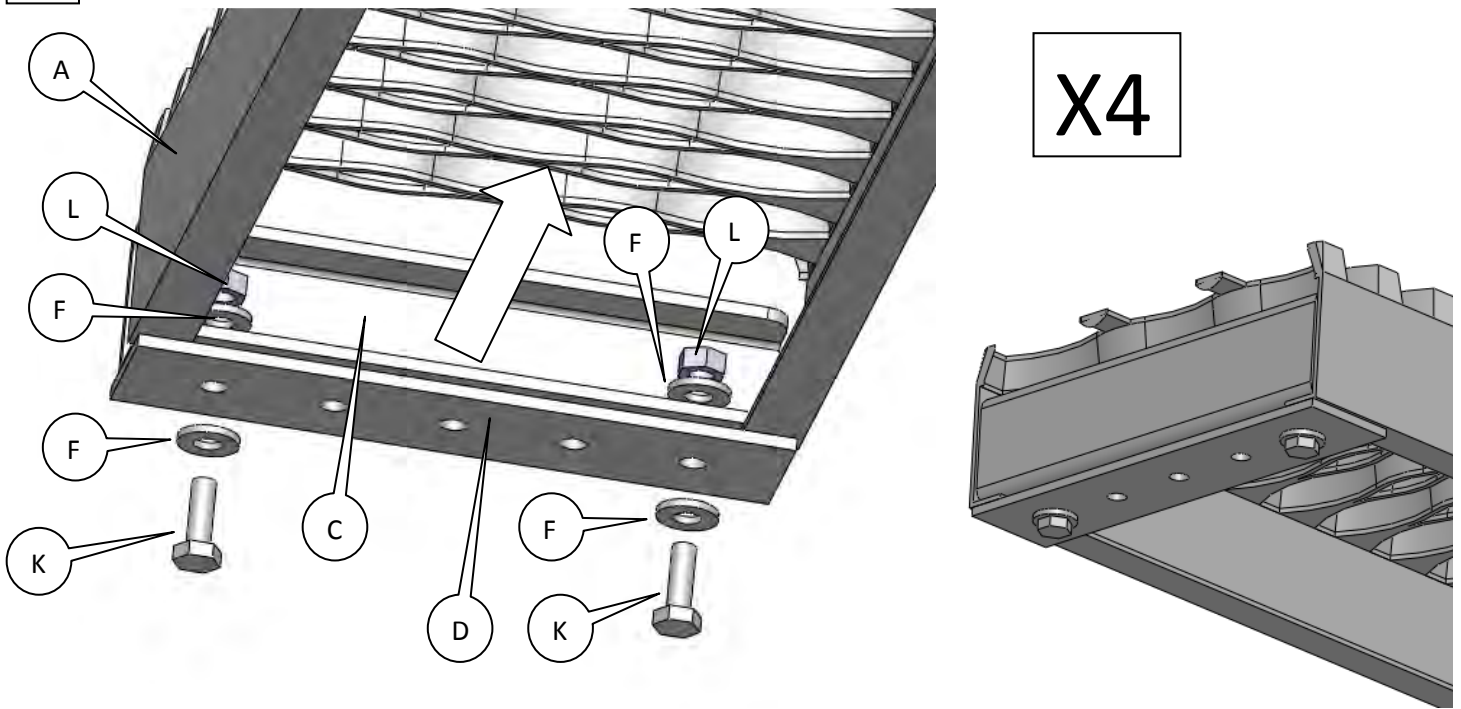

2

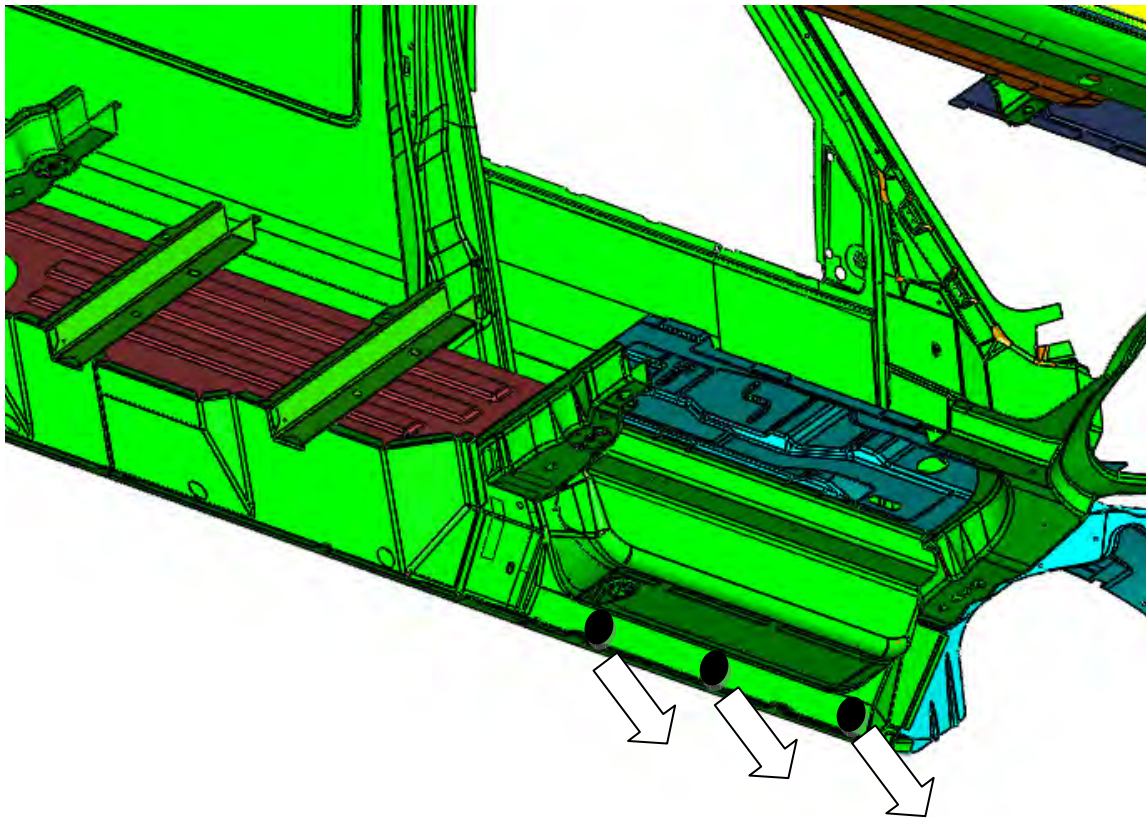

3

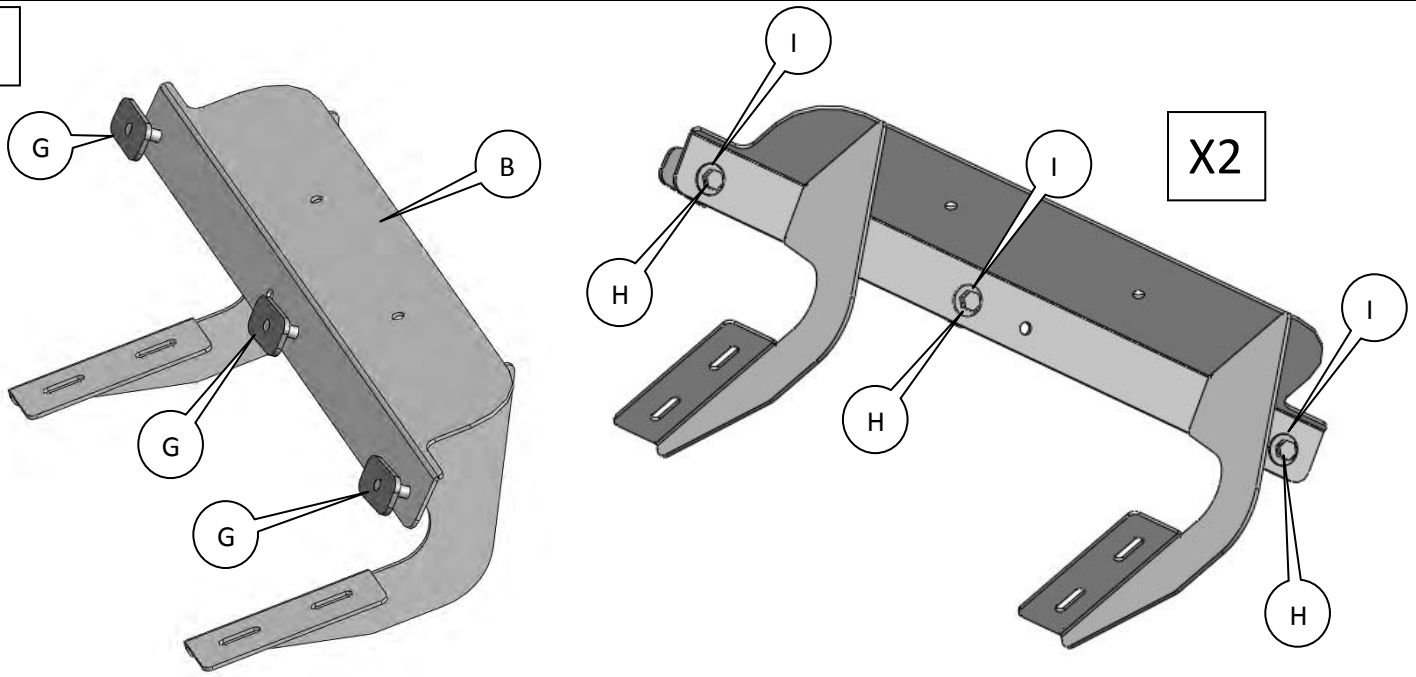

4

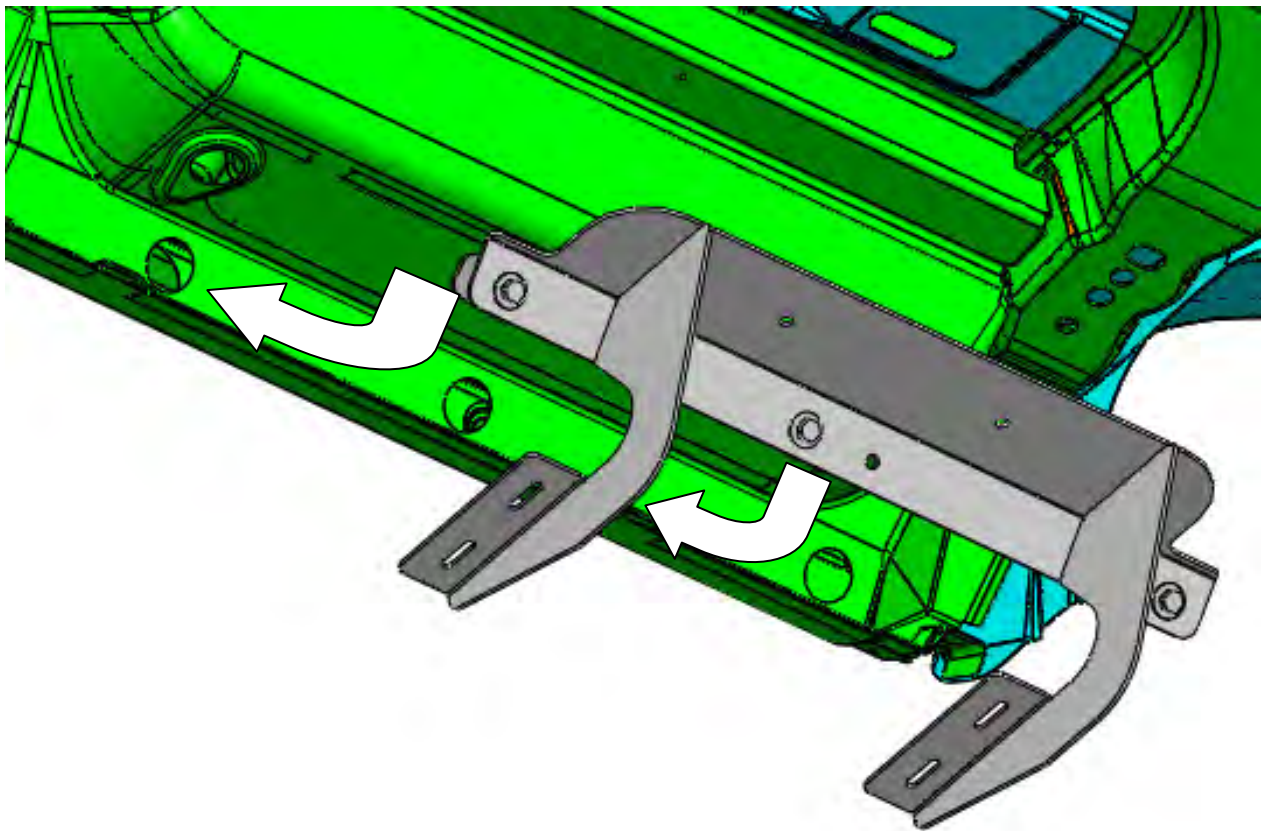

5

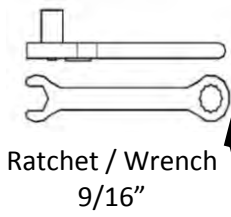
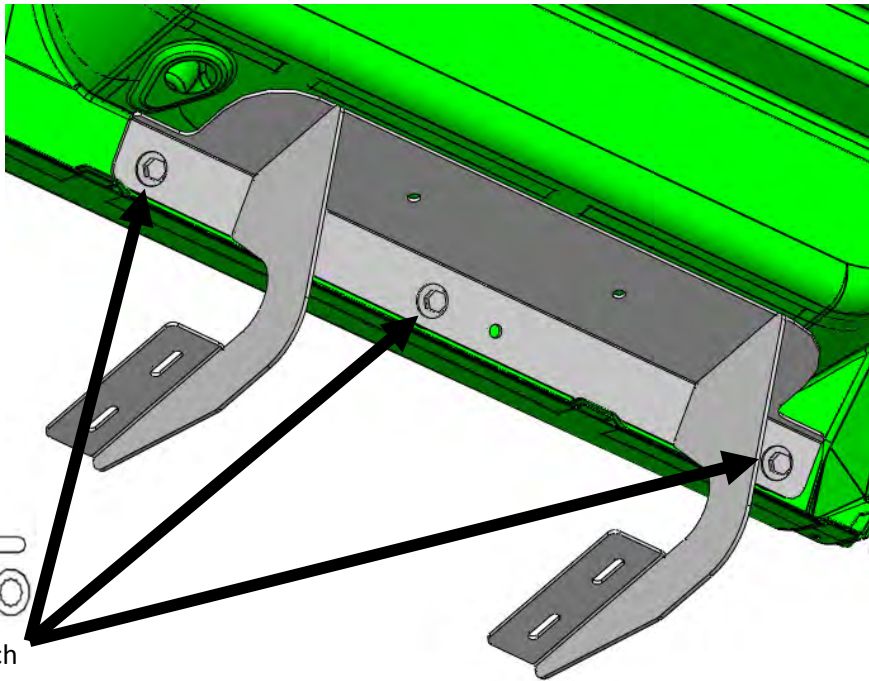

Ratchet / Wrench
9/16"

6

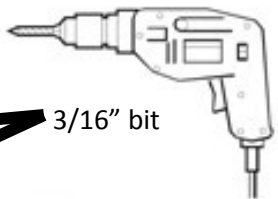
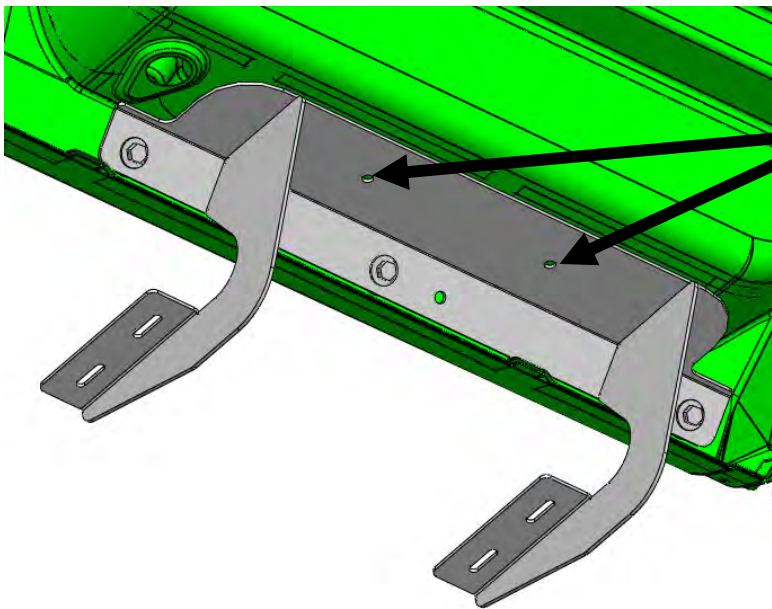

3/16" bit

7

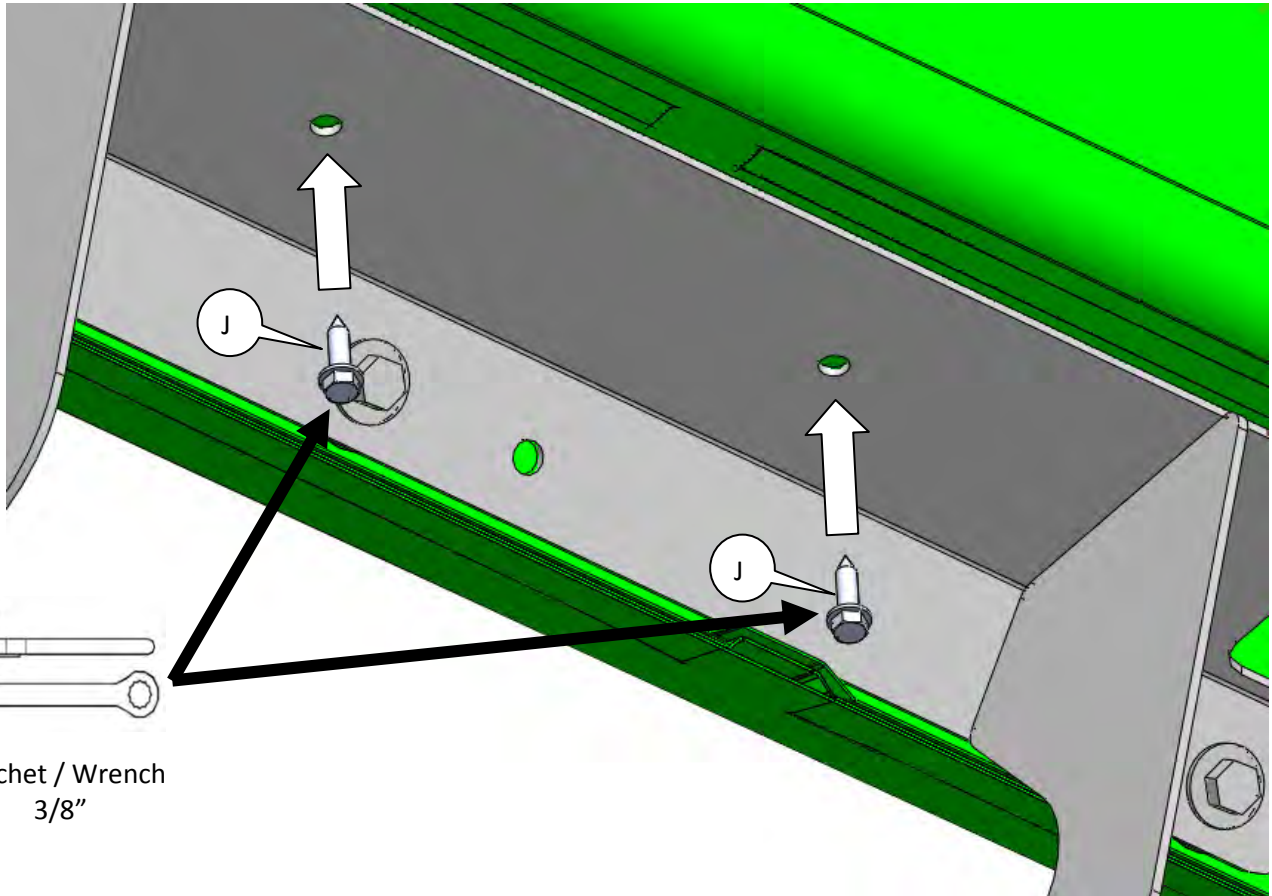

Ratchet / Wrench
3/8"

8

