



**Before returning this product
to the store of purchase**

Contact Dee Zee if you experience the following problems:

- Missing Parts
- Installation Problems/Questions
- Warranty Questions

1.800.779.2102

Hours of operation: 8am - 5pm CST, Mon-Friday

Review complete warranty policy and register your product at:

www.deezee.com



Dee Zee Molded Mudflap Installation Instructions

Congratulations on your purchase of a quality Dee Zee product. Dee Zee is recognized as having the highest quality running boards and accessories on the market today. We have earned this reputation by offering our customers a product they can be proud to place on their vehicles. Dee Zee meets all the criteria of manufacturing a custom-fit product which guarantees it to be the easiest product to install.

Please take time to read all of the instructions before beginning this installation.

If you should happen to have any questions with this product or you have an installation question, please feel free to call us at:

1-800-779-8222

If you would like to find out more information on Dee Zee's products please feel free to visit our website at:

WWW.DEEZEE.COM

Dee Zee Mudflap Installation Instruction

DZ 17940

(1999 - Current) Chevy P/U (Front)

A Rubber
Mudflap



X1 Set

B 1/4 x 1"
Hex Head
Bolt

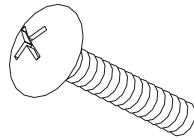

X2

C 1/4" Flat
Washer



PN 265B X2

D 1/4" Hex
Nut



PN 71B X2

E 1/4" Flat
Washer



PN 72B X2

F

3M Protection
Film (10")
(Cut in half)

X1

Tools Required:

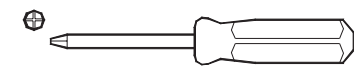

Short Phillips Screwdriver

Ratchet / Wrench

Sizes:

7/16"

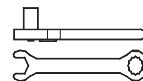

1

3M Protective Film Installation:

Dee Zee mudflaps are designed to fit snugly into the wheel well. To protect your vehicle, Dee Zee has included a 3M protective film.

- 1) Hold the mudflap up to wheel well to determine 3M protective film placement.
- 2) Thoroughly clean the area where the film is to be installed using 3M brand adhesive cleaner or other petroleum distillate based cleaner.
- 3) Cut the film to the proper shape for your application.
- 4) Mix a solution of water and dishwasher detergent into a spray bottle.
- 5) Remove film from the protective liner and spray with the water solution.
- 6) Apply the film to the fender, adhesive side down and spray total area with water solution.
- 7) Remove any air bubbles in film using a wet sponge.
- 8) Let film dry completely before installing mud flap.

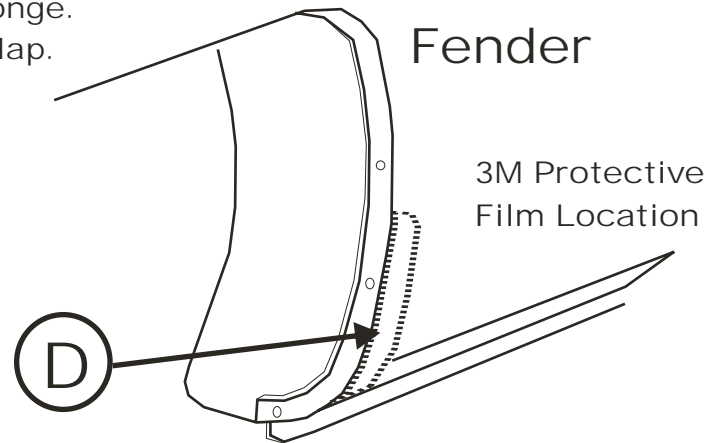

2

Option #1



Remove these screws and save them to re-use them later in the installation.

Remove plugs

Option # 1

- 3 Mark the Wheel Well Liner flush with the bottom of the fender. Cut the extra Wheel Well Liner off. This needs to be done for Option #1 only.



Mark and cut flush.

- 4 Place the mudflap up to the wheel well, over the wheel well liner. Insert the top two screws and washer from Step #1 into the holes. Insert in the bottom hole a 1/4" X 1" Phillips Head Screw (B) and 1/4" Fender Washer (C) then place a 1/4" Flat Washer (E) and 1/4" Nut on the 1/4" X 1" Phillips Head Screw (B).

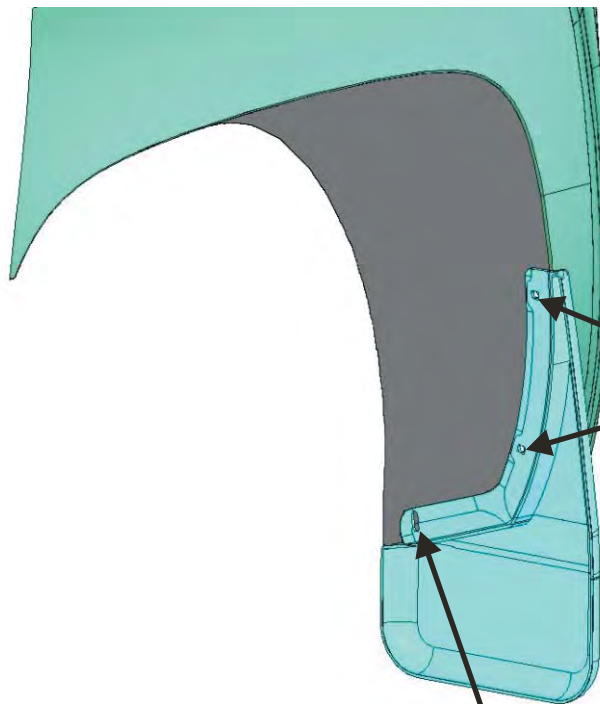

Re-use the screws and washer removed in step #1



Note: Use large washer on this side of mudflap

Option # 2

1/2

See Step #1 and #2 from Option #1 for Step #1 and #2 of Option #2.

3

The Wheel Well Liner does not need to be cut in option #2. The Mudflap slides in between the Wheel Well Liner and the Fender.



The Wheel Well Liner does not need to be cut in Option #2

4

Place the mudflap between the fender well and the wheel well liner. Insert the top two screw and washer from Step #1 into the holes. Insert in the bottom hole a 1/4" X 1" Phillips Head Screw (B) and 1/4" Fender Washer (C) then place a 1/4" Flat Washer (E) and 1/4" Nut on the 1/4" X 1" Phillips Head Screw (B).

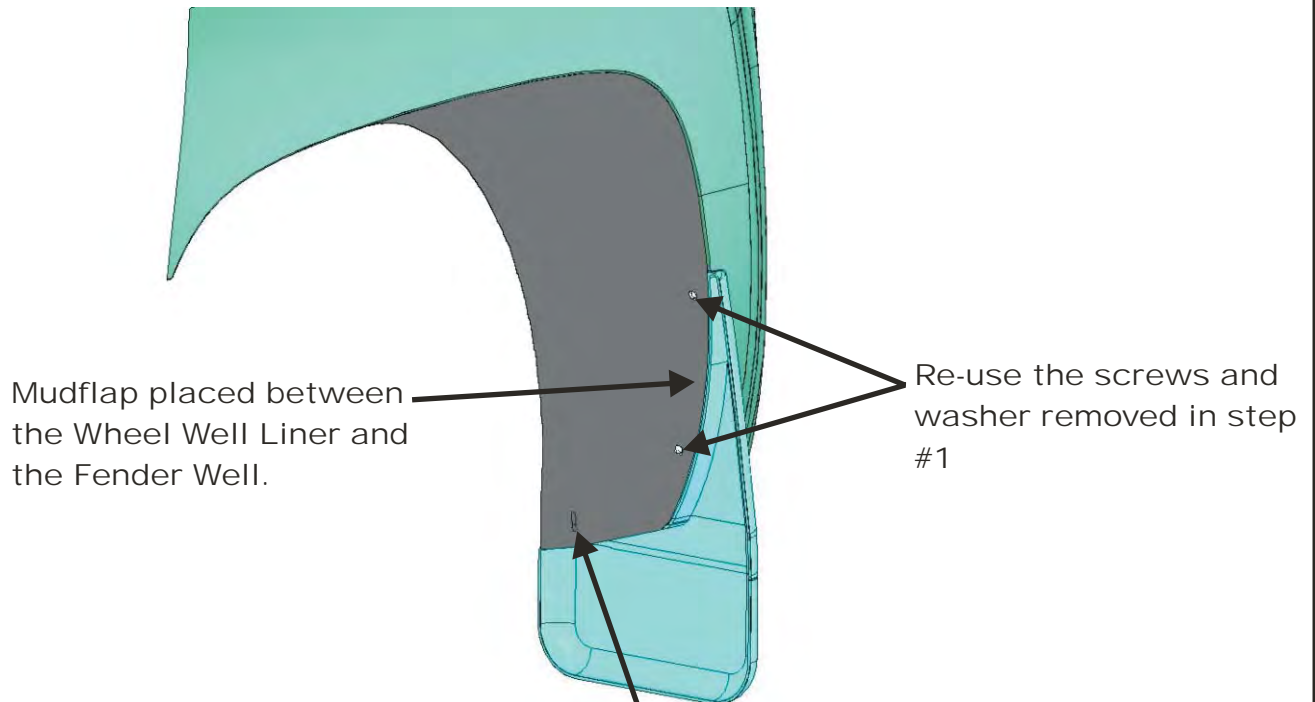

Note: Use large washer on this side of mudflap