



Dee Zee Running Board Installation Instructions

Congratulations on your purchase of a quality Dee Zee product. Dee Zee is recognized as having the highest quality running boards and accessories on the market today. We have earned this reputation by offering our customers a product they can be proud to place on their vehicles. Dee Zee meets all the criteria of manufacturing a custom-fit product which guarantees it to be the easiest product to install.

Note: Please take time to read all of the instructions before beginning this installation.

Warning! Please check for wiring or other obstructions before drilling any holes into the vehicle. If it is necessary to drill any holes into the vehicle, Dee Zee recommends putting a sealant or rust inhibitor around all holes drilled into the body of the vehicle.

Warning! It is the sole responsibility of the vehicle owner to check for tire clearance.

Warning! It is unlawful and dangerous to ride on running boards or side box boards while the vehicle is in motion.

Cleaning Instructions: To maintain the bright finish of your Dee Zee running boards, clean with a mild detergent. For our stainless steel products and accessories, the application of a high grade automotive type wax is recommended.

If you should happen to have any questions with this product or you have an installation question, please feel free to call us at:

1-800-779-8222



















If you would like to find out more information on Dee Zee's products please feel free to visit our website at:

WWW.DEEZEE.COM

Dee Zee Britetread Running Board Installation Instruction

DZ 2037

(1999 - Current) Ford Superduty Super Cab Pickup

A Britetread Running Board  X2	B Britetread Mudflap  X2	C Rocker Panel Bracket  X6	D Running Board Bracket  X6	E 1/4 x 3/4" Hex Head Bolt  X4	F 1/4" Flat Washer  X20
G 1/4" Hex Nut  X16	H 1/4 x 1" Ribneck Carriage Head Bolt  X12	I 3/8 x 1" Hex Head Bolt  X12	J 5/16" Flat Washer  X42	K 3/8" Hex Nut  X12	L 3/8" Lock Washer  X12
M 1/4 x 1" Sheet Metal Screw  X4	N 8mm x 30mm Hex Head Bolt  X12	O 8mm Flange Nut  X6	P 8mm U-Clip  X6	Q Bulb-Seal Gasket  14 ft.	 1/4" Needed 3/16" Needed

Tools Required:

Outils Nécessaires:



Level

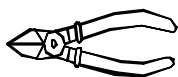

Tin-snips

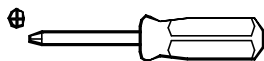

Phillips Head Screwdriver

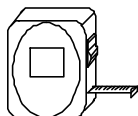

Tape Measure

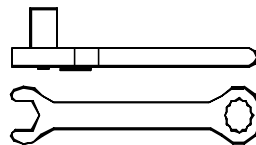

Ratchet / Wrench

Sizes: 3/8"

7/16"

9/16"

13mm

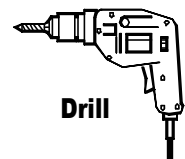

Drill

1

Secure britetread mudflap (B) to britetread running board (A) using 1/4 x 3/4" hex head bolts (E), 1/4" flat washers (F), and 1/4" hex nuts (G). Tighten into place using a 7/16" wrench / or socket. Place bulb-seal gasket (Q) onto the backlip of britetread running board (A) and trim flush with the britetread mudflap (B) and the end of britetread running board (A).

Fixez le mudflap de britetread (b) au panneau courant de britetread (a) en utilisant les boulons de tête d'hexa de 1/4 x de 3/4"(e), les rondelles de 1/4" (f), et les écrous 1/4"d'hexa plats (g). Serrez dans l'endroit à l'aide d'une clé de 7/16"/ou du plot. Placez la garniture d'ampoule-joint (q) sur le backlip du panneau courant de britetread (a) et équilibrez à affleurement du mudflap de britetread (b) et de l'extrémité du panneau courant de britetread (a).

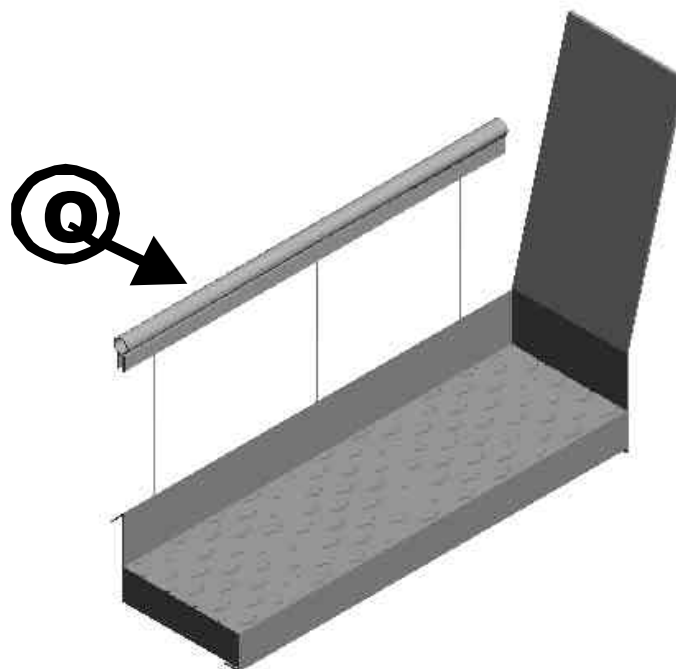
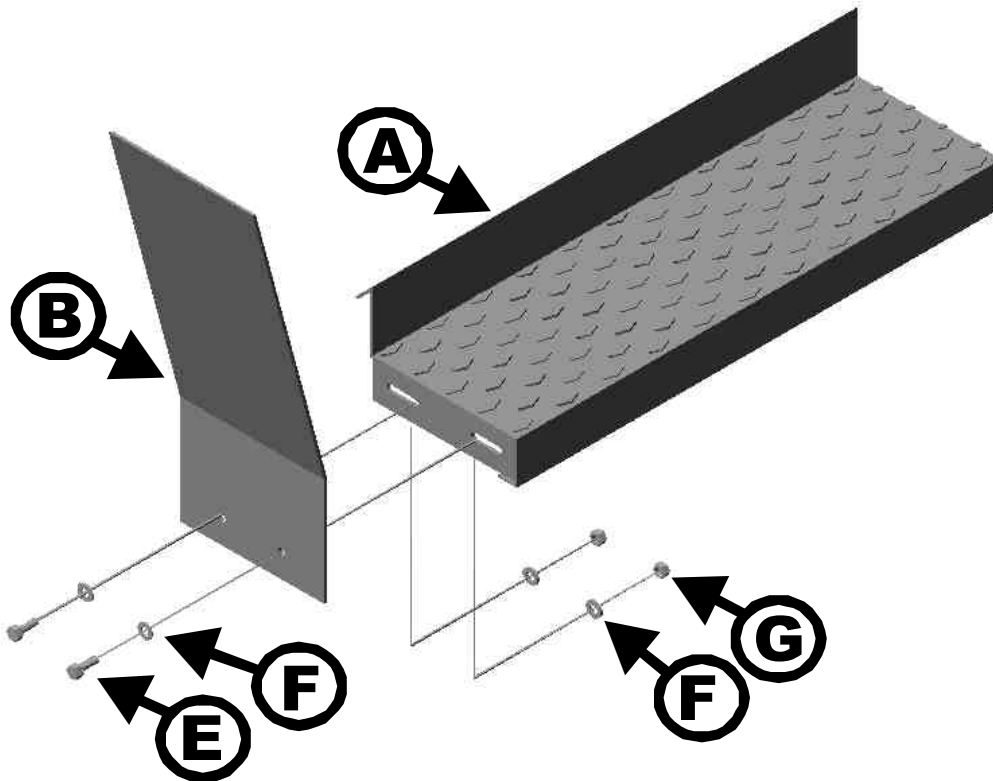

**Britetread
Running Board**

7/16" Wrench
or Socket

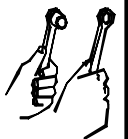

2

Locate the existing holes in the vehicle rocker panels as shown below. Place an 8mm u-clip (P) onto the holes shown below and press firmly into place.

Trouvez les trous existants dans le panneau de culbuteur de véhicule comme montré ci-dessous. Placez un u-clip de 8 mm (p) dans les trous montrés ci-dessous et appuyez fermement dans l'endroit.

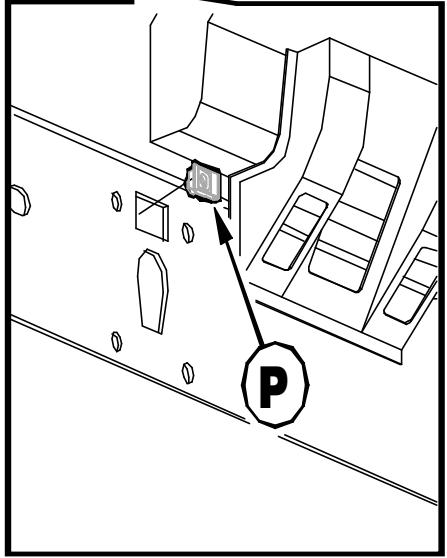
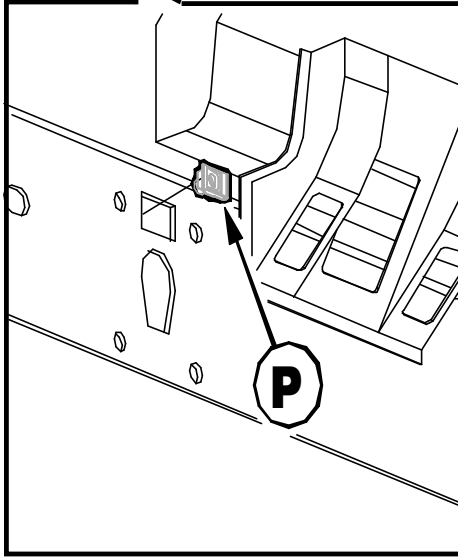
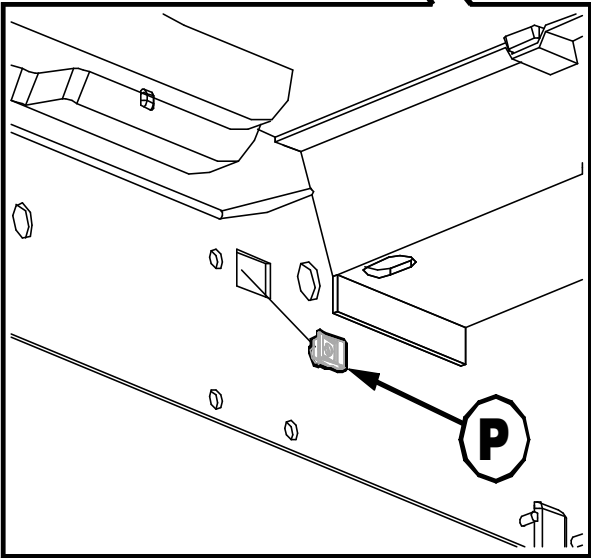
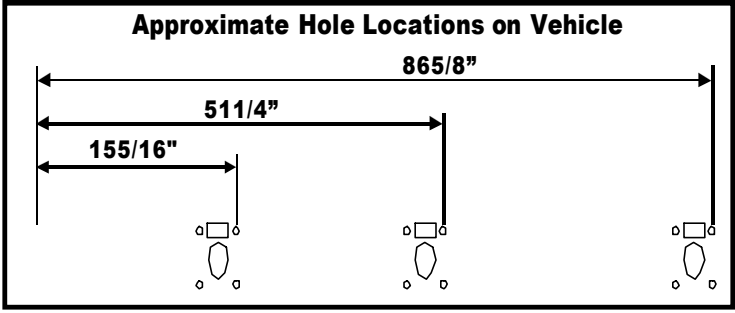
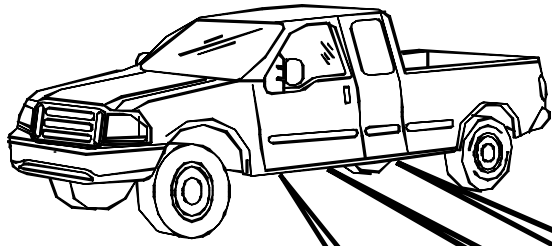

U-Clip Installed Correctly

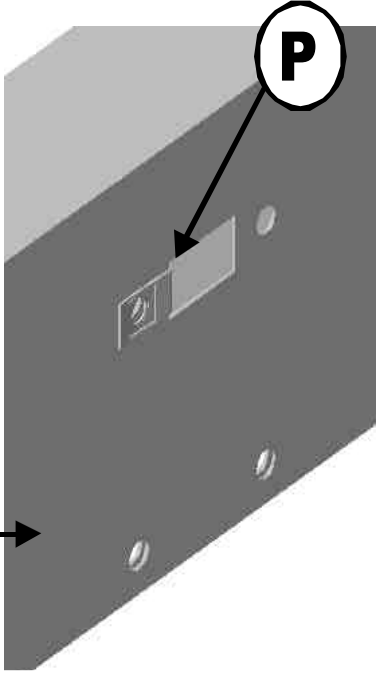

Vehicle Rocker Panel



3

Using the drawing below as a guide identify the rocker panel bracket and its correct position on the vehicle.

Note: The open face of rocker panel bracket (C) will face the rear of the vehicle on the driver side of the vehicle.

Note: The open face of rocker panel bracket (C) will face the front of the vehicle on the passenger side of the vehicle.

Align the top hole as shown below with the 8mm u-clip (P) and secure into place using an 8mm x 30mm hex head bolt (N) and 5/16" flat washer (J). Now secure the bottom hole in the rocker panel bracket (C) to the hole in the bottom of the vehicle rocker panel using an 8mm x 30mm hex head bolt (N), 5/16" flat washers (J), and 8mm flange nut (O). Leave fasteners loose for later adjustment.

En utilisant le schéma ci-dessous comme guide identifiez la parenthèse de panneau de culbuteur et sa position correcte sur le véhicule. **Note :** Le visage ouvert de la parenthèse de panneau de culbuteur (c) fera face à l'arrière du véhicule du côté de gestionnaire du véhicule. **Note :** Le visage ouvert de la parenthèse de panneau de culbuteur (c) fera face à l'avant du véhicule du côté de passager du véhicule. Alignez le trou supérieur comme montré ci-dessous avec l'u-clip de 8mm (p) et le fixez dans l'endroit en utilisant un boulon de tête d'hexa de 8mm x de 30mm (n) et la rondelle plate de 5/16" (j). Fixez maintenant le trou inférieur dans la parenthèse de panneau de culbuteur (c) au trou dans le bas du panneau de culbuteur de véhicule à l'aide d'un boulon de tête d'hexa de 8mm x de 30mm (n), des rondelles plates de 5/16" (j), et de l'écrou de bride de 8mm (o). Laissez les attaches lâches pour le réglage postérieur.

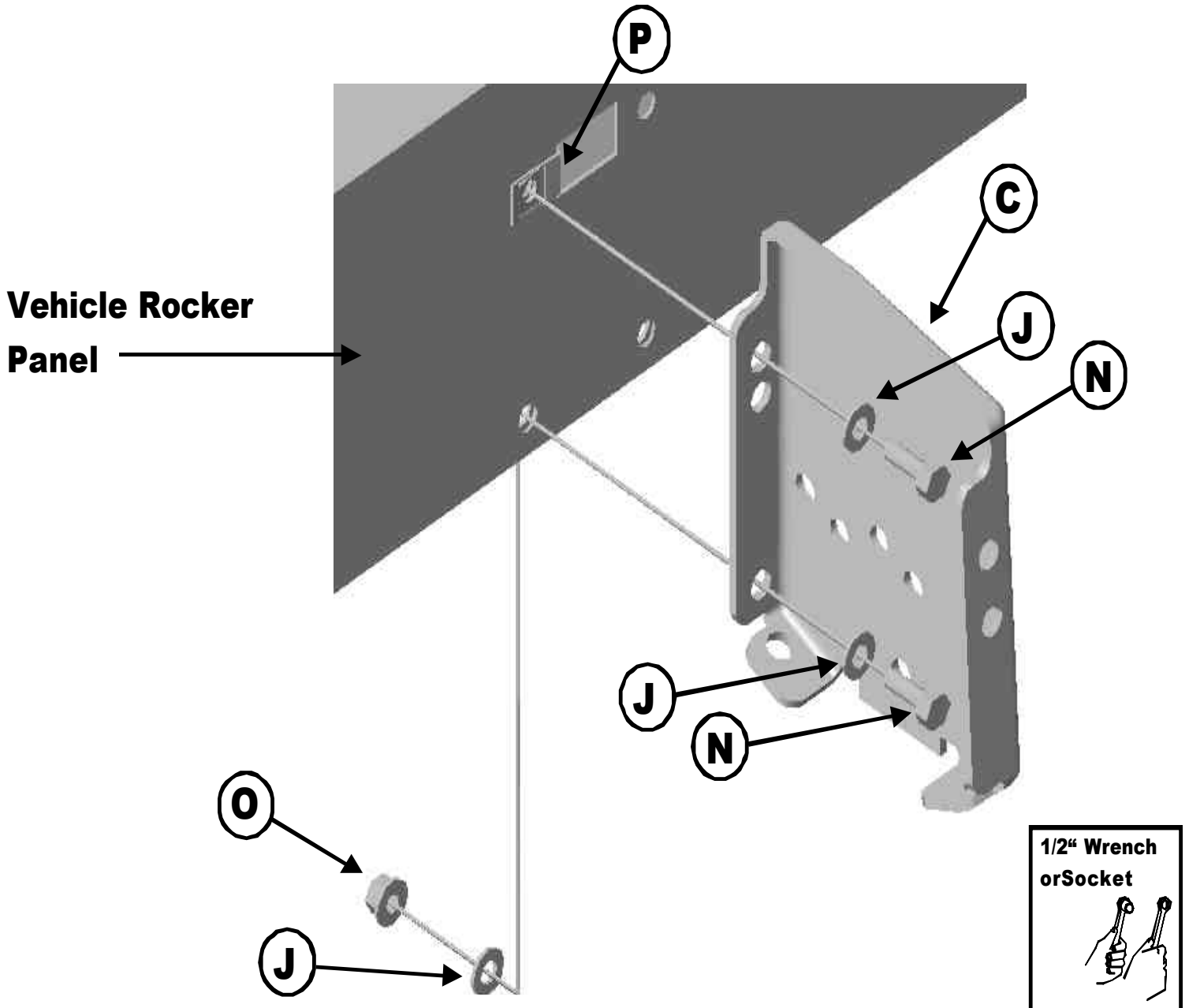

4

Using the drawing below as a guide, place running board bracket (D) up to rocker panel bracket (C). Secure the rear-top hole in running board bracket (D) to the hole in the rocker panel bracket (C) using 3/8 x 1" hex headbolt (I), 5/16" flat washers (J), 3/8" lockwasher (L), and 3/8" hex nut (K). Note: See drawings below for correct hole identification.

En utilisant le schéma ci-dessous comme guide, placez la parenthèse courante de panneau (d) jusqu'à la parenthèse de panneau deculbuteur (c). Fixez le trou d'arrière-dessus dans la parenthèse courante de panneau (d) au trou dans la parenthèse de panneau deculbuteur (c) à l'aide d'un boulon de tête d'hexa de 3/8 x de 1" (i), des rondelles plates de 5/16" (j), de la rondelle de freinage de 3/8" (l), et de l'écrou d'hexa de 3/8" (k). Note : Voir les dessins ci-dessous pour l'identification correcte de trou.

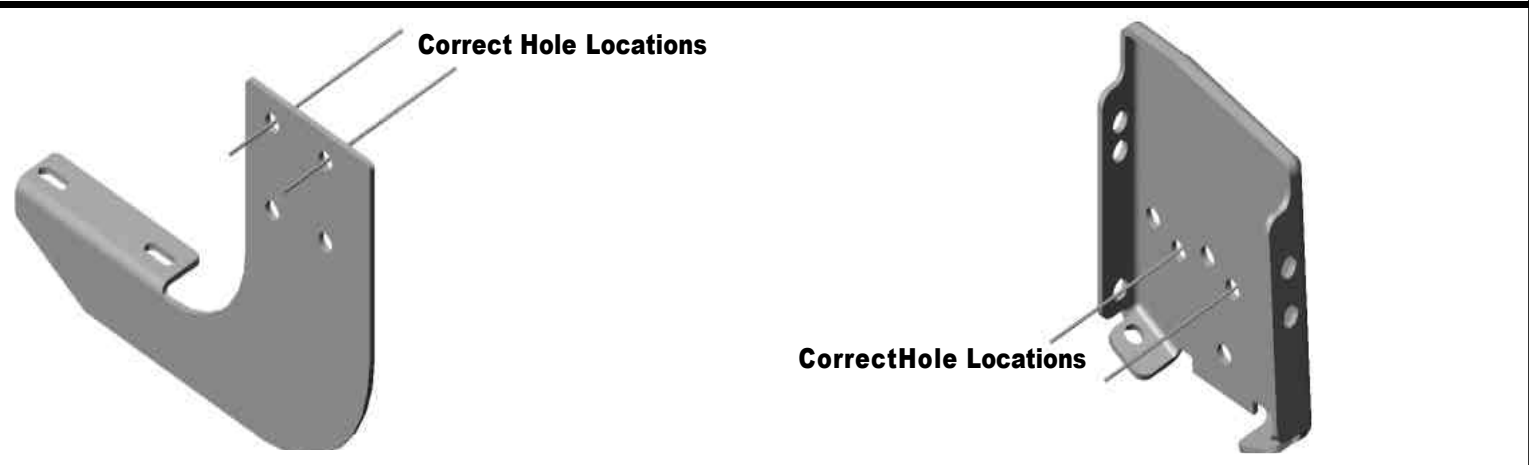
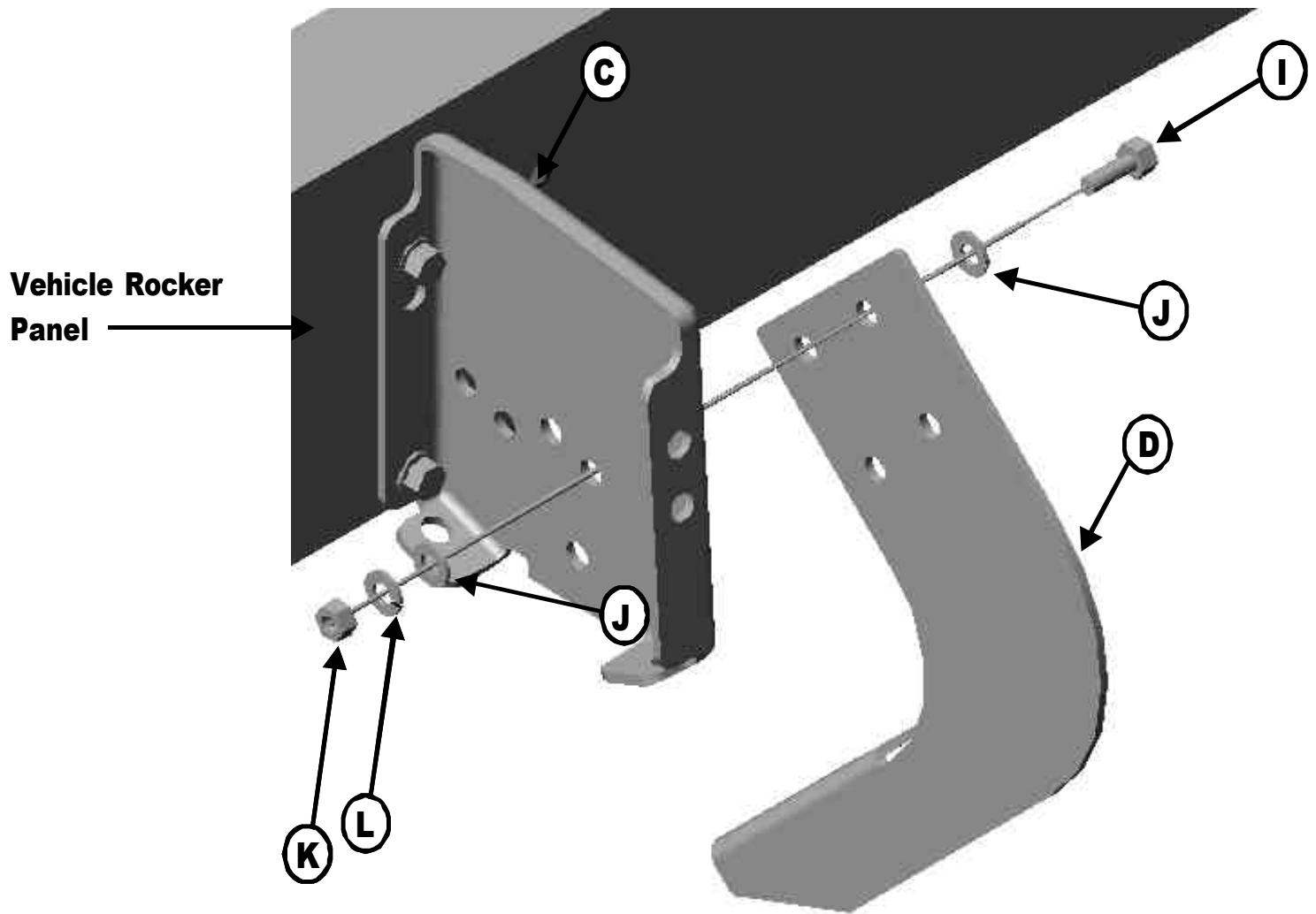

5

Rotate the running board bracket to the upright position and secure it into place using a 3/8x1" hex head bolt (I), 3/8" lock washer (L), 5/16" flat washers (J), and 3/8" hex nuts (K) as shown below.

Tournez le panneau courant jusqu'à la position droite et fixez-le dans l'endroit à l'aide d'un boulon de tête d'hex de 3/8 x de 1" (i), de la rondelle de freinage de 3/8" (l), des rondelles plates de 5/16" (j), et des écrous d'hex de 3/8" (k) comme montré ci-dessous.

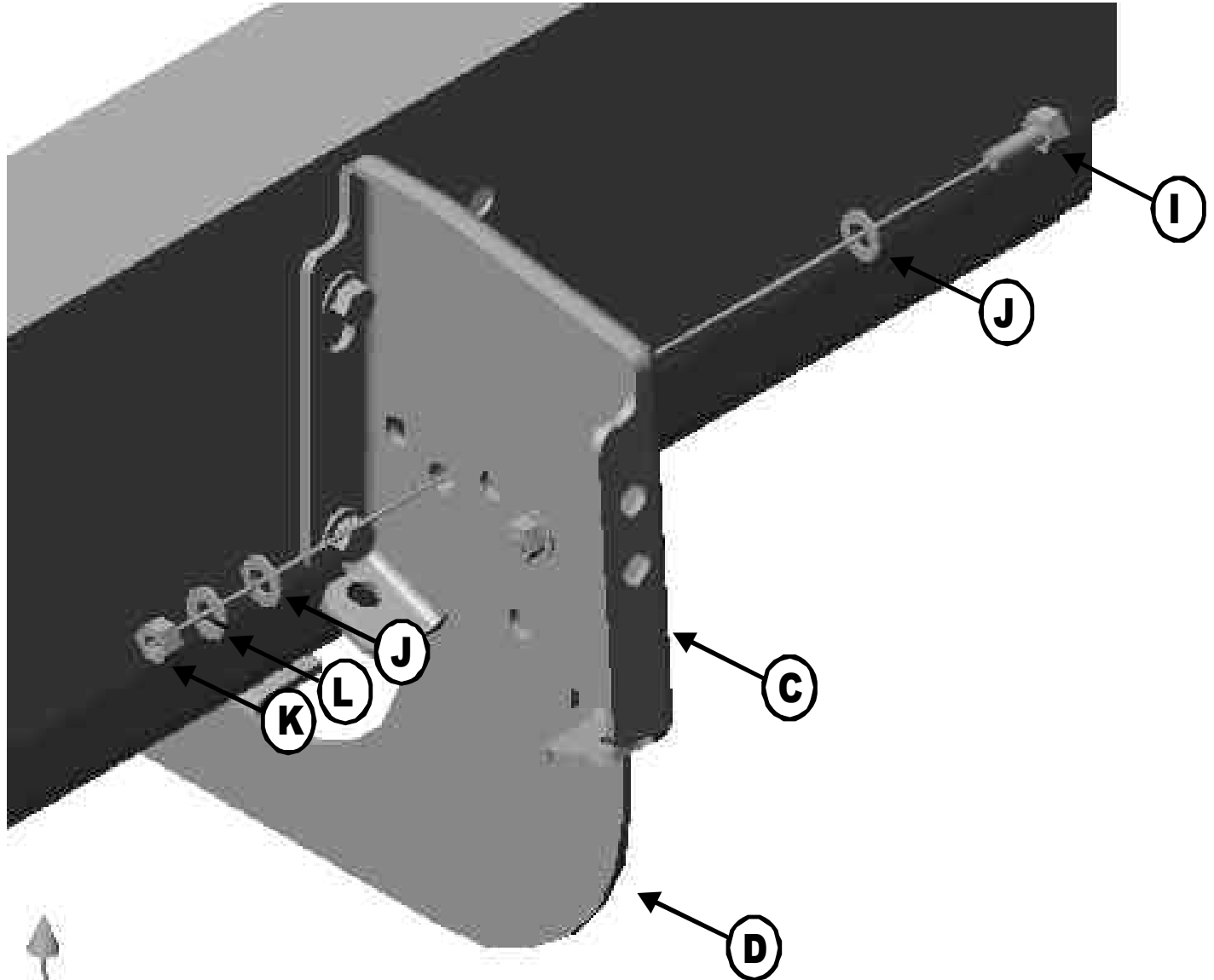

Rotate

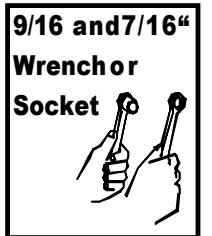

6

Place britetread running board (A) up to the running board brackets (D) as shown below. Slide the britetread running board up to the rocker panel so that it is flush with the vehicle rocker panel.

Placez le panneau courant de britetread (a) jusqu'aux parenthèses de panneau de fonctionnement (d) comme montré ci-dessous. Glissez le panneau courant de britetread jusqu'au panneau de culbuteur de sorte qu'il soit affleurant du panneau de culbuteur de véhicule.

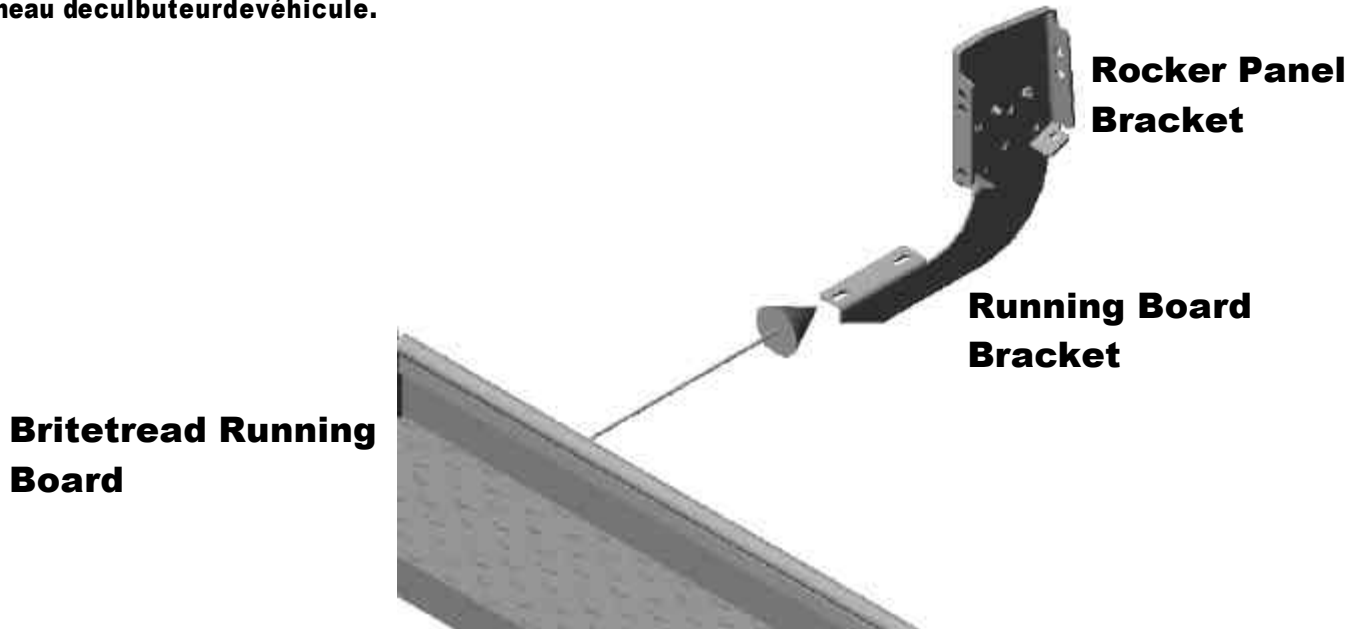

Side View of rocker panel bracket and britetread running board assembly.

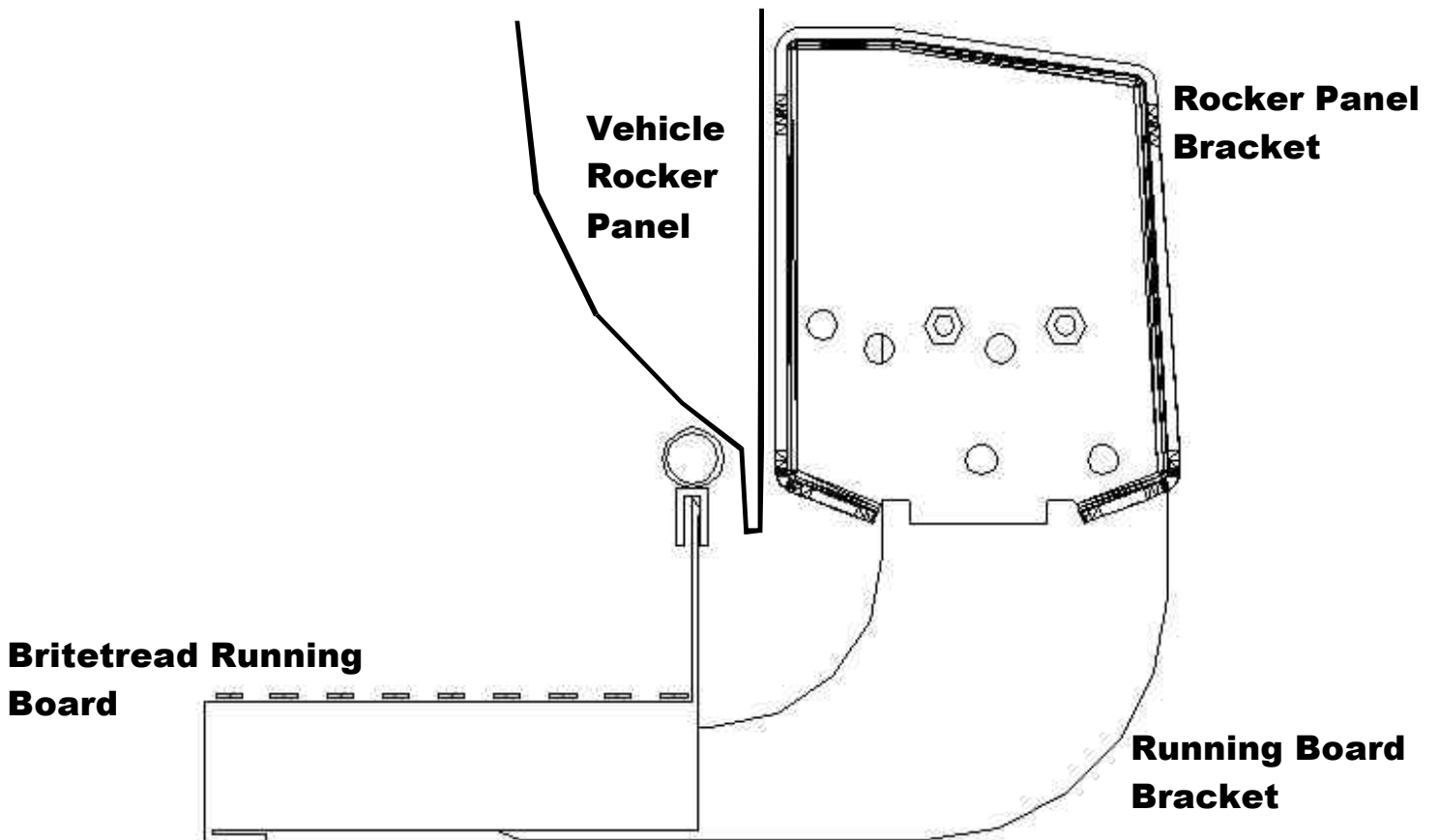

7

Using the bottom holes in the running board bracket (D) as a guide, drill 1/4" holes through the britetread running board. Secure the running board bracket (D) to the britetread running board using 1/4 x 1" ribneck carriage head bolts (H), 1/4" flat washers (F), and 1/4" hex nuts (G). Tighten into place using a 7/16" wrench / or socket.

En utilisant les trous de bas dans le panneau courant encadrez (d) comme guide, forent des trous de 1/4" par le panneau courant de britetread. Fixez la paranthèse courant de panneau (d) au panneau courant de britetread en utilisant les boulons de tête de chariot de ribneck de 1/4 x 1" (h), les rondelles de 1/4" (f), et les écrous 1/4" d'hexaplat (g). Serrez dans l'endroit à l'aide d'une clé de 7/16" ou du plot.

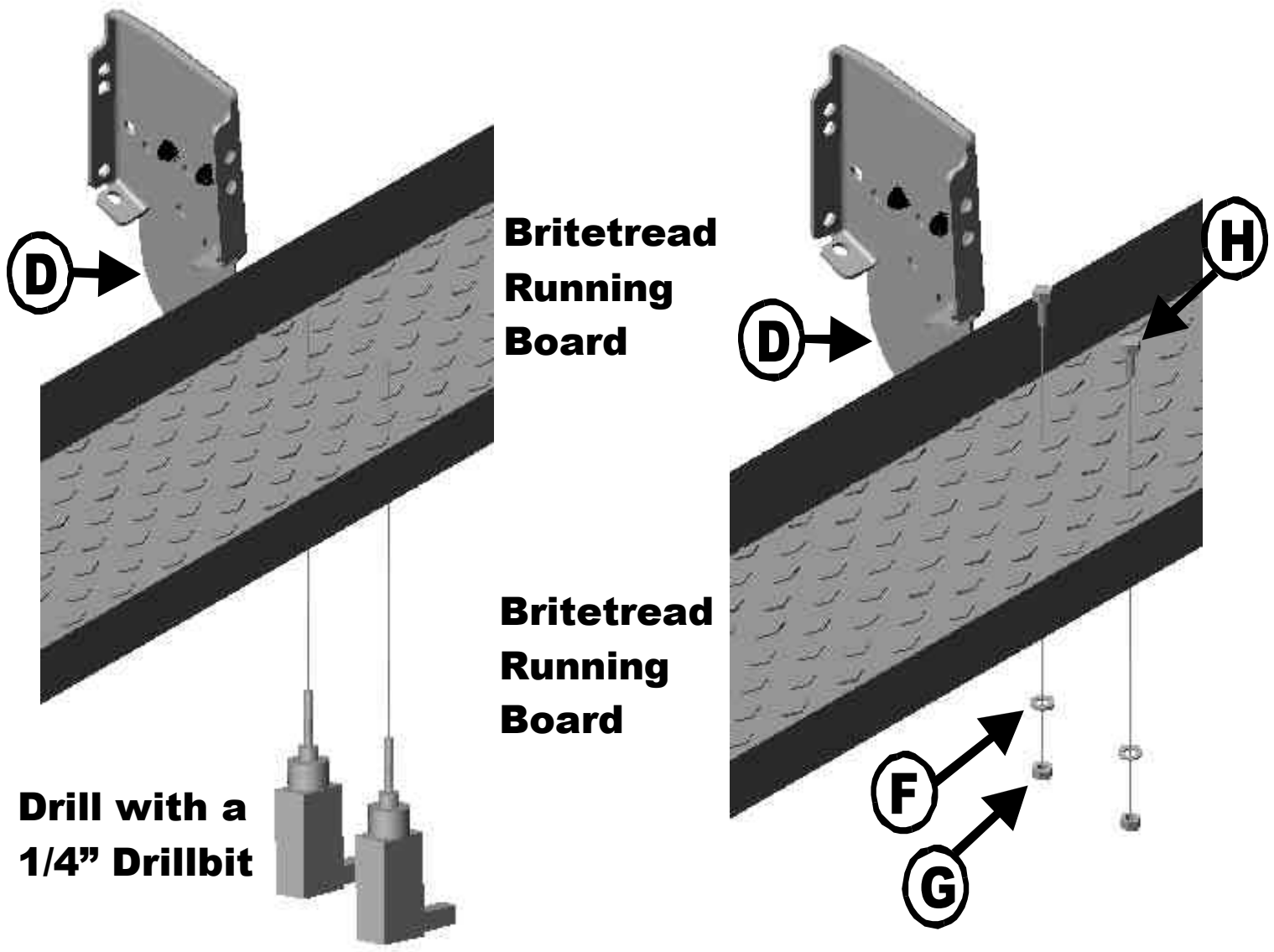
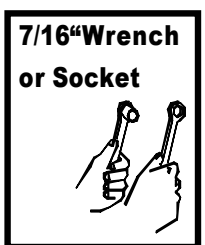
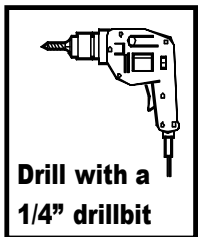

8

Drill two holes through the britetread mudflap and the sheet metal of the vehicle wheel well opening. Secure the britetread mudflap to the vehicle wheel well opening using 1/4 x 1" sheet metal screws (M). Tighten into place using a 3/8" wrench / or socket.

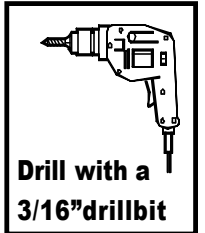

Forez deux trous par le mudflap de britetread et le métal de feuille de l'ouverture de soute de train de véhicule. Fixez le mudflap de britetread à l'ouverture de soute de train de véhicule à l'aide des vis en métal de feuille de 1/4 x de 1"(mj). Serrez dans l'endroit à l'aide d'une clé de 3/8"/ou du plot.

