



**Before returning this product
to the store of purchase**

Contact Dee Zee if you experience the following problems:

- Missing Parts
- Installation Problems/Questions
- Warranty Questions

1.800.779.2102

Hours of operation: 8am - 5pm CST, Mon-Friday

Review complete warranty policy and register your product at:

www.deezee.com



Dee Zee Running Board Installation Instructions

Congratulations on your purchase of a quality Dee Zee product. Dee Zee is recognized as having the highest quality running boards and accessories on the market today. We have earned this reputation by offering our customers a product they can be proud to place on their vehicles. Dee Zee meets all the criteria of manufacturing a custom-fit product which guarantees it to be the easiest product to install.

Note: Please take time to read all of the instructions before beginning this installation.

Warning! Please check for wiring or other obstructions before drilling any holes into the vehicle. If it is necessary to drill any holes into the vehicle, Dee Zee recommends putting a sealant or rust inhibitor around all holes drilled into the body of the vehicle.

Warning! It is the sole responsibility of the vehicle owner to check for tire clearance.

Warning! It is unlawful and dangerous to ride on running boards or side box boards while the vehicle is in motion.

Cleaning Instructions: To maintain the bright finish of your Dee Zee running boards, clean with a mild detergent. For our stainless steel products and accessories, the application of a high grade automotive type wax is recommended.

If you should happen to have any questions with this product or you have an installation question, please feel free to call us at:

1-800-779-8222











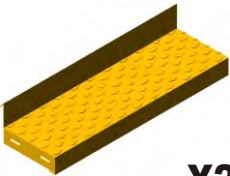





If you would like to find out more information on Dee Zee's products please feel free to visit our website at:

WWW.DEEZEE.COM

Dee Zee Britetread Running Board Installation Instruction

DZ 2040

(2004 - Current) Ford F150 Regular Cab Pickup

<p>A Britetread Running Board</p>  <p style="text-align: right;">X2</p>	<p>B Britetread Mudflap</p>  <p style="text-align: right;">X2</p>	<p>C Rocker Panel Bracket</p>  <p style="text-align: right;">X4</p>	<p>D Running Board Bracket</p>  <p style="text-align: right;">X4</p>	<p>E 1/4 x 3/4" Hex Head Bolt</p>  <p style="text-align: right;">X4</p>	<p>F 1/4" Flat Washer</p>  <p style="text-align: right;">X16</p>
<p>G 1/4" Hex Nut</p>  <p style="text-align: right;">X12</p>	<p>H 1/4 x 1" Ribneck Carriage Head Bolt</p>  <p style="text-align: right;">X8</p>	<p>I 3/8 x 1" Hex Head Bolt</p>  <p style="text-align: right;">X8</p>	<p>J 5/16" Flat Washer</p>  <p style="text-align: right;">X16</p>	<p>K 3/8" Hex Nut</p>  <p style="text-align: right;">X8</p>	<p>L 3/8" Lock Washer</p>  <p style="text-align: right;">X8</p>
<p>M 1/4 x 1" Sheet Metal Screw</p>  <p style="text-align: right;">X4</p>	<p>N 8mm x 25mm Hex Head Bolt</p>  <p style="text-align: right;">X8</p>	<p>P 8mm U-Clip</p>  <p style="text-align: right;">X8</p>	<p>Q Bulb-Seal Gasket</p>  <p style="text-align: right;">10.5 ft.</p>		

Tools Required:
Outils Nécessaires:

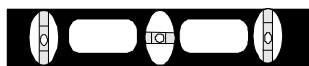

Level

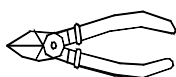

Tin-snips

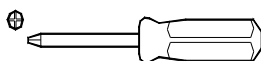

Phillips Head Screwdriver

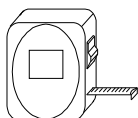

Tape Measure

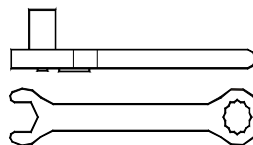

Ratchet / Wrench

Sizes: 3/8"
7/16"
9/16"
13mm

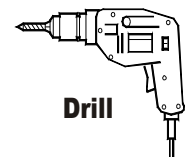

Drill

1/4" Drill Bit
3/16" Drill bit

1

Secure britetread mudflap (B) to britetread running board (A) using 1/4 x 3/4" hex head bolts (E), 1/4" flat washers (F), and 1/4" hex nuts (G). Tighten into place using a 7/16" wrench / or socket. Place bulb-seal gasket (Q) onto the backlip of britetread running board (A) and trim flush with the britetread mudflap (B) and the end of britetread running board (A).

Fixez le mudflap de britetread (b) au panneau courant de britetread (a) en utilisant les boulons de tête d'hexa de 1/4 x de 3/4"(e), les rondelles de 1/4" (f), et les écrous 1/4"d'hexa plats (g). Serrez dans l'endroit à l'aide d'une clé de 7/16"/ou du plot. Placez la garniture d'ampoule-joint (q) sur le backlip du panneau courant de britetread (a) et équilibrez à affleurement du mudflap de britetread (b) et de l'extrémité du panneau courant de britetread (a).

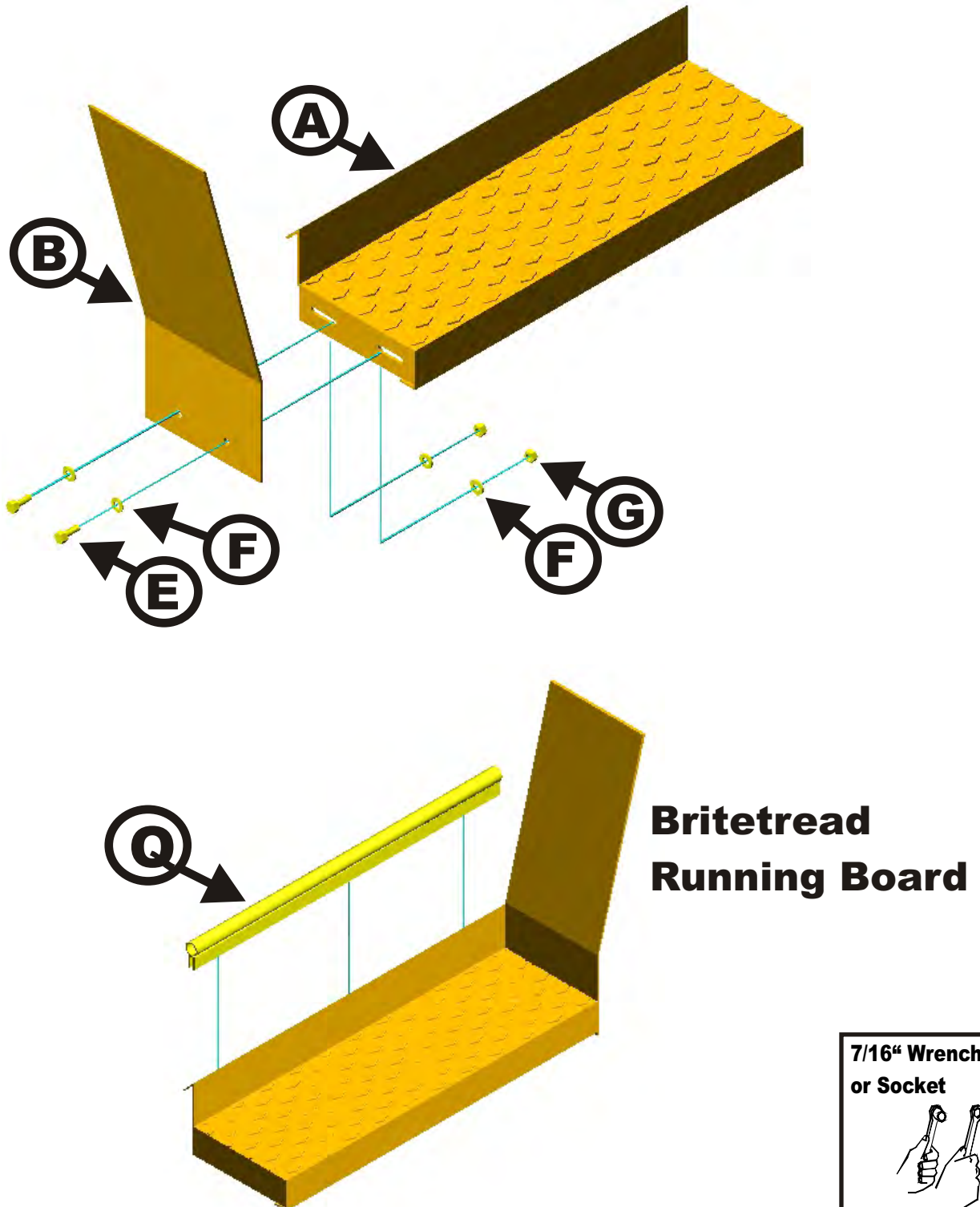

7/16" Wrench
or Socket

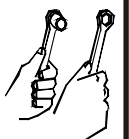

2

You will need to remove the black tape from the rocker panel and then place an 8mm u-clip (P) into the hole locations shown below.

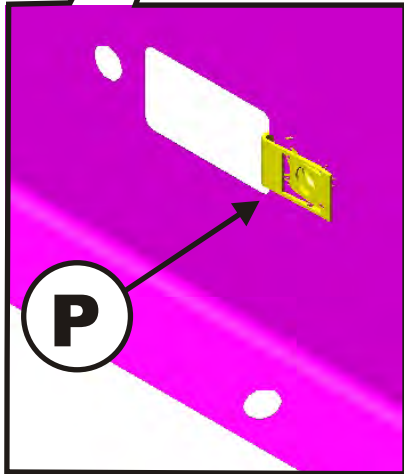
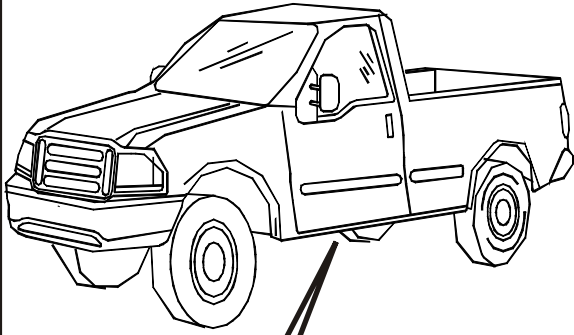

Approximate Hole Locations on Vehicle

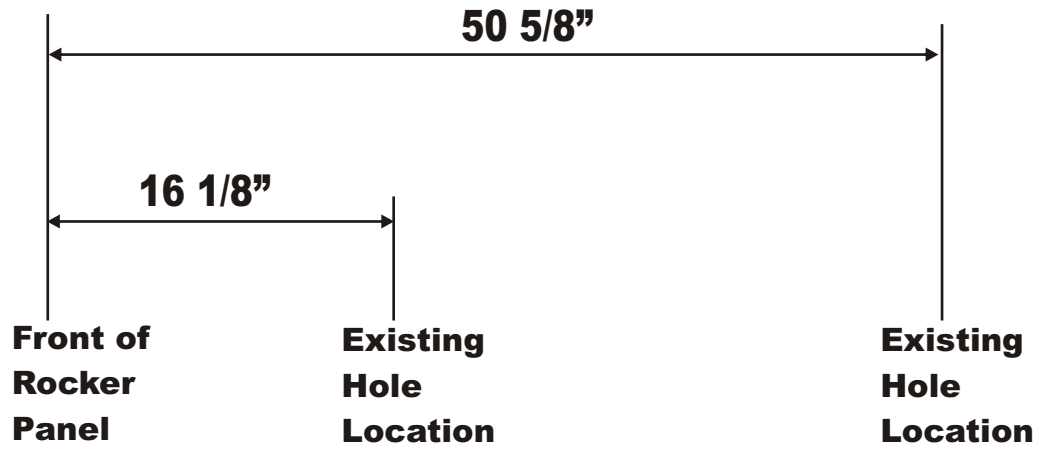

3

Slide 8mm u-clip (P) onto the rocker panel bracket (C) as shown below. Make sure that the hole in 8mm u-clip (O) is aligned with the hole in rocker panel bracket (C).

Diapositive l'u-agrafe de 8mm (p) sur la parenthèse de panneau de culbuteur (c) comme montré ci-dessous. Assurez-vous que le trou dans l'u-agrafe de 8mm (o) est aligné avec le trou dans la parenthèse de panneau de culbuteur (c).

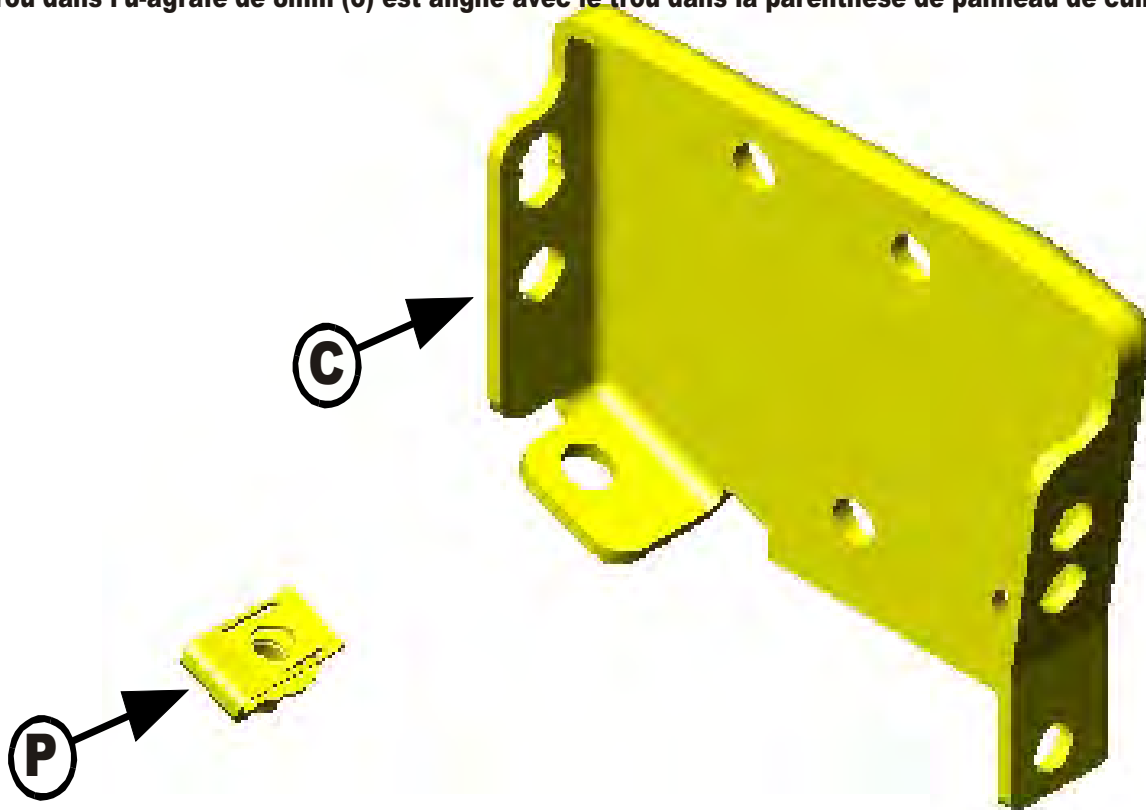

**Brace
Assembly**



4 Front and Rear Brace Installation

Place the rocker panel bracket (C) up to the vehicle rocker panel and u-clip (p) and secure into place using an 8mm x 30mm flange head bolt (N) as shown below.

Placez la parenthèse de panneau de culbuteur (c) jusqu'au panneau de culbuteur de véhicule et à l'u-agrafe (p) et la fixez dans l'endroit à l'aide d'un boulon de tête de bride de 8mm x de 30mm (n) comme montré ci-dessous.

13mm Wrench
or Socket

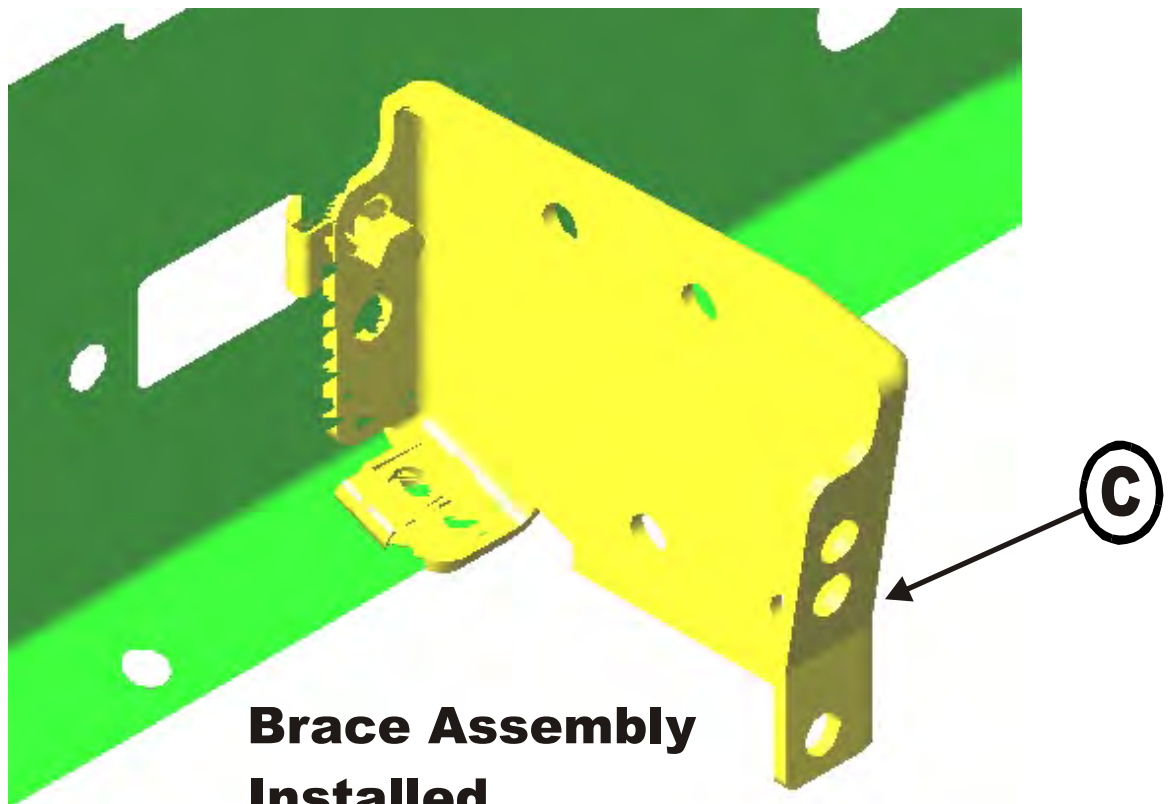
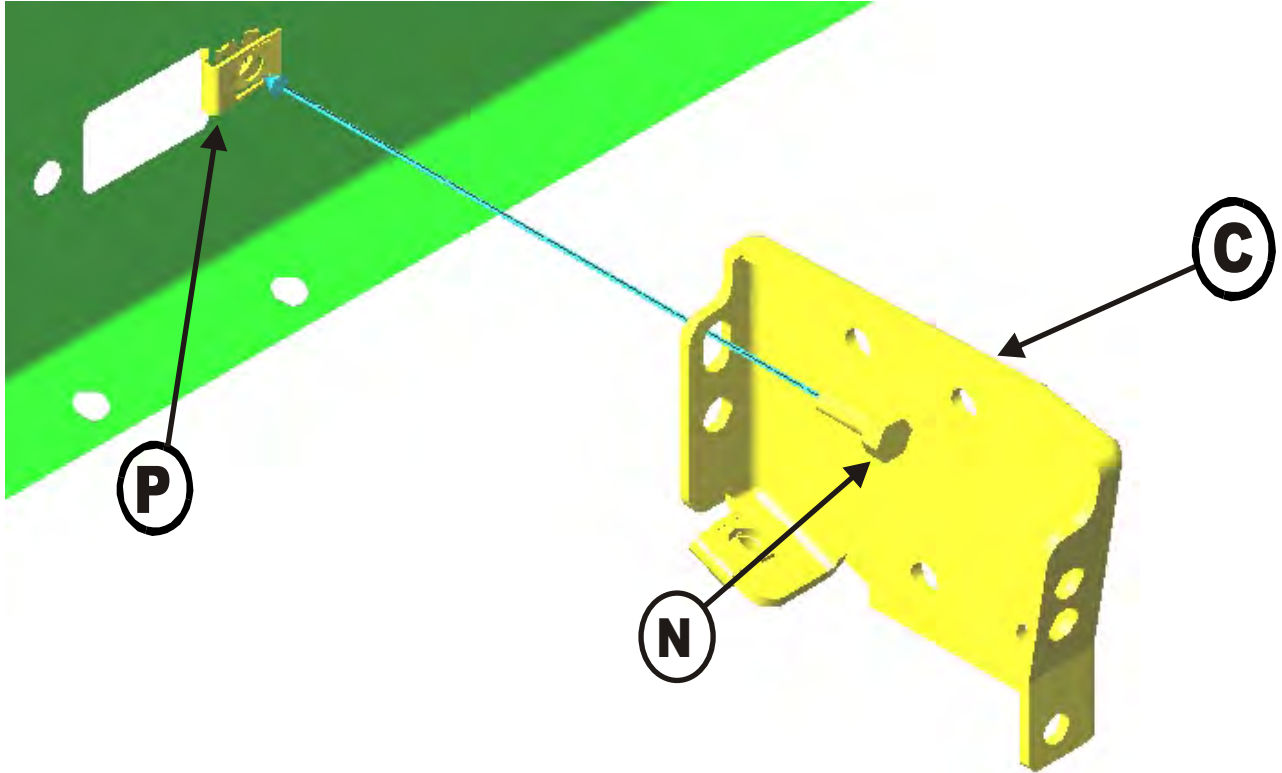
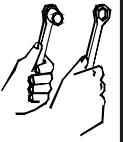

**Brace Assembly
Installed**

5 Front and Rear Brace Installation

Secure the 8mm u-clip in the bottom flange on rocker panel bracket (C) to the rocker panel using 8mm x 25mm flange head bolt (N).

Asegure el u-clip de 8m m en el reborde inferior en el soporte del panel del eje de balancín (c) al panel del eje de balancín usando el perno de la cabeza del reborde de 8m m x de 25m m (n).

13mm Wrench
or Socket

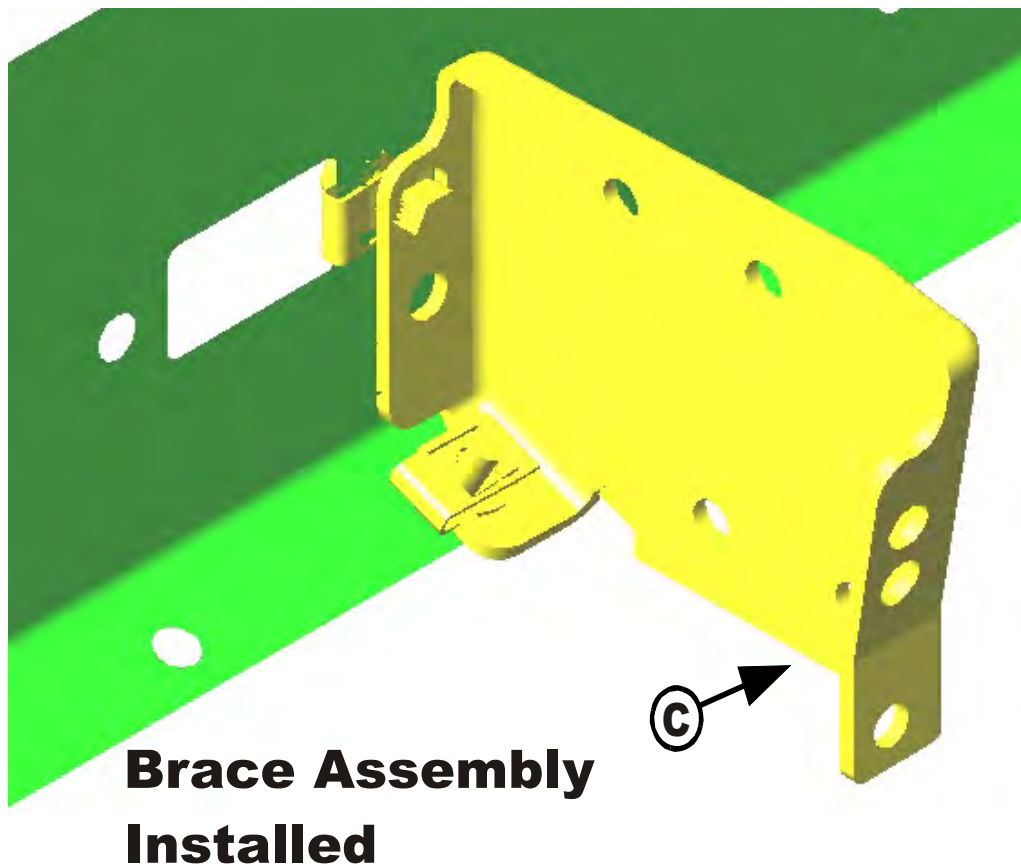
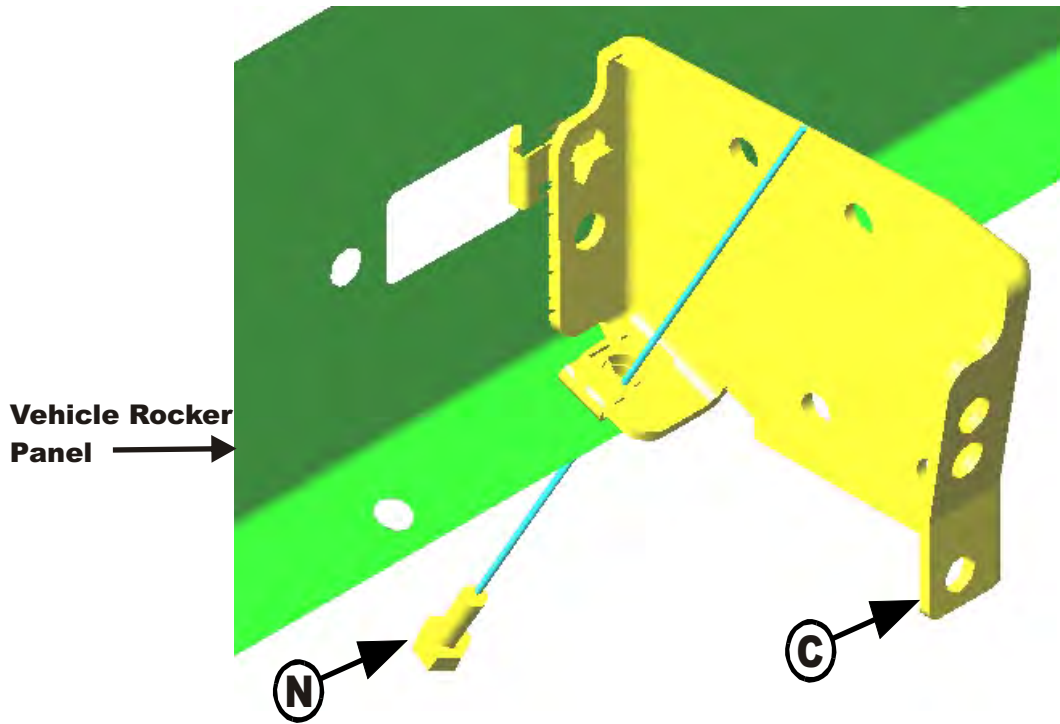
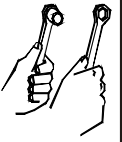

6

Using the drawing below as a guide, place running board bracket (D) up to rocker panel bracket (C). Secure the rear-top hole in running board bracket (D) to the hole in the rocker panel bracket (C) using 3/8 x 1" hex head bolt (I), 5/16" flat washers (J), 3/8" lock washer (L), and 3/8" hex nut (K). Note: See drawings below for correct hole identification.

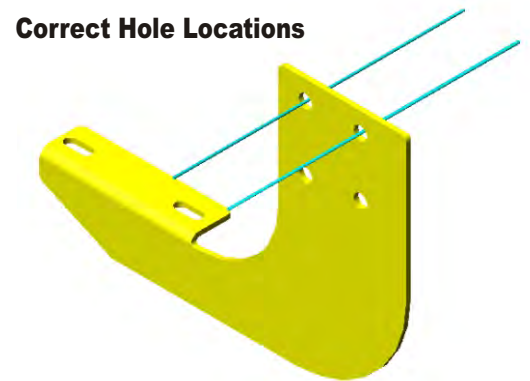
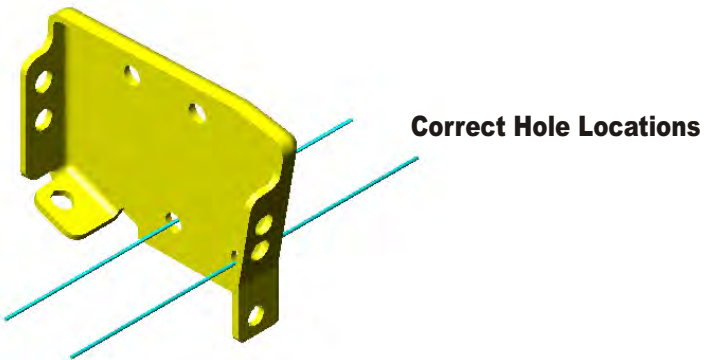
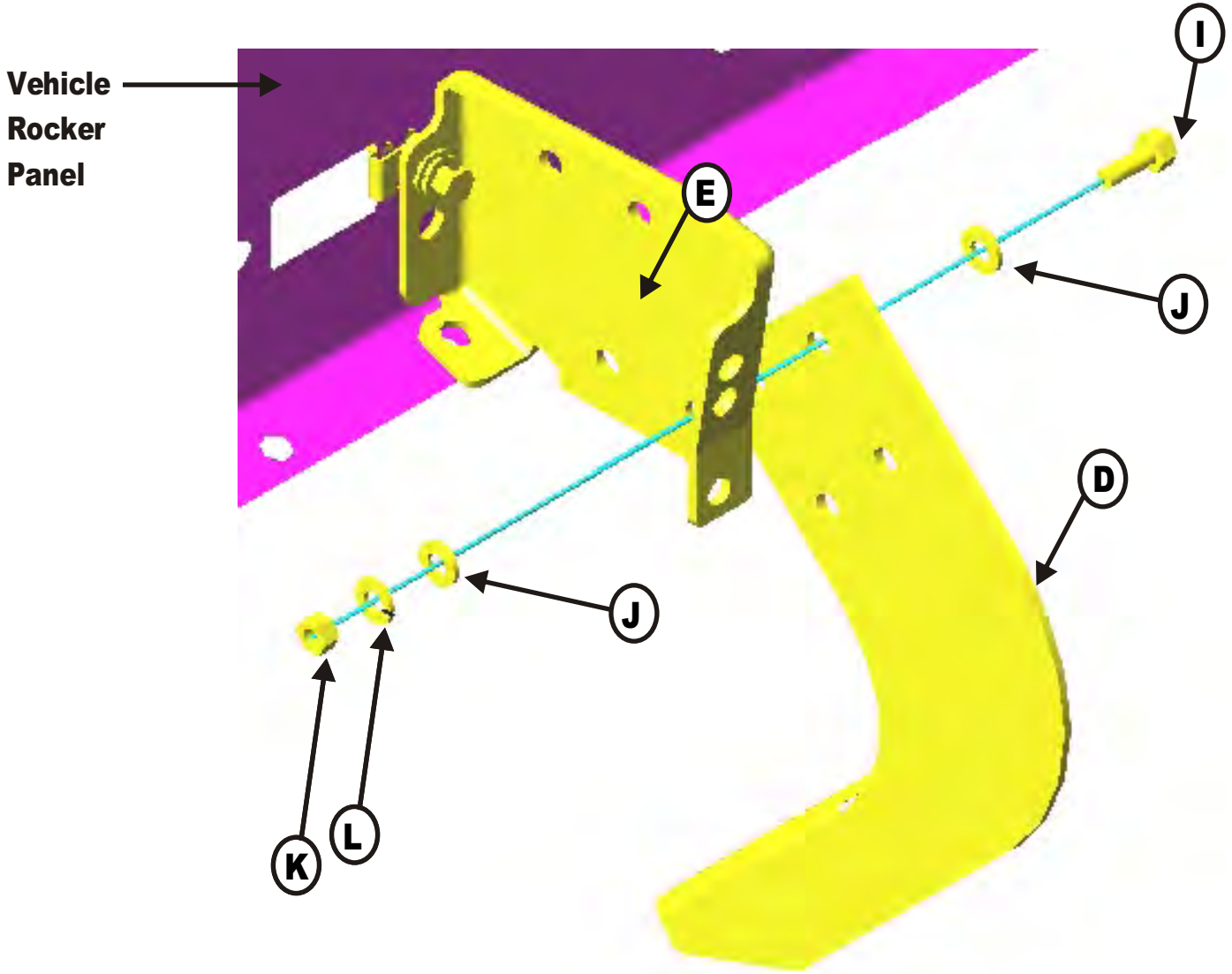

7

Rotate the running board bracket (D) to the upright position and secure it into place using a 3/8 x 1" hex head bolt (I), 3/8" lock washer (L), 3/8" flat washers (J), and 3/8" hex nuts (K) as shown below.

Rote el soporte corriente del tablero (d) a la posición vertical y asegúrelo en lugar usando un perno de la cabeza de la tuerca hexagonal de 3/8 del x 1"(i), la arandela de cerradura del 3/8" (l), las arandelas planas del 3/8"(j), y las tuercas de tuerca hexagonal del 3/8" (k) según lo demostrado abajo.

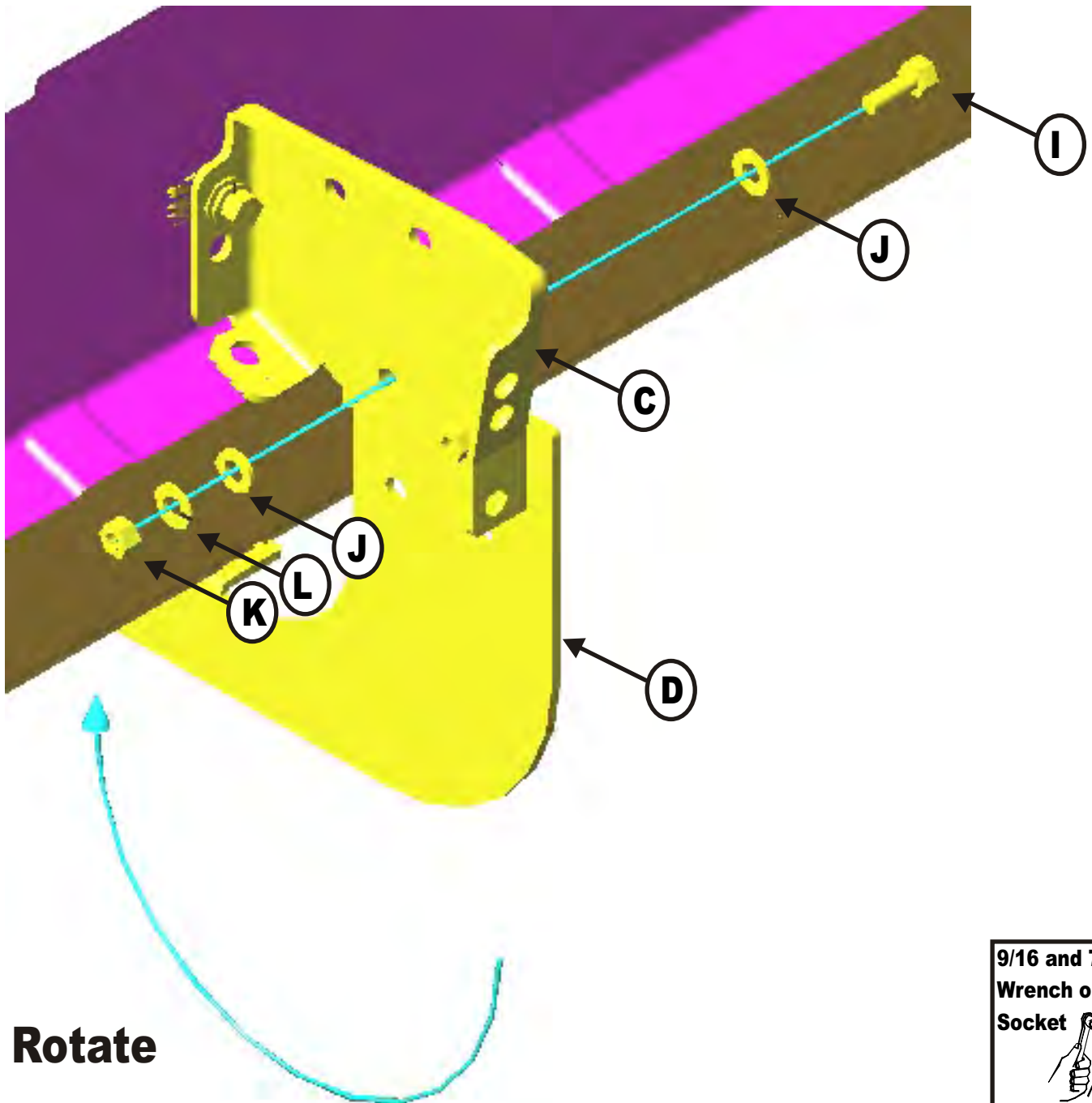

8

Place britetread running board (A) up to the running board brackets (D) as shown below. Slide the britetread running board up to the rocker panel so that it is flush with the vehicle rocker panel.

Placez le panneau courant de britetread (a) jusqu'aux parenthèses de panneau de fonctionnement (d) comme montré ci-dessous. Glissez le panneau courant de britetread jusqu'au panneau de culbuteur de sorte qu'il soit affleurant du panneau de culbuteur de véhicule.

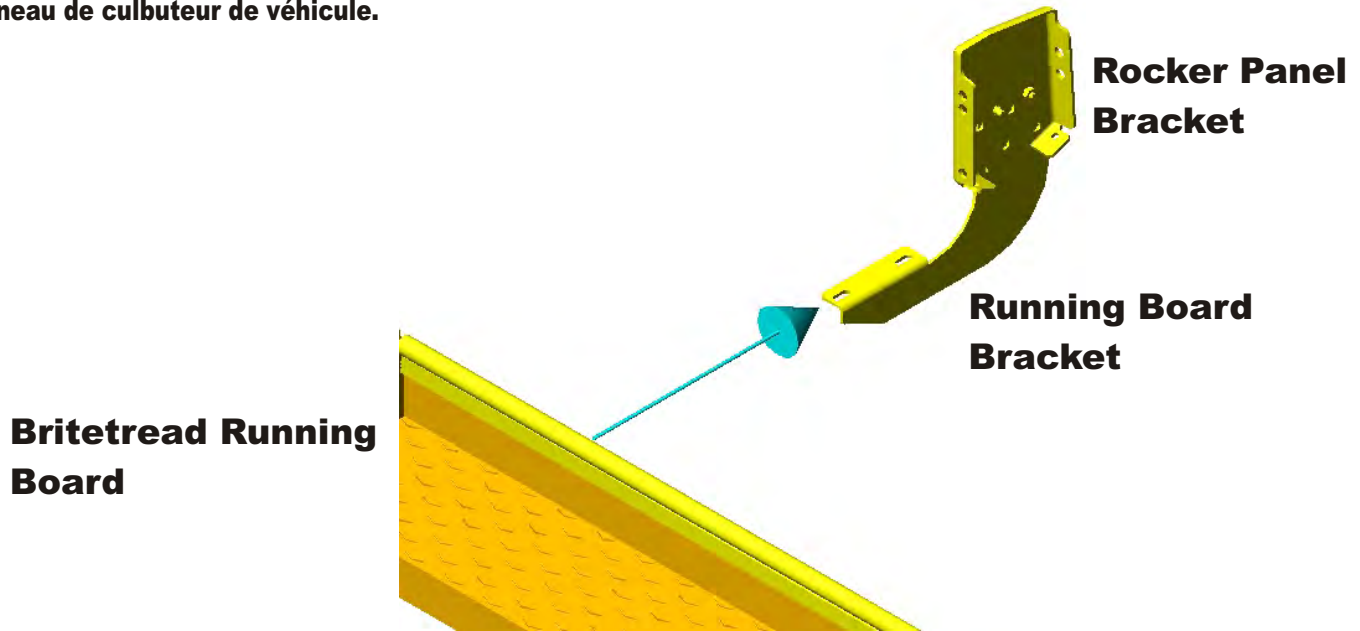

Side View of rocker panel bracket and britetread running board assembly.

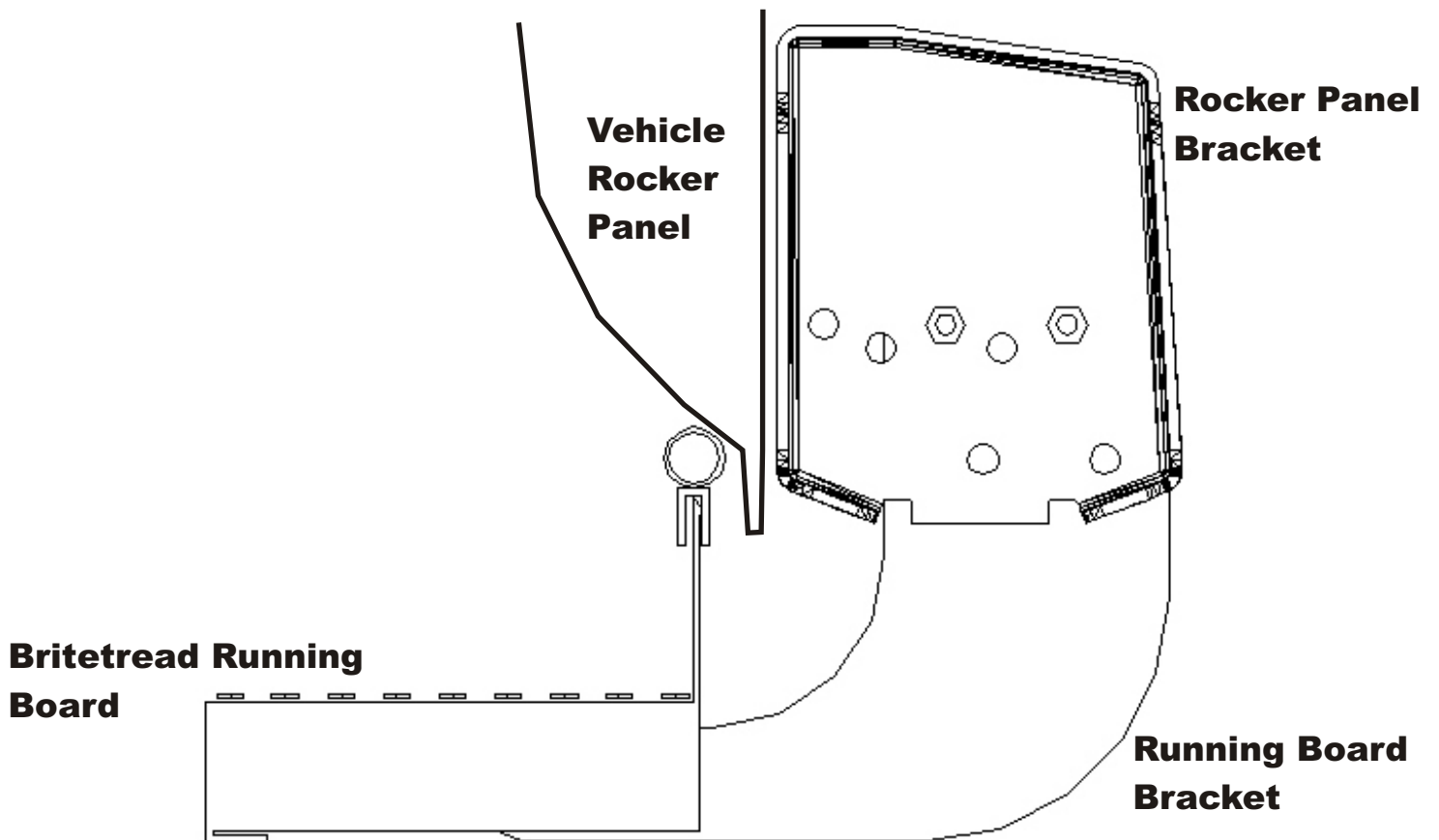

9

Using the bottom holes in the running board bracket (D) as a guide, drill 1/4" holes through the britetread running board. Secure the running board bracket (D) to the britetread running board using 1/4 x 1" ribneck carriage head bolts (H), 1/4" flat washers (F), and 1/4" hex nuts (G). Tighten into place using a 7/16" wrench / or socket.

En utilisant les trous de bas dans le panneau courant encadrez (d) comme guide, forent des trous de 1/4" par le panneau courant de britetread. Fixez la parenthèse courante de panneau (d) au panneau courant de britetread en utilisant les boulons de tête de chariot de ribneck de 1/4 x de 1"(h), les rondelles de 1/4" (f), et les écrous 1/4"d'hexa plats (g). Serrez dans l'endroit à l'aide d'une clé de 7/16"/ou du plot.

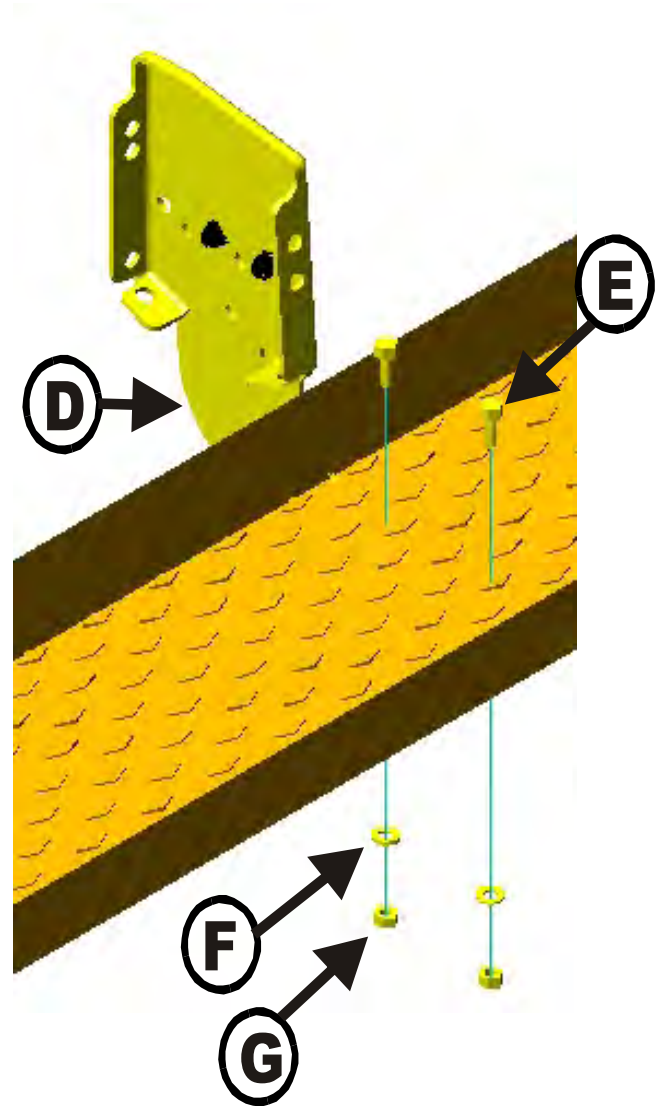
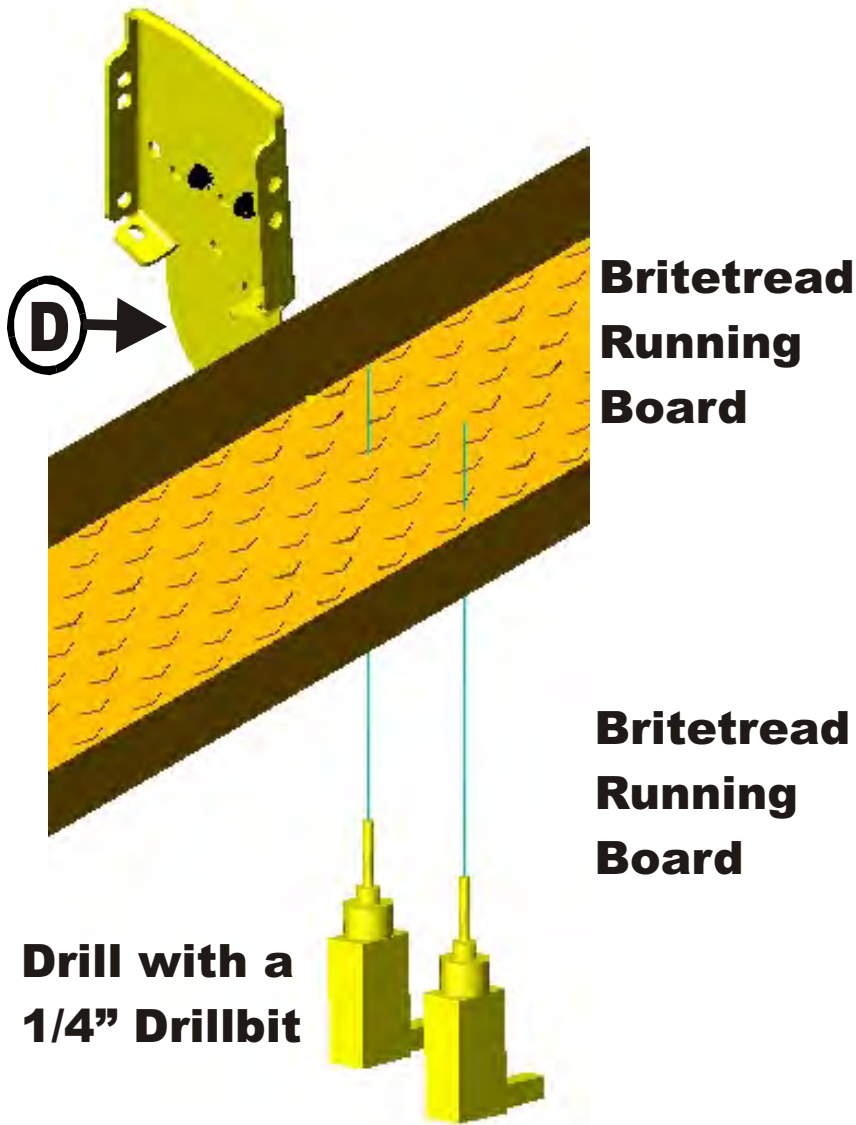
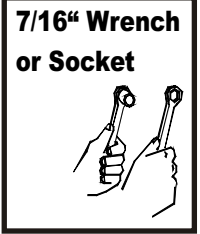
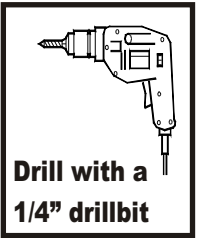

10

Drill two holes through the britetread mudflap and the sheet metal of the vehicle wheel well opening. Secure the britetread mudflap to the vehicle wheel well opening using 1/4 x 1" sheet metal screws (M). Tighten into place using a 3/8" wrench / or socket.

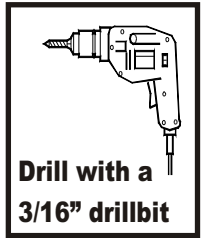

Forez deux trous par le mudflap de britetread et le métal de feuille de l'ouverture de soute de train de véhicule. Fixez le mudflap de britetread à l'ouverture de soute de train de véhicule à l'aide des vis en métal de feuille de 1/4 x de 1"(mj). Serrez dans l'endroit à l'aide d'une clé de 3/8"/ou du plot.

