

Tough Step Installation Instructions

DZ 23

Ford Pickup

Congratulations on your purchase of a quality Dee Zee product. Dee Zee is recognized as having the highest quality running boards and accessories on the market today. We have earned this reputation by offering our customers a product they can be proud to place on their vehicles. Dee Zee meets all the criteria of manufacturing a custom-fit product which guarantees it to be the easiest product to install.

TOOLS REQUIRED:

- A Drill with a set of Bits
- A Tape Measure
- Two 9/16" Wrenches
- A Punch
- Locking Pliers
- A Level
- C-Clamps

PARTS LIST:

	QTY
Tough Steps	2
Aluminum Flat Braces	4
C-Shaped Mounting Bracket.....	2
C-Shaped Welded Mounting Bracket	2
Drivers Side Rear Flat Mounting Bracket	1
Passenger Side Rear Flat Mounting Bracket	1
Spacers	4
Hardware Bag	1

INSTRUCTIONS: Please take time to read all instructions carefully before beginning installation.

STEP 1

Attach an aluminum flat brace to the front and rear of each step with two 3/8" x 1 1/2 carriage bolts (C), flat washers (D), lock washers (E) and nuts (N) in the provided holes. Attach each of the mounting brackets for both sides of the vehicle to the respective locations at the ends of the aluminum flat braces with two 1/4" x 1 1/4" hex head bolts (J), washers (D), lock washers (E) and nuts (N) in the slotted holes. **NOTE:** Refer to the drawing for the proper placement of the brackets, flat washers and lock washer during installation. All mounting brackets should be attached to the inner faces of the flat bar braces. **NOTICE:** On some model vehicles it may be necessary to switch the rear mounting brackets on the driver and passenger side in order to clear an obstruction on the driver side frame. Assemble both sides of the step and position to frame to check each side before proceeding with installation.

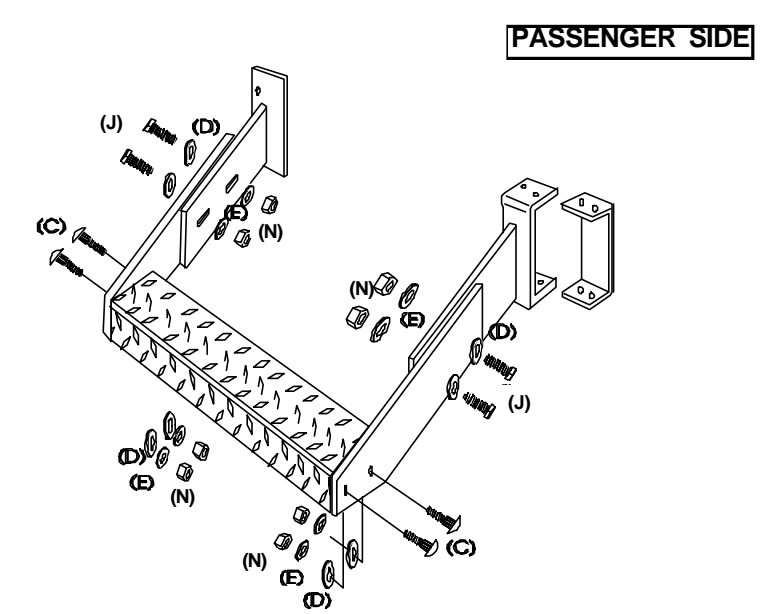
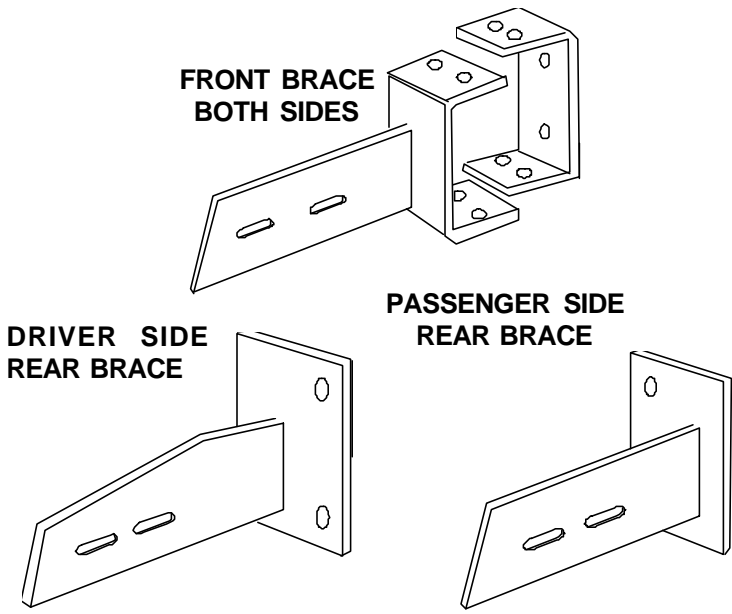
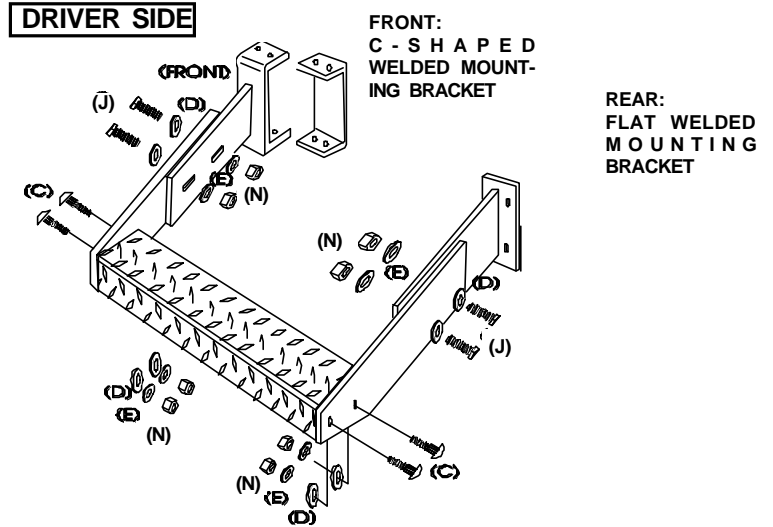

STEP 2

Position the assembled step to the appropriate side on the vehicle so that the mounting brackets are flush to the frame. **NOTE:** On the driver side of the vehicle the parking brake cable runs parallel to the frame. It will be necessary to loosely assemble the two halves of the C-shaped mounting bracket around the emergency brake cable with four 1/4" x 1 1/4" hex head bolts (J), washers (D) and nuts (N). **NOTICE:** On the passenger side of the vehicle, a line runs along the bottom, outside edge of the frame. This line may prevent the mounting brackets from being positioned flush to the frame. If this problem occurs with the vehicle, position spacers between the frame and the bracket. Use the slotted openings in the rear mounting bracket and flat bar brace to offset the width of the spacer.

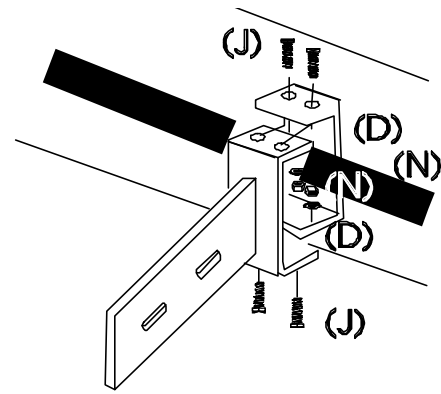

STEP 3

Measure the distance between the bottom of the vehicle rocker panel and the top of the aluminum flat bars. There should be a minimum of 1" clearance between the bottom of the rocker panel and the top of the flat bars and the distance should be the same for both the front and rear flat bars. Adjust the bracing as necessary.

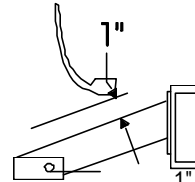

1" CLEARANCE BETWEEN THE FLAT BARS AND THE ROCKER PANEL OF THE VEHICLE.

STEP 4

CAUTION: Before drilling, check the inside to the frame for obstructions (lines, wires, etc.) that may interfere with mounting and drill accordingly.

(#1) On the driver side, hold the step assembly up to the vehicles frame, checking the step to make sure that it is square and level with the vehicle and in the position that you prefer. On the passenger side, feed the C-bracket under the fuel vapor line at the desired location, as shown in the drawing below.

(#2) Use a pencil or marker and trace the holes that are in both the brackets onto the vehicles frame. (Helpful hint for the driver side and passenger side FRONT C-bracket: Use a pair of locking pliers to clamp the bracket to the frame. Disassemble the two C-brackets from each other before marking the frame. After marking the frame, fasten the two C-brackets back together.)

DRIVER SIDE

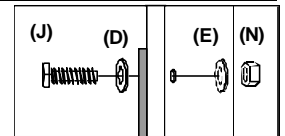
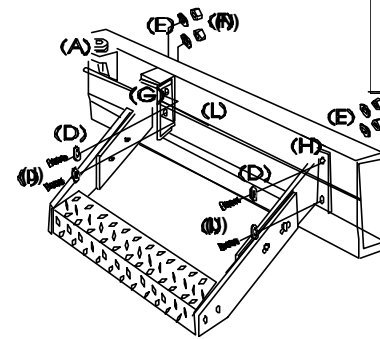

(PICTURE B)

BE SURE THE BRACKETS ARE LEVEL

PASSENGER SIDE

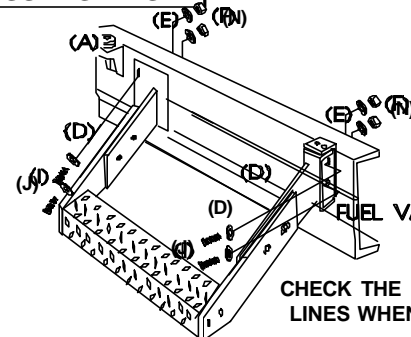

CHECK THE FRAME FOR LINES WHEN DRILLING

PASSENGER SIDE

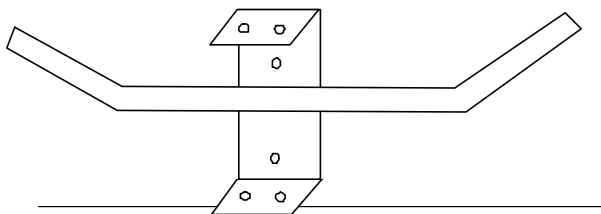

(#3) After marking the frame, move the step assembly out of the way and drill 3/8" holes at each of the marks on the frame.

(#4) Place the step assembly back in place on the vehicle's frame and bolt in place using a 3/8" x 1 1/4" hex head bolt (J) with a flat washer (D), lock washer (E) and nut (N) per hole. {Refer to PICTURE B in the drawing to the above right for the proper placement of the flat washer and the lock washer on the hex head bolt.} Tighten all connections completely.

CLEANING INSTRUCTIONS: To maintain the bright finish of your Dee Zee aluminum steps, clean with a mild detergent.

WARNING: It is unlawful and dangerous to ride on running boards or side box boards while vehicle is in motion. It is the sole responsibility of the owner to check for tire clearance.

***If you should incur any problems with the installation of this product, please feel free to call us at 1-800-779-8222. So that we may better serve you when you call, please have the W/O#, SEQUENCE#, and the DATE from the labels on the outside of the box.*